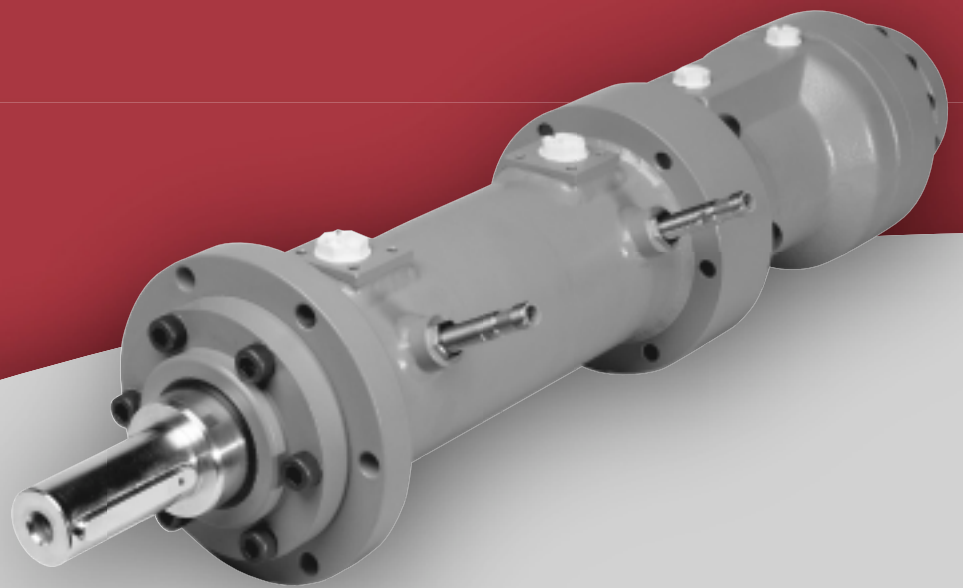




HYDRAULIK
PNEUMATIK



Rotary-linear actuator HSE4

Hydraulic / 100 bar

[GATEWAY
to new technologies.]

highly perfected end cushioning for absorption of kinetic energy

- negating the need for expensive proportional or servo controls with virtually identical characteristics

modern sealing technology

- extended service life of seals
- increased safety, also with regard to the environment
- suitable for most fluids
- all o-rings featuring anti-extrusion back-up rings
- no internal leakages through solid seals enabling the load to be held in any intermediate position

flexible mounting possibilities

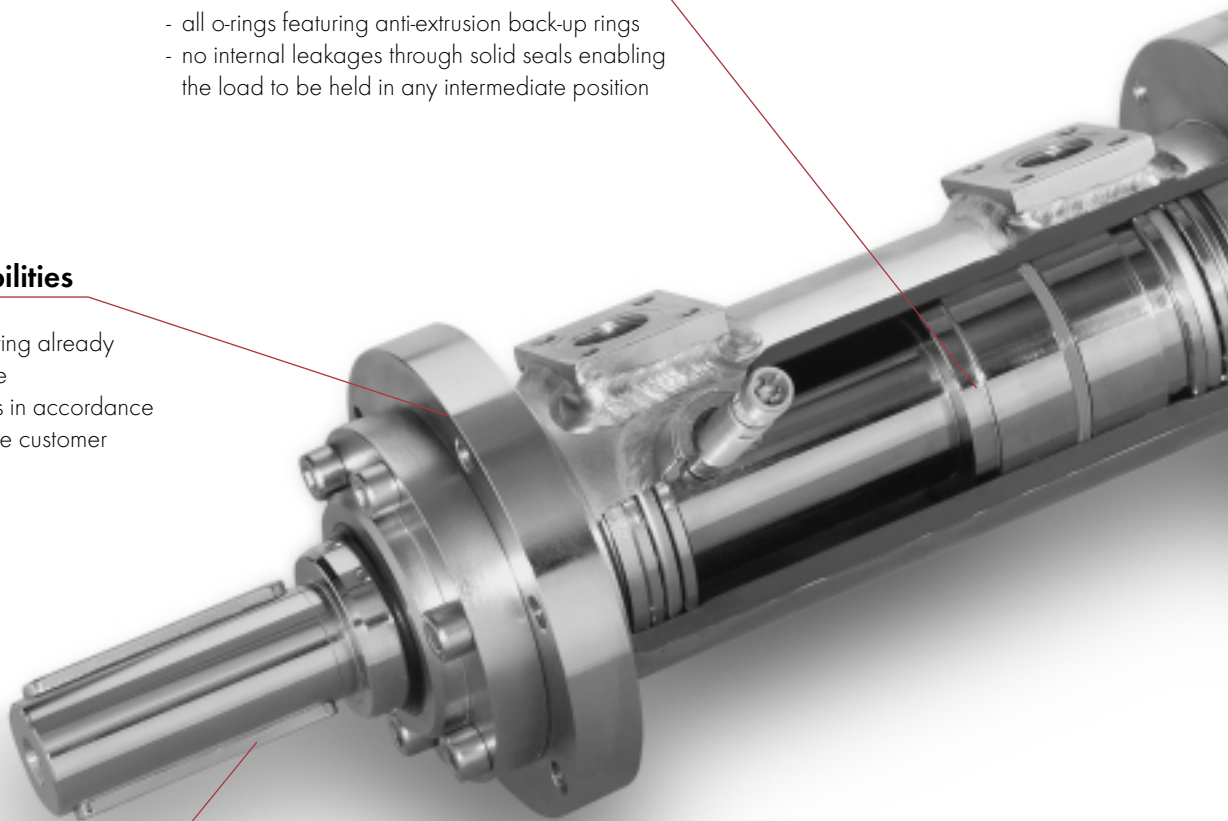
- flange- or foot mounting already in the standard range
- mounting possibilities in accordance with the request of the customer

adjustable drive shaft datum

- if you manufacture the hub, it is not necessary to regard the exact position of the keyways.
- the total angle can be re-adjusted at any time

from 15 bar economically applicable

- through precise combined helical gears and low friction seals, is the HSE4 already from 20 bar economically applicable
- from 10 bar functionally



... over time

- short delivery times through flexible storage
- individual solutions for your product
- quality assurance according to DIN EN ISO 9001:2000

externally adjustable end stop (standard)

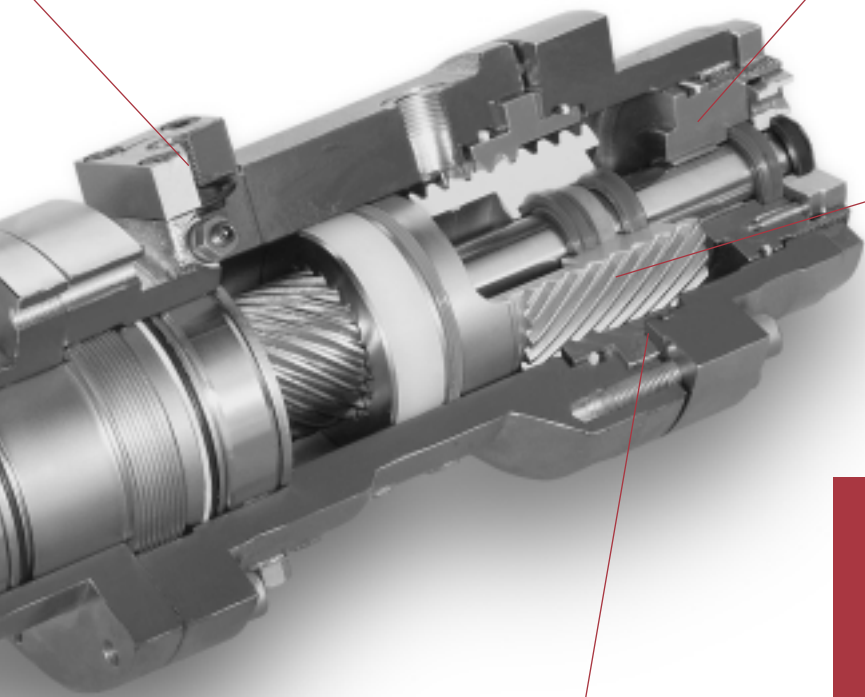
- the end angle can be re-adjusted at any time by $\pm 5^\circ$
- in conjunction with the adjustable drive shaft datum, it is therefore possible to adjust the initial and final position of the total angle required

wear-resistant moving parts

- long service life of the HSE4 through extended-period nitriding
- excellent sliding characteristics of the gears

large-area press-fit joint

- assuring positive power/torque transmission even at peak load conditions



Contents

Features HSE4	2, 3
Function and features	4, 5
End cushioning	6
Options	7
Important technical information	8
Technical data and information	9
Dimensions	10, 11
Applications	12

HSE4

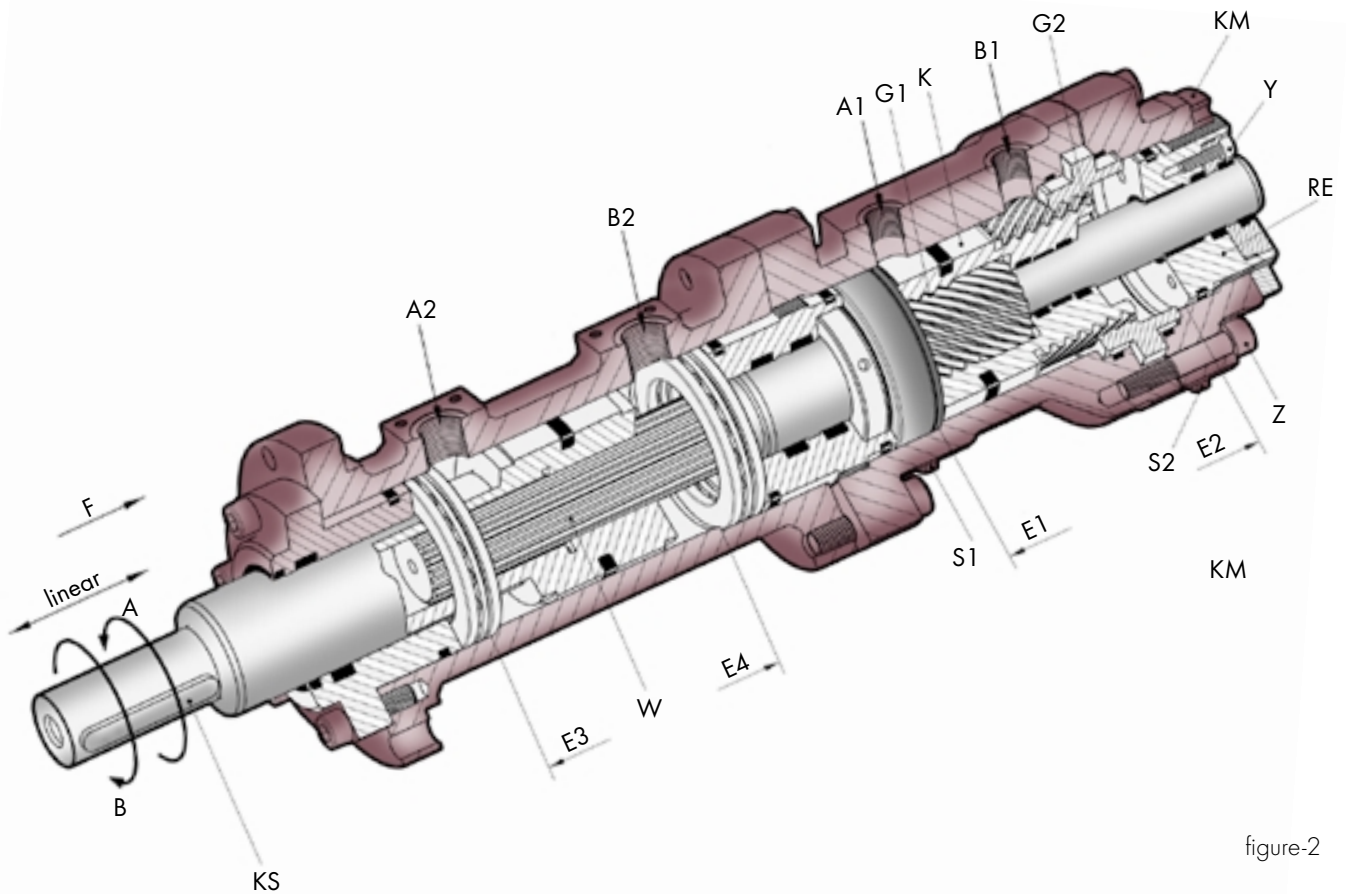


figure-2

[Operation]

The Eckart rotary-linear actuator HSE4 is a combination of a rotary actuator and a double-acting linear cylinder.

rotation movement:

The piston K of the rotary actuator (fig.-2) moves linear by a hydraulic force between the two mechanical end stops E1 and E2. This linear movement will be changed due to the thread G1 and G2 in a rotating movement and this will be transmitted to the shaft W. The shaft W of the rotary actuator grips by form-fit joint into the rod KS of the linear cylinder and transmits the torque over the complete stroke.

The threads of the gear parts are not self-dragging.

stroke movement:

Pressure through the gear parts A2 or B2 causes movement of the rod.

The movements can be controlled separately and together, too.

Because of the permanent lubrication and the nitrated surfaces a high life-time secured.

[Operating pressure]

The maximum operating pressure of the HSE4 is 100 bar. Low friction seals allow the rotary-linear actuator HSE4 to operate from as low as 10 bar operating pressure and so can be economically set at approximately 20 bar.

For especially slow rotation stick-slip seals can be supplied as a special specification.

[Drive shaft datum]

The drive shaft datum can be adjusted within the angular minute range. After loosening the screws Z (1/2 turn), any drive shaft of the piston rod KS can be adjusted. Once the required adjustment has been made, tighten the screws Z again as instructed (see manual).

The drive shaft datum is adjusted at the factory as shown in fig.- 2, with the piston K resting against the stop E1 (also see pages 10 and 11).

[Torque output]

The stated torque figures are effective torques, with the pressure versus the torque curve being virtually linear. For multi-shift, heavy duty or high frequency applications a safety factor between 1.2 and 1.5 is recommended. Torque output is equal in both directions.

[Shaft rotation]

From view F, the piston rod KS will rotate anti-clockwise (arrow A) when pressure is applied to port A1. A different direction of rotation is available as a special feature.

[Rotation]

Standard rotations are 90°, 180°, 270° and 360°. Other rotations can be supplied on request by using the model with the next standard rotation up and limiting the stroke of the piston in accordance. Also available are special models with rotations in excess of 360°.

[Backlash]

In order to function, the set of helical gears and the drive shaft W with the piston rod KS require a certain backlash of approx. 1 degree. On special request, the HSE4 can also be supplied with a reduced backlash.

[Externally adjustable end stop]

This standard feature allows re-adjustment of the angle of rotation as supplied within $\pm 5^\circ$. Adjustment is only possible in the unpressurised state and at the end position E2 (see page 8).

[Fluids]

We recommend mineral oil based hydraulic fluids of the group HLP as per DIN 51524 / Part 2 and VDMA recommendation 24318. Fluids without emulsifying agents reduce the service life of the HSE4. For heavily flammable fluids, please consult factory. The recommended viscosity range is 16 cSt to 68 cSt at 40° to 60° C.

[Operating temperature]

The operating temperature can range from -25° C to +70° C, providing suitable fluids with the correct viscosity rating are used. Please contact us for any applications outside these limits.

[Oil change]

The oil change depends on the size of the system and should be carried out at regular intervals.

[Filtration]

The hydraulic fluid used in the rotary-linear actuator does not exceed the pollution classification 19/15 in accordance with ISO 4406. Therefore, a filter setting of $< 25 \mu\text{m}$ should be installed in the pressure line. With hermetically sealed containers a return filter should suffice. At open containers a pressure filter must be installed in the pressure line. The maintenance intervals described above should be adhered to in line with manufacturer specifications.

[Leakage]

The use of solid seals reduces leakage to the absolute minimum, therefore allowing the load to be held in any intermediate position.

[End of stroke]

The piston K (fig.-2) can be moved under load against the end stops E1 and E2 and be loaded in this position.

The end stops are designed to withstand the force created by the maximum allowable operating pressure relating to the maximum permissible torque output.

If higher forces can be expected, we recommend installation of external stops or other methods of control such as end cushioning (see page 6 and 8) or control valves.

[Installation, maintenance and running in]

An operating instruction for the installation, maintenance and running in is provided with every delivery.

Spare-part-list as well as dismantling and assembly instruction are available by request.

[Non-standard options]

In addition to the options listed in this catalogue, special features can also be supplied, at example profiled shaft-ends, special seals, higher torques or push/pull forces and so on. Please contact our engineers for further information.

[Z1/Z1C - End cushioning]

End cushioning is aimed at dissipating and/or decelerating the rotary movement before the final end stop.

Eckart end cushioning is designed to meet the toughest requirements in modern hydraulics. On the basis of continuous research and development as well as close co-operation with our customers, we can offer you state-of-the-art end cushioning.

- You do not need to include any expensive proportional or servo controls in order to dissipate kinetic energy, because Eckart end cushioning will perform this function almost identically.
- Eckart end cushioning largely prevents pressure peaks, which often destroy actuators with conventional single-stage cushioning or throttle regulation (see diagram in fig.-3)
- The standard effective cushioning range in the end position is approx. 10° for all sizes. Other cushioning can be supplied on request.

[Operation]

The picture shows the cushioning of the rotary actuator.
The function of the cylinder is the same principle.

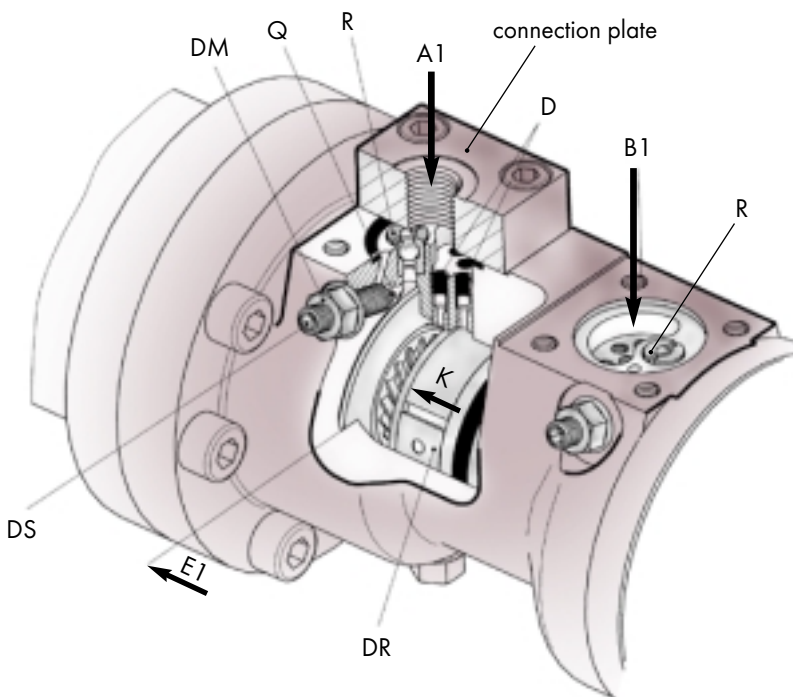


Bild-4

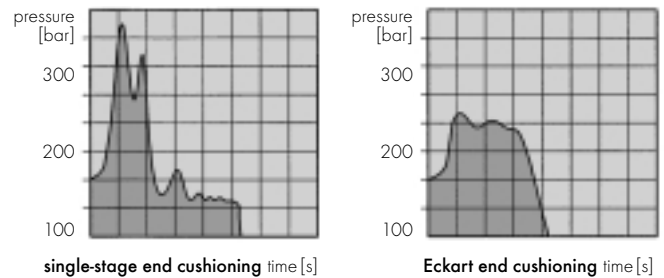


figure-3

The diagram shows one of the advantages of Eckart end cushioning over conventional cushioning with single-stage control

- It is possible for the customer to adjust the cushioning effect individually by screwing in nozzles.
- End cushioning Z1 can also be delivered for each special angle of rotation (see page 8, too).
- End cushioning Z1C can be delivered for the cylinder as well individual for the rod-side or actuator-side, as also for both sides.

A. Starting position

- piston K is in end position E2 (see page 6)
- port A1 is pressurised
- port B1 is unpressurised

B. Reversing the directional control valve

- port B1 is pressurised
- ball check valve R in port B1 opens
- hydraulic fluid flows freely into the cylinder space
- piston K moves in the direction end position E1 (direction arrow piston K)
- ball check valve R is closed in port A1
- pressure medium flows off freely through the bores D

C. Cushioning process

- piston K now approaches the end position E1 and seals the bores D one after the other
- piston speed is progressively reduced
- piston K now completely covers the bores D
- pressure medium can now only escape through the bore Q with the adjusting screw DS to the port A1
- the cushioning effect can therefore be adjusted again by the adjusting screw DS
- the cushioning phase is linear

[FU - Foot mounted model]

Apart from our standard version with flange-mounting, you have also the option of version with foot-mounting.

[SZ - Locating pin]

The locating pin SZ is intended for the fitting of cams Z5 or other control equipment. It simply screws or is glued into the tapping provided at the back end of the shaft. It can be supplied at a later stage without reconstruction of the rotary actuator. The locating pin should not be used for torque transmission or for limiting the angle of rotation.

[Z5 - Cam]

The cam Z5 is clamped onto the locating pin SZ and is used to operate the control switches. If two cams are fitted, the second one is reversed and fitted upside down, while both cams remain individually adjustable.

[Z6 - Control switch assembly]

This option allows the respective end positions of the rotation movement to be touchless and electronically confirmed and the intermediate angles to be recalled. The locating pin SZ and the cam Z5 are included in this option.

Technical data Z6 - inductive (figure-5):

control element:	PNP closer M12x1
nominal control interval:	2 mm
operating voltage:	10 ... 30 V DC
current carrying capacity:	200 mA
connection type:	plug
permissible temperature:	-25° ... +70°
system of protection:	IP 67

Plugs are not delivered as standard!

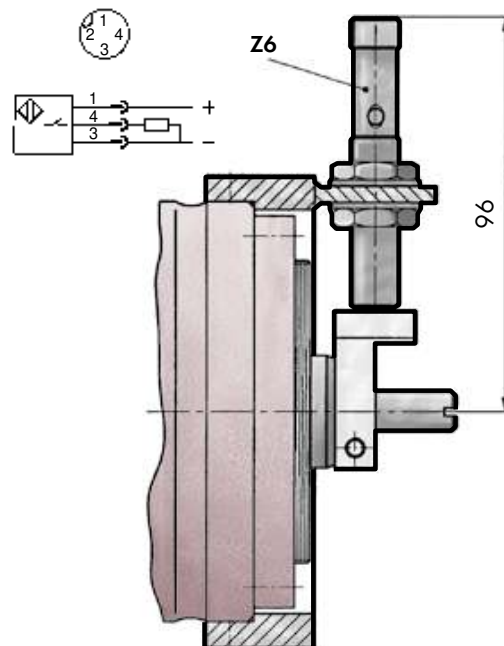
Concerning this we ask for your inquiry.

[Z4 - Long-range adjustable end stop]

The angle of rotation can be adjusted individually with this option, both over its total range of rotation and over a partial range (e.g. total angle 270°, desired partial adjustment of 180° to 270°). To this end, the adjusting insert RE is simply screwed inwards or outwards to give the desired angle of rotation. The shaft goes all the way through, allowing control equipment to be fitted. Adjustment is only possible in the unpressurised state. The total length of the rotary actuator is extended by this option, depending on the range of adjustment.

[Z6C - End position switch]

To check the end positions of the stroke movement, you require an end position switch. The option can be delivered as well individual for the rod-side or actuator-side, as also for both sides.



Because of its torque, angle of rotation, pressure range, positioning accuracy, stability of position, type of attachment and dimensions, the Eckart HSE4 rotary actuator can be used in a wide range of applications.

The selection and the size depends above all on the demands and the operating conditions under which the rotary-linear actuator is operating. For the planning of special

[When planning the rotary-linear actuator, we recommend the following]

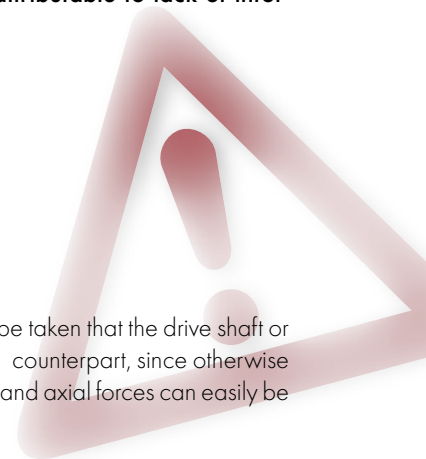
- The mechanical stops within the HSE4 are designed to withstand the force created by the maximum allowable operating pressure relating to the maximum permissible torque output. If they are used to stop the load, the forces acting on them, including forces of inertia, must not exceed the force created by the maximum operating pressure.

If higher forces can be expected, we recommend installation of external stops or other methods of control such as end cushioning, as described below, or control valves.

- On hermetic locking of the rotary actuator (e.g. hydraulically controlled double release valves) and the impact of resetting force on the axle a holding pressure is generated. If the holding pressure reaches the level of the operating pressure there is a torque increase on the axle of 38 %. If resetting forces are expected this should be reflected in selecting the size of the HSE4. This also has to be taken into consideration in those cases of operation in which the optional end cushioning Z1 is used.
- In order to guarantee a fresh supply of pressure fluid or medium, the pressure connection lines should be kept as short as possible, and/or the directional control valve should be mounted directly onto the HSE4. If this is not possible, we recommend a hydraulically controlled double release valve with additional tank line.
- On hermetic locking of the HSE4 (e.g. hydraulically controlled blocking valves) and the impact of heat from external sources it should be considered that the hydraulic pressure in the HSE4 increases by about 6-8 bar per 1°C increase of the temperature. In case of substantial temperature increase the HSE4 could be destroyed. If operating conditions with substantial temperature increases are expected, appropriate protective measures (e.g. safety valves, cycles of operation) should be provided.

items, it is also important for us to be aware of all technical details.

We accept no guarantee claims for disturbances in functioning or complaints which are attributable to lack of information by the customer.



- During installation, care should be taken that the drive shaft or hub is perfectly aligned with the counterpart, since otherwise the maximum permissible radial and axial forces can easily be exceeded.
- In the case of option ZN - gear hub profile DIN 5480, we recommend a calculation of the torsion and fatigue strength of the shaft.
- In case of changing the angle of rotation on actuators with the end cushioning option Z1, the cushioning effect on the bottom side should also be changed.
- Ensure that air bleeding S1/S2 is accessible (important in the case of end cushioning Z1).
- The HSE4 needs to be dismantled when changing replacement parts. It is therefore necessary to allow enough clearance for this to be carried out easily.
- In case of rotary actuators with the end cushioning option Z1, the flowing back of the pressure medium is progressively throttled down which causes the hydraulic pressure to rise on the cushioned side of the piston. In this context it must be ensured that the anticipated cushioning pressure does not exceed the operating pressure maximally admissible. As not all factors can be exactly pre-determined, not all requirement profiles can be implemented in configurations which use the end cushioning Z1. For this reason the details of the execution for the end cushioning Z1 must be established under all circumstances during the commissioning of the initial delivery of the HSE4 (we will be glad to assist you concerning this).

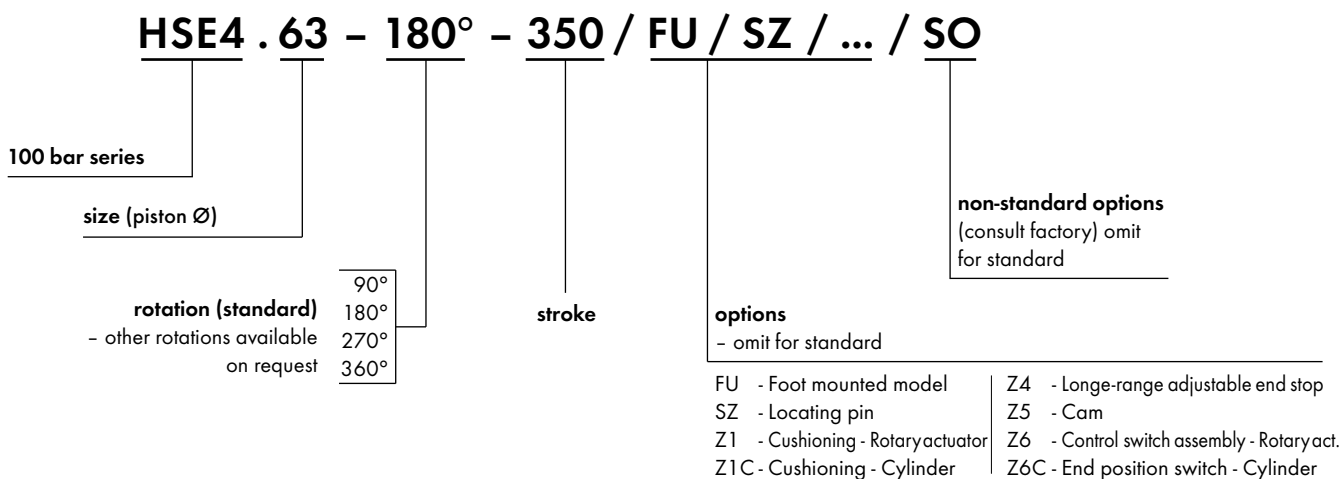
[Technical data]

Size (piston-Ø)		40	50	63	80	100	125	
max. torque at 100 bar	[Nm]	65	135	270	480	1015	2050	
max. push force at 100 bar	[N]	12500	19500	31000	50000	78000	122000	
max. pull force at 100 bar	[N]	7500	10000	15000	26000	40000	72000	
stroke		from 0 to 1200 mm stroke, higher on request						
angle of rotation		standard 90°/180°/270°/360° and any intermediate angle, even above 360°						
medium		recommended: mineral oil of group HLP/DIN 51524, page 2 and VDMA page 24318; others on request						
min. operating pressure required		10 bar						
max. allowable operating pressure		100 bar, higher on request						
installation position		as required, provided that adequate air bleeding is provided						
temperature range		- 25°C bis +70°C / higher or lower on request						
absorption volume rotary actuator	[cm ³ /1°]	0,170	0,352	0,669	1,323	2,624	5,154	
max. time of		0,3 m/s						
weight [kg] at 0 mm stroke (without foot, without cushioning)	angle	90°	9,3	13,9	20,2	36,9	63,5	114,3
		180°	9,8	14,9	21,5	39,4	68,5	124,0
		270°	10,3	15,4	22,8	41,9	73,5	133,5
		360°	10,8	16,5	24,1	44,4	77,5	145,8
+ weight [kg] per 1 mm stroke		0,012	0,017	0,023	0,045	0,062	0,087	
+ weight [kg] FU foot		2,0	2,3	3,8	5,5	8,5	17,1	

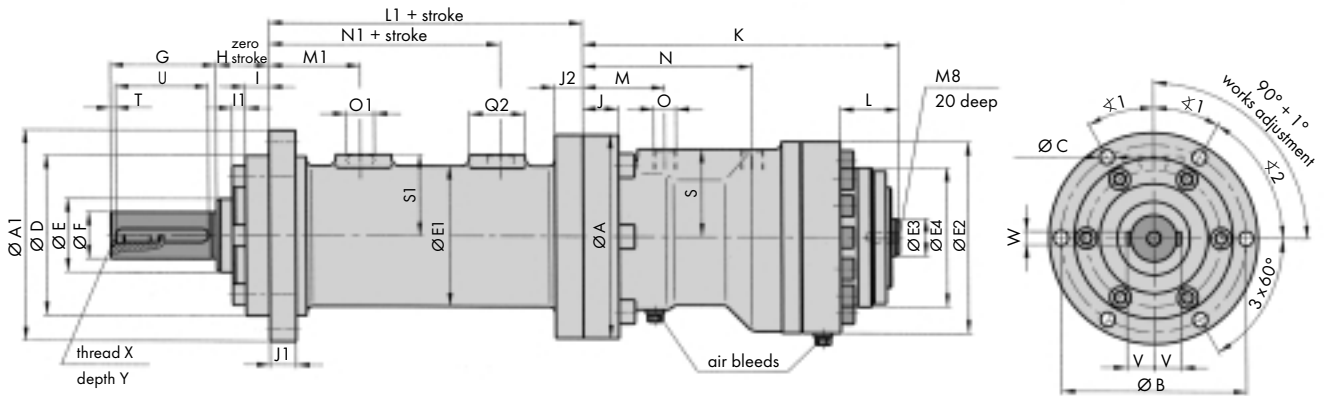
[Important technical information]

- Adherence to the data provided here is a precondition for trouble-free operation.
- The regulations of the Technical Supervision, Social Insurance Against Occupational Hazards and the respective environmental regulations etc. must be observed.
- Plant driven by a rotary actuator must be laid out in such a manner that in case of technical or human failure there is no danger of injury or death.
- We reserve the right to alter or improve design specifications without prior notice.

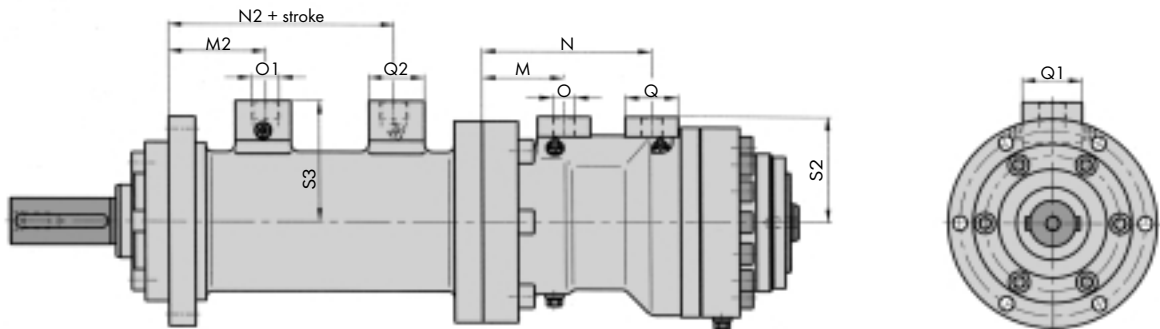
[Ordering code]



[Standard model]



[Model with end cushioning - Z1/Z1C]



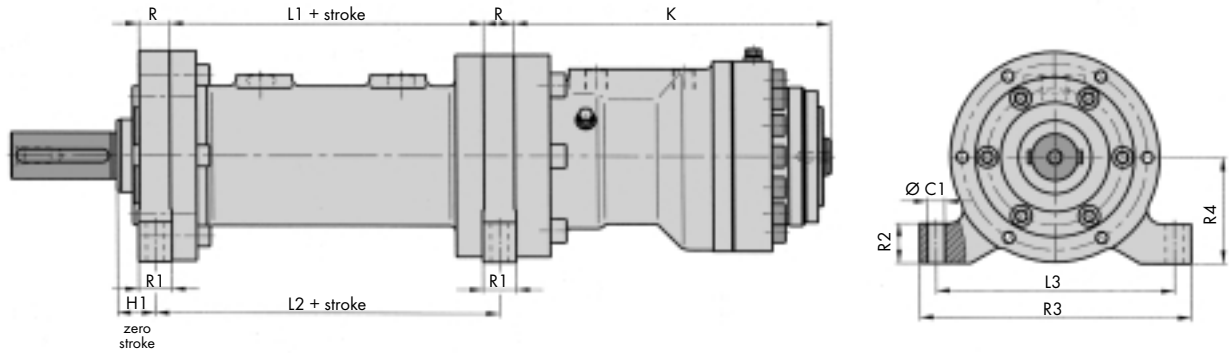
[Comments]

- ¹⁾ Dimension varies for models including option Z4 = adjustment of angle of rotation. Please consult factory.
- We reserve the right to alter or improve design specifications without prior notice.

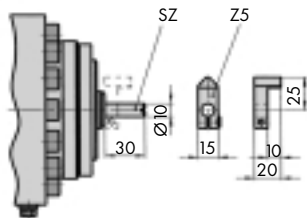
Order code on page 9

Size (piston-Ø)	Rotary-linear actuator HSE4																															
	ØA	ØA1	ØB	ØC	ØC1	ØD	ØE	ØE1	ØE2	ØE3	ØE4	ØF	G	H	H1	I	I1	J	J1	J2	K ¹⁾				L ¹⁾				L1	L2	L3	M
	h7											k6		zero stroke	zero stroke							90°	180°	270°	360°	90°	180°	270°	360°	*stroke	*stroke	
40	98	95	80	8,6	8,6	65	25	55	85	12	58	18	50	33	24	16	7	16	13	14	170	196,8	223,6	250,4	31,5	44,9	58,3	71,7	122	140	110	45,5
50	108	105	90	8,6	8,6	75	35	65	106	16	72	25	60	34	25	17,9	6	18	14	14	181	217	253	289	30,5	48,5	66,5	84,5	137	155	120	50
63	125	125	110	8,6	11	95	45	78	117	22	83	30	80	35	23,5	14,8	8,2	23	19	15	195	239	283	327	31,3	53,3	75,3	97,3	162	185	150	54
80	152	158	140	11	13	120	55	105	143	28	104	35	80	40	28,5	18	10	27	20	21	238,5	292,5	346,5	400,5	44,5	71,5	98,5	125,5	187	210	180	62
100	178	178	160	11	13	140	70	125	170	40	132	45	110	45	31	20	10	31	25	23	280	351,6	423,2	494,8	57	92,8	128,6	164,4	232	260	200	65
125	224	236	210	13	17	180	80	155	216	50	166	60	140	50	34	23	12	35	30	25	328	418	508	598	73	118	163	208	268	300	265	75,5

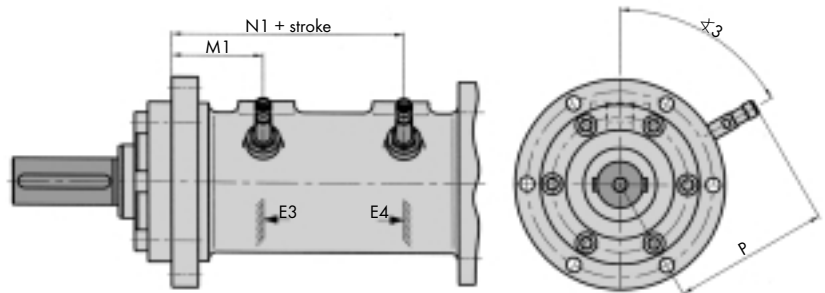
[Foot mounted model - FU]



[Cam - Z5 and locating pin - SZ]

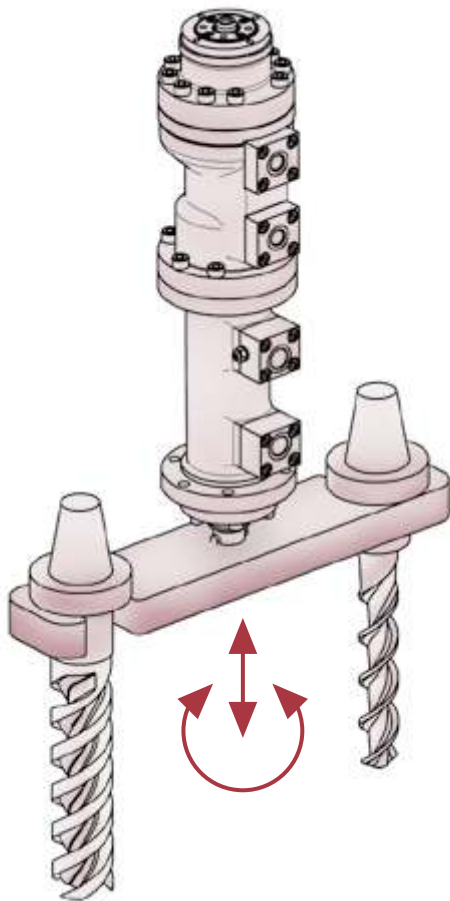


[End position switch - Z6C]

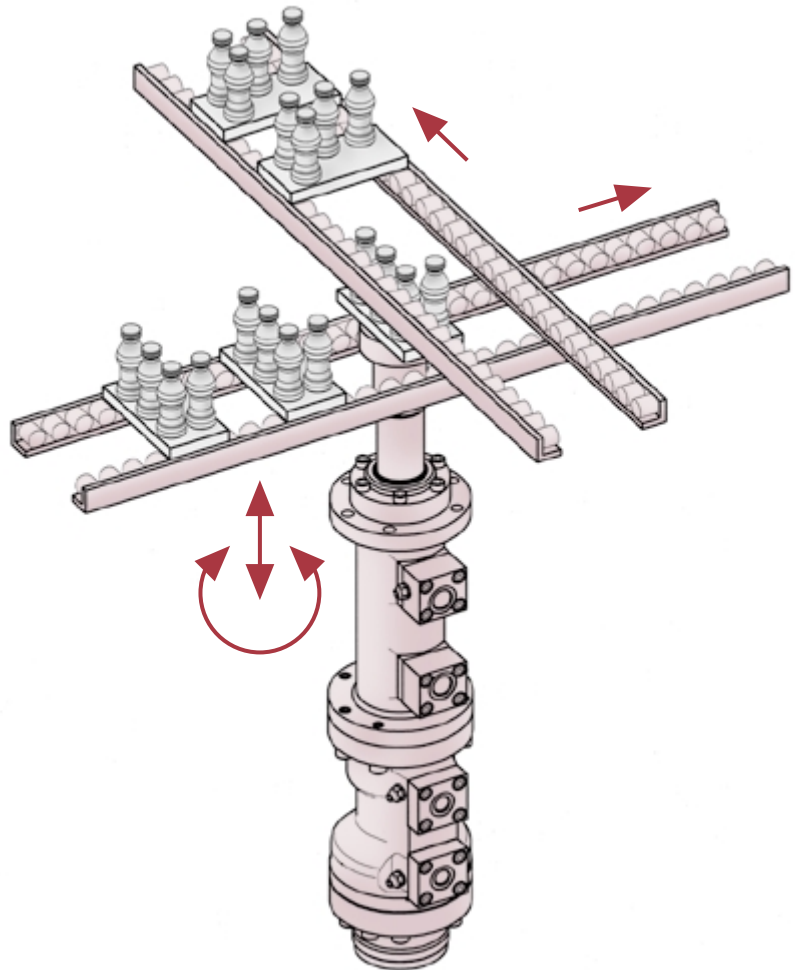


Non-standard options on request

Rotary-linear actuator HSE4																											Size (piston-Ø)					
M1	M2	N				N1	N2	O	O1	P	Q	Q1	Q2	R	R1	R2	R3	R4	S	S1	S2	S3	T	U	V	W		X	Y	>1	>2	>3
		90°	180°	270°	360°	+stroke	+stroke	port size	port size														DIN 6885	DIN 6885								
39	45	89	102,4	115,8	129,2	77	71	G1/4"	G3/8"	98	40	42	37	18	20	20	130	50	41,5	34	55,3	59	1,5	45	11,5	6	M6	16	45	45	120	40
49	56	98	116	134	152	89	82	G1/4"	G3/8"	103	40	42	37	18	20	20	140	55	49	38,5	62,8	63,5	3	50	15,5	8	M8	20	40	50	65	50
57	61,5	107	129	151	173	106	101,5	G3/8"	G1/2"	109,5	40	45	42	23	25	25	175	65	53	46,5	67	76,5	4	70	18	8	M10	25	45	45	67,5	63
69	73,5	128	155	182	209	125	120,5	G3/8"	G1/2"	118	40	45	42	23	25	30	205	80	65,5	61	79,5	91	4	70	20,5	10	M12	30	30	60	60	80
94	98,5	147	182,8	218,6	254,4	155	150,5	G3/8"	G1/2"	128	40	45	42	28	30	30	230	90	80	71	94	101	4	100	26	14	M16	38	30	60	60	100
109	116,5	168	213	258	303	174	166,5	G1/2"	G3/4"	140,5	50	55	55	32	35	40	300	120	102	85,5	121	115,5	4	125	34	18	M20	40	30	60	60	125



tool change



move

distributed by:

© ECKART GmbH 2004



ECKART GmbH

Gewerbegebiet Wallroth
D-36381 Schlüchtern

Telefon +49 (0)6661 9628-0
Telefax +49 (0)6661 9628-50

E-Mail info@eckart-gmbh.de
[http:// www.eckart-gmbh.de](http://www.eckart-gmbh.de)