

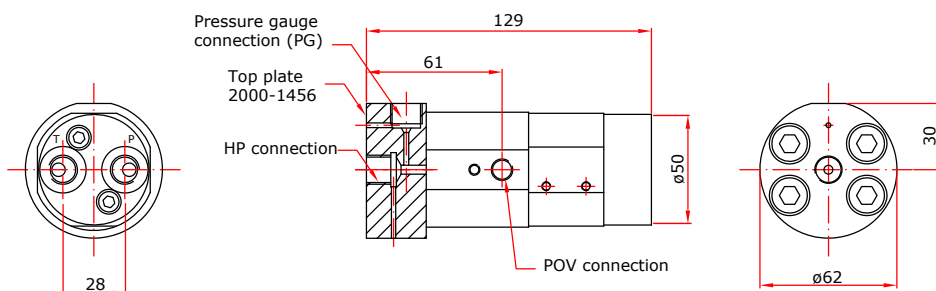

# Operation Instructions for the MP-2000-XP Pressure Intensifier



### Before installing the intensifier

Ensure the surroundings and the connecting parts are clean and free from burrs.

### Fluids

For use with standard hydraulic oils and water glycol (min. 5% glycol). Preferred viscosity range 20 - 46 cSt

### Filtration requirements

10 µm nominal or better, maximum 19/16 according to ISO 4406

### Connecting the intensifier

Connecting the MP-2000-XP pressure intensifier to a system is only to be done by trained personnel.

1. Connect the P-port of the intensifier to the hydraulic pressure supply.
2. Connect the T-port to the tank line.
3. Connect the POV-port to the hydraulic supply line as shown below
4. Connect the HP-port to the end pressure line / cylinder.

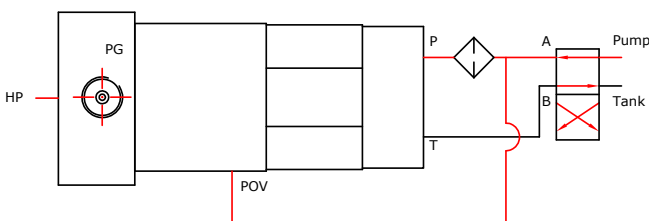

### Port sizes

The P and T ports are G1/4" (1/4" BSPP)  
 The POV connection is G1/8" (1/8" BSPP)  
 The HP connection (outlet pressure) is G1/4" (1/4" BSPP) with 120° cone sealing (see below)  
 The Pressure gauge connection is 9/16"-18 UNF with 60° cone sealing (see below)

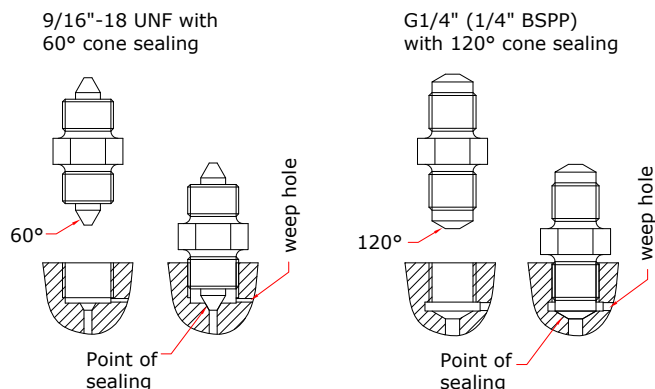

### CAUTION:

Ensure the fittings and components on the output side are rated for the end pressure delivered by the Scanwill intensifier.

### Hydraulic bleeding

During start-up of the system, it is recommended to ensure no air is trapped in the system, as this may cause function problems.

## Function

The MP-2000-XP is an in-line hydraulic pressure intensifier designed to increase a supplied pump pressure to a higher end pressure (for fluids only). The intensification ratio is fixed, and the end pressure is always proportional with the supplied pressure. Fig. 1 shows the schematic of the MP-2000-XP intensifier increasing the pressure in a single or double acting cylinder.

When applying flow to the P-port and connecting the T-port to tank, the full pump flow will go straight through the intensifier check valves CV1, CV2 and POV (optional) to the cylinder, allowing the rod to move out at pump speed. When the cylinder is filled up and the pressure has risen to pump pressure, the intensifier pistons automatically increase the pressure to the set end pressure. Keeping the pump connected ensures the intensifier will automatically work to maintain the end pressure in the cylinder, in case the pressure drops.

The integrated pilot operated check valve POV is activated by changing position on the directional valve positioned before the intensifier. By connecting the T-port to the pump and the P-port to tank, a pilot signal will open the POV, and a free passage from the high pressure side back to tank is created. This will decrease the pressure on the end pressure side, and allow a cylinder piston to retract. The oil from the cylinder is lead out the intensifier on the side port POV, ensuring filtered and cooler oil is used for the next cycle.

Fig.1

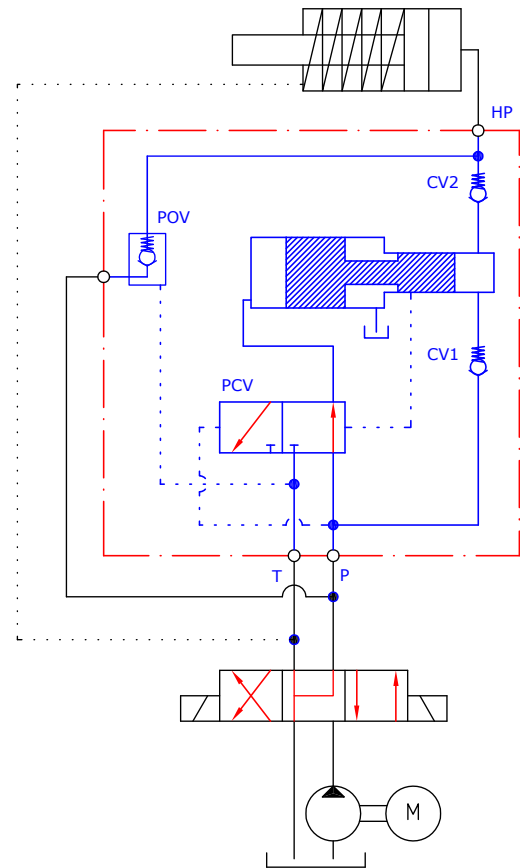

## High Flow Applications

In systems with flow rates larger than permissible for the intensifier, the inlet to the P and T ports must be limited according to the flow-pressure table below. To maintain the speed in the cylinder, an external p.o.check valve capable of handling the system flow and end pressure can be inserted in parallel with the MP-2000-XP hydraulic pressure intensifier

## Intensification ratios, flow and pressure settings

Product number	Intensification ratio	Max. supply Flow* (LPM)	Outlet supply pressure** (bar)	Average outlet Flow*** (LPM)	Outlet pressure range**** (bar)
MP-2000-XP-7.0	7.0	13.0	200	0.2	140 - 1,400
MP-2000-XP-10.0	10.0	12.0	200	0.2	200 - 2,000
MP-2000-XP-13.0	13.0	10.0	200	0.1	260 - 2,600

\* Max. supply flow limits not to be exceeded, as this will damage the internal check valves and over speed the intensifier pistons.  
Min. supply flow is 2 LPM

\*\* Max. supply pressure limits not to be exceeded, as this will cause damage to the intensifier parts, and will cause to high outlet pressure.  
Pressure spikes must be avoided.

\*\*\* The Average flow is the flow generated by the intensifier pistons when increasing the pressure from pump pressure to end pressure. Initially the flow is high, and as the pressure increases the flow decreases and will eventually stop when the end pressure has been reached.

\*\*\*\* The outlet pressure is proportional with the supplied pressure, and can be set at any value within the range.  
The max. pressure within the range for each intensification ratio must not be exceeded

**For additional technical support in North America, please contact your authorized distributor or IC-Fluid Power, Inc. for more information: [sales@icfluid.com](mailto:sales@icfluid.com) or +1.877.423.5843.**