

Operation Instructions for the MPL-4000 Pressure Intensifier

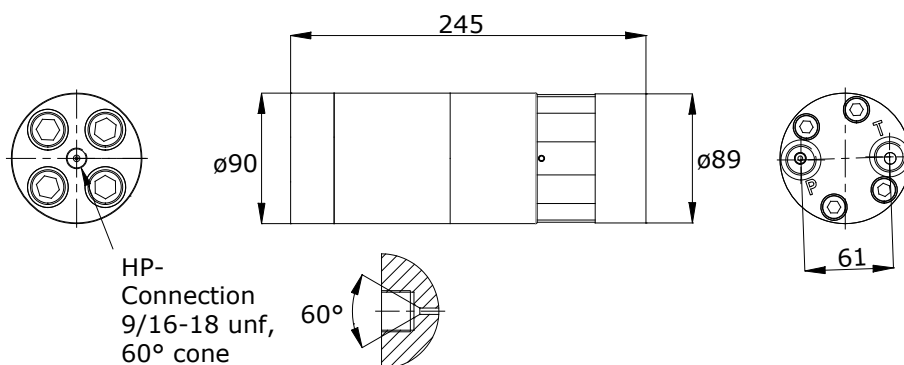

P & T ports: G1/2" (1/2" BSPP)

Before installing the intensifier

Ensure the surroundings and the connecting parts are clean and free from burrs.

Connecting the intensifier

Connecting the MPL-4000 pressure intensifier to a system is only to be done by trained personnel.

1. Connect the P-port of the intensifier to the hydraulic pressure supply.
2. Connect the T-port to the tank line.
3. Connect the HP-port to the end pressure line / cylinder. The connection must be rated for high pressure, and sealing in the bottom of the threaded hole.

Fluids

For use with standard hydraulic oils and water glycol (min. 5% glycol). Preferred viscosity range 20 - 46 cSt

Filtration requirements

10 µm nominal or better, maximum 19/16 according to ISO 4406

Hydraulic bleeding

During start-up of the system, it is recommended to ensure no air is trapped in the system, as this may cause function problems.



CAUTION: Ensure the fittings and components on the output side are rated for min. 4,000 bar.

Mounting and connection

The MPL-4000 pressure intensifier can be mounted using a standard pipe clamp.

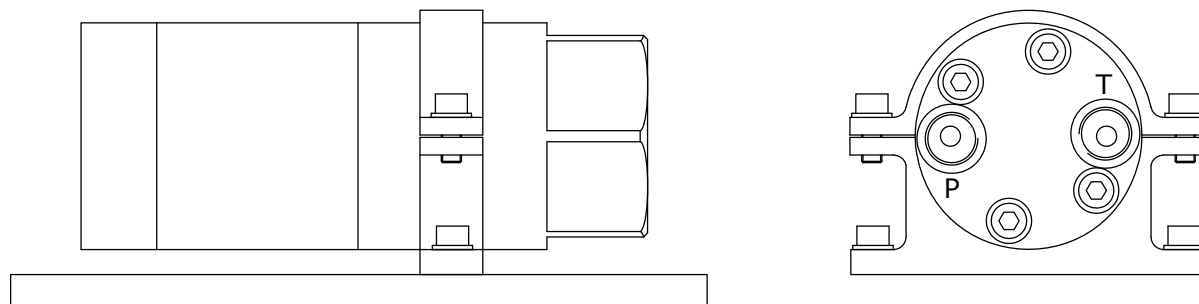

Function

The MPL-4000 is an in-line hydraulic pressure intensifier designed to increase a supplied pump pressure to a higher end pressure (for fluids only). The intensification ratio is fixed, and the end pressure is always proportional with the supplied pressure. Fig. 1 shows the schematic of the intensifier increasing the pressure in a single or double acting cylinder.

When applying flow to the P-port and connecting the T-port to tank, the full pump flow will go straight through the intensifier check valves CV1, CV2 to the cylinder, allowing the rod to move out at pump speed. When the cylinder is filled up and the pressure has risen to pump pressure, the intensifier pistons automatically increase the pressure to the set end pressure. Keeping the pump connected ensures the intensifier will automatically work to maintain the end pressure in the cylinder, in case the pressure drops.

Retracting the cylinder must be done by external valves.

High Flow Applications

In systems with flow rates larger than permissible for the intensifier, the inlet to the P and T ports must be limited according to the flow-pressure table below. To maintain the speed in the cylinder, an external p.o.check valve capable of handling the system flow and end pressure can be inserted in parallel with the MPL-4000 intensifier

Fig.1

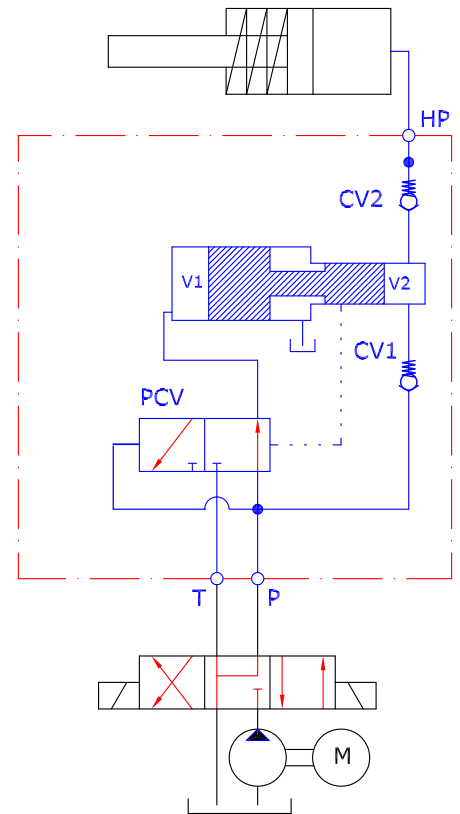

Intensification Ratios, Flow and Pressure settings

Product number	Intensification ratio	Max. supply Flow* (LPM)	Inlet supply pressure** (bar)	Average outlet Flow*** (LPM)	Outlet pressure range**** (bar)
MPL-4000-S-20	20.0	25.0	200	2.5	1,000 - 4,000

* Max. supply flow limits not to be exceeded, as this will damage the internal check valves and over speed the intensifier pistons.
Min. supply flow is 8 LPM

** Max. supply pressure limits not to be exceeded, as this will cause damage to the intensifier parts, and will cause to high outlet pressure.
Pressure spikes must be avoided.

*** The Average flow is the flow generated by the intensifier pistons when increasing the pressure from pump pressure to end pressure. Initially the flow is high, and as the pressure increases the flow decreases and will eventually stop when the end pressure has been reached.

**** The outlet pressure is proportional with the supplied pressure, and can be set at any value within the range. The max. pressure of 4,000 bar must not be exceeded.