

Rotary Joints

Series DC

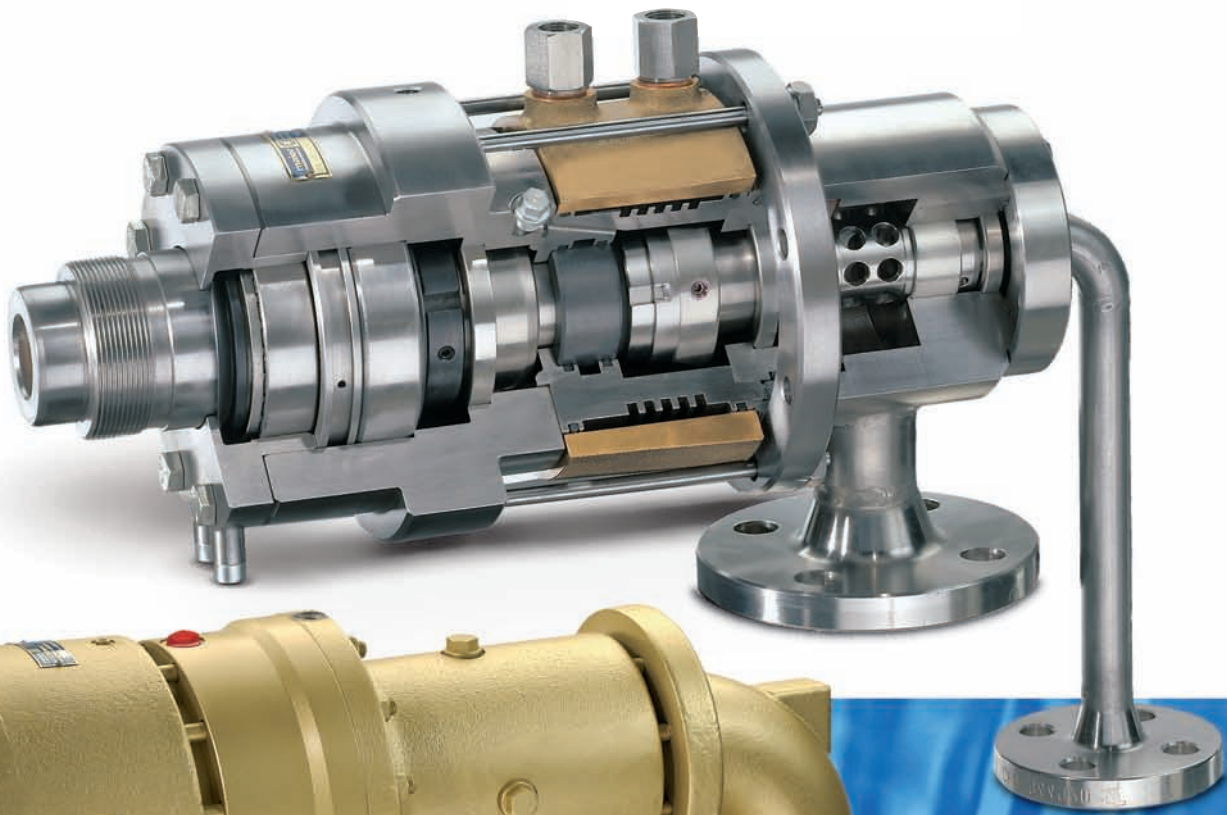

DCL and DC Rotary Joints

DCL and DC rotary joints are suitable for hot water (series DCL up to 180°C, 16 bar and series DC up to 250 °C, 40 bar) and speeds of up to 1200 min⁻¹. Series DC rotary joints are also suitable for steam up to 250 °C, 40 bar. Typical applications include coating and laminating systems, paper, nonwoven and textile calenders as well as dryers.

When these media are sealed, there is the danger of dry run at the seal which reduces reliability and service life. The internationally patented system of series DC successfully prevents this problem (EP 0806578, US 5778971). The temperature in the area of the mechanical seal is reduced by means of cooling water to ensure proper functioning of the units. Flow and temperature sensors monitor operation. Clean, treated and filtered water is required.

Advantages and Features:

- Considerably longer service life as compared to other rotary joints.
- Greater application data range as compared to other rotary joints.
- Longer machine running times, easily forecastable maintenance due to temperature sensor at the mechanical seal. This sensor monitors the function of the mechanical seal in the rotary joint.
- The mechanical seal is pressurized from the outside for superior reliability and low friction torque.
- Usage of cooling water for the integrated cooling system.
- An insulating disk protects the mechanical seal from abrasive pollutants and prevents the dissipation of heat from the heating circuit to the cooled seal area.
- Rigid tapered roller bearings for high speed, pressure and additional loads.
- DCL and DC bearing lubrication with high temperature grease up to 220°C, 25 bar.

- The static support in the rotor of the version with rotating inner pipe (version B2) prevents wear at this point.

Special Advantages and Features of DC:

- Double-walled rotor with air gap protects the bearing and seal area from excessively high temperatures.
- PTFE shaft seal between steam and condensate channel separates the steam from the condensate chamber to assure reliable discharge of condensate.
- The roller bearings are lubricated by means of a recirculating oil system in the range from 220°C-25 bar to 250°C-40 bar.

Technical information:

- Rotor and seal housing made of stainless steel.
- Housing parts made of stainless steel (spheroidal graphite cast iron for DCL DN 80 – DN 125).
- Housing connections at B and C for DCL DN 32 and DN 40 through right-hand thread ISO 228. Other versions with housing connections as per DIN 2635. Flanges according to ANSI are available.
- Housing connections B and C can be turned in increments of 8 x 45° each.
- Connection to rotating pressurized system by means of screw flanges.
- Anti-rotation device can be swiveled in increments of 8 x 45°.
- Cooling water supply connection for DCL at position 180° (for DC at position 0°), cooling water return connection at position 0°, connection with female thread according to ISO 228. The position of the given connections must not be changed.
- Bleed screws for DN 80 – DN 125 in the seal housing 3 x 90° G 1/2.

Application Data

	DCL	DC
Type	1, B2	1, B2
Nominal diameter DN mm	32...150	32...100
Medium	Water	Water, Steam
Temperature min...max °C	-10...180	-10...250*
Pressure PN min...max bar	0,8...16	0,8...40*
Speed max.min ⁻¹	$\frac{1.000.000}{(DN \times PN)}$	$\frac{1.000.000}{(DN \times PN)}$

Speed limitation DN	32	40	50	65	80	100	125	150
Speed max.min ⁻¹	1200	1000	950	800	750	650	550	500

* Values 220° to 250°C and 25 to 40 bar with recirculating oil lubricating system. Avoid operating the unit under conditions involving several maximum values attained at the same time.

Ordering Information

Example:

DC	L	B	2	32	F	-005
----	---	---	---	----	---	------

Series DC	
DC Up to 250°C DCL Up to 180°C ("light version")	
B Version with rotating inner pipe with rotating inner pipe between supply and return	
1 Number of housing connections for Monoflow version 2 Duoflow version	
Nominal diameter DN in mm (corresponds to dimension A) 32, 40, 50, 65, 80, 100, 125, 150	
F Rotor connection for screw flange connection	
Consecutive number assigned by plant.	

When placing the order, please copy this page, fill in the blanks and send it by fax to **+49 7321 317-139**.

Customer

Order number

Assembly by modular system for DCL – DC DN 32-100

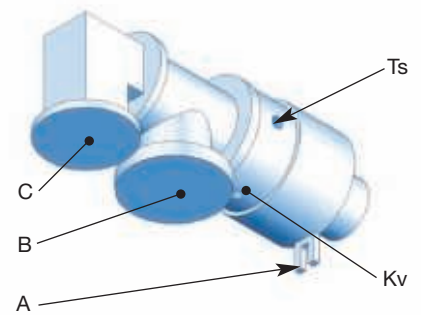
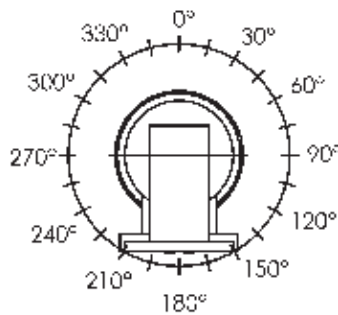
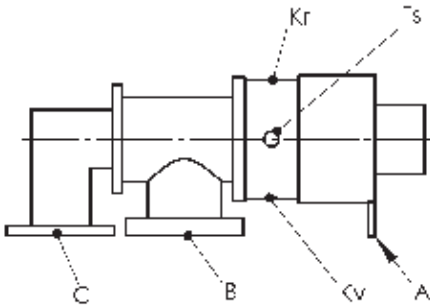

View of the rotary joint as specified (side view from the left). Please tick the individual items.

Your order will be made according to these specifications.

Different items for cooling water supply:

*1 = supply for series DC

*2 = supply for series DCL

Item	Cooling water supply Kv	Cooling water return Kr	Temperature-sensor Ts	Locking A	Connection B	Connection C (if version B2)
0 °	<input checked="" type="checkbox"/> *1	<input checked="" type="checkbox"/>				
15 °						
30 °						
45 °				<input type="checkbox"/>	<input type="checkbox"/>	<input type="checkbox"/>
60 °						
75 °						
90 °			<input type="checkbox"/>			
105 °						
120 °						
135 °				<input type="checkbox"/>	<input type="checkbox"/>	<input type="checkbox"/>
150 °						
165 °						
180 °	<input checked="" type="checkbox"/> *2			<input type="checkbox"/>	<input type="checkbox"/>	<input type="checkbox"/>
195 °						
210 °						
225 °				<input type="checkbox"/>	<input type="checkbox"/>	<input type="checkbox"/>
240 °						
255 °						
270 °			<input type="checkbox"/>			
285 °						
300 °						
315 °				<input type="checkbox"/>	<input type="checkbox"/>	<input type="checkbox"/>
330 °						
345 °						

DCL 1

For the passage of one medium in one direction

DN 32 – 150

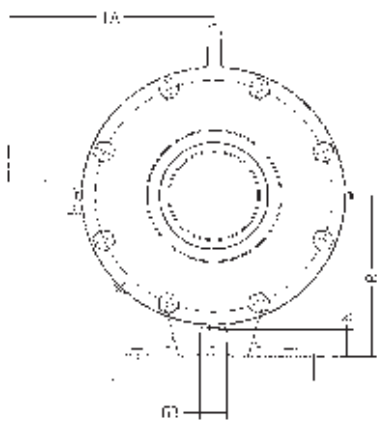

DN 32 + 40

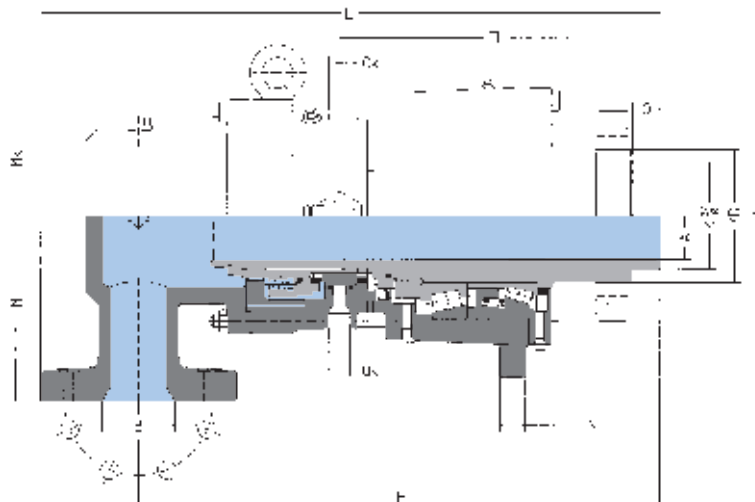
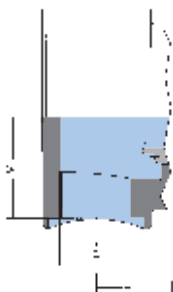

DN	32	40	50	65	80	100	125	150
Type	DCL 132 F	DCL 140 F	DCL 150 F	DCL 165 F	DCL 180 F	DCL 1100 F	DCL 1125 F	DCL 1150 F
Ordering no.	1114845	1114859	1114873	1114887	1114901	1114915	1114927	1114935
Ø A		40						
B (=DIN 2635)		G 1 1/2						
E		390						
F		350						
H		16						
Ø J		192						
Ø K G7/h8		50						
M		68						
N		78,5						
O		25						
R		141						
Fk		241						
GB		18						
KD		M95 x 2						
Mk		76						
NT		45						
Qk		G 3/8						
TA		168						
Weight (kg)		20						

DCLB 2

For the passage of one medium in two directions
for rotating inner pipe

DN 32 – 150

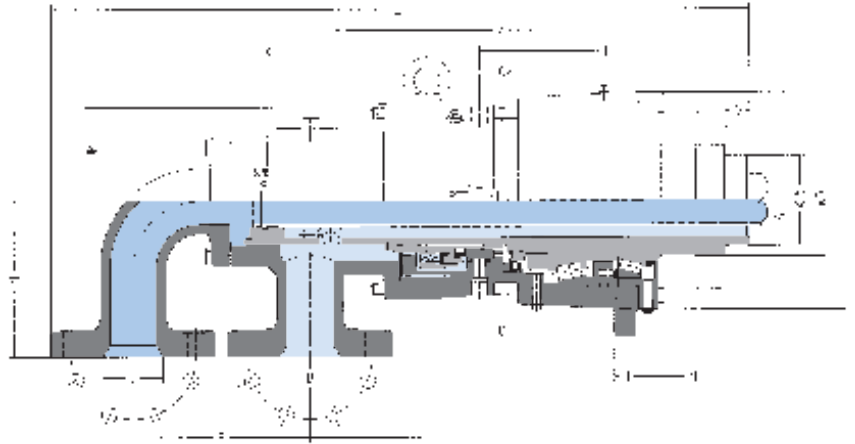
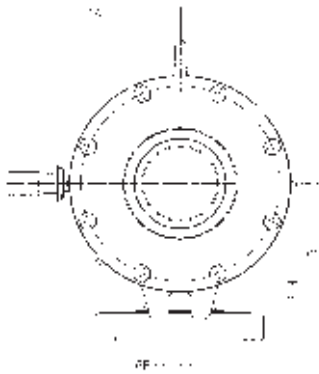

DN 32 + 40

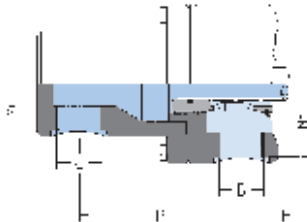

DN	32	40	50	65	80	100	125	150
Type	DCLB 232 F	DCLB 240 F	DCLB 250 F	DCLB 265 F	DCLB 280 F	DCLB 2100 F	DCLB 2125 F	DCLB 2150 F
Ordering no.	1114853	1114867	1114881	1114896	1114909	1114923	1114931	1114939
Ø A		40	50	63	85	98	120	
B (=DIN 2635)		G 1 1/4	DN 40	DN 50	DN 65	DN 80	DN 100	
C (=DIN 2635)		G 1 1/4	DN 40	DN 50	DN 65	DN 80	DN 100	
E		539	605	727	805,5	847	952	
F		350	365	434,5	505	497	540	
H		16	18	18	25	25	30	
Ø J		192	200	230	252	252	304	
Ø K G7/h8		50	65	85	105	114	150	
M (DN 32+40; Mb/Mc)		66,5 / 42,5	200	250	180	195	230	
N		78,5	86	89,5	129,5	125,5	149	
O		25	25	25	27	27	35	
P		150	165	210	205	245	285	
R		141	140	160	157	157	187	
Ø W G7/e8		28	35	45	60	75	88	
X		36	35	30	40	45	50	
Z		414	425	493	575	544,5	600,5	
Fk		241	255,5	303	309,5	295,5	334,5	
GB		18	20	25	26	26	30	
KD		M95 x 2	M95 x 2	M120 x 2	M130 x 2	M140 x 2	M175 x 2	
Mk		76	80	83,5	109	113	113	
NT		45	40	45	24	24	27	
Qk		G 3/8	G 1/2	G 1/2	G 1/2	G 1/2	G 1/2	
TA		168	169	179	196	200	208,5	
Weight (kg)		approx. 25	approx. 65	approx. 95	approx. 114	approx. 126	approx. 300	

DC 1

For the passage of one medium in one direction

DN 32 - 100

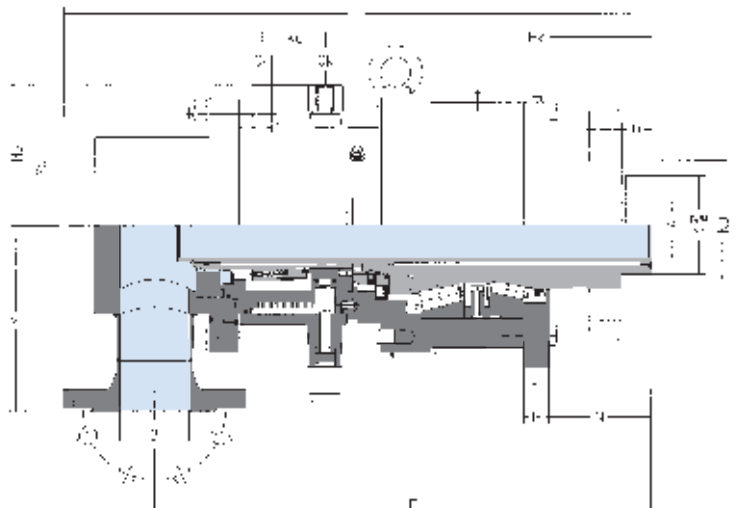
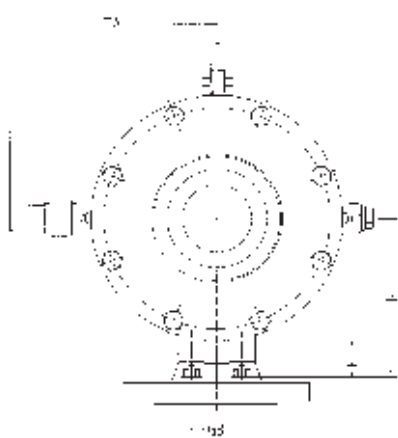

DN	32	40	50	65	80	100
Type	DC 132 F	DC 140 F	DC 150 F	DC 165 F	DC 180 F	DC 1100 F
Ordering no.	1114153	1114203	1114253	1114303	1114353	1114403
Ø A	32	40	50	66	90	110
B (=DIN 2635)	DN 32	DN 40	DN 50	DN 65	DN 80	DN 100
E	414	465	553	608	665	743
F	344	390	470,5	515	565	625
H	13,5	16	20	25	25	25
Ø J	178	198	236	260	310	345
Ø K G7/h8	55	70	80	100	135	160
M	160	190	212	190	250	307
N	67	78	80	103	115	130
O	20	25	25	30	35	35
R	115	130	150	162	192	209
Fk	220	256	282	328	384	422
GB	16,5	15	20	25	35	45
Ka	44,5	47,5	60,5	64,5	62,5	62,5
KD	M70 x 2	M95 x 2	M110 x 2	M130 x 2	M165 x 3	M 195 x 3
Ma	82	91,5	102	113	130	142
Me	108,5	117,5	131,5	142,5	159,5	171,5
NT	39	45	37	37	37	36,5
Qk	G 3/8	G 3/8	G 1/2	G 1/2	G 1/2	G 1/2
TA	181,5	191	195	206,5	222,5	234,5
Weight (kg)						

DCB 2

For the passage of one medium in two directions
for rotating inner pipe

DN 32-100

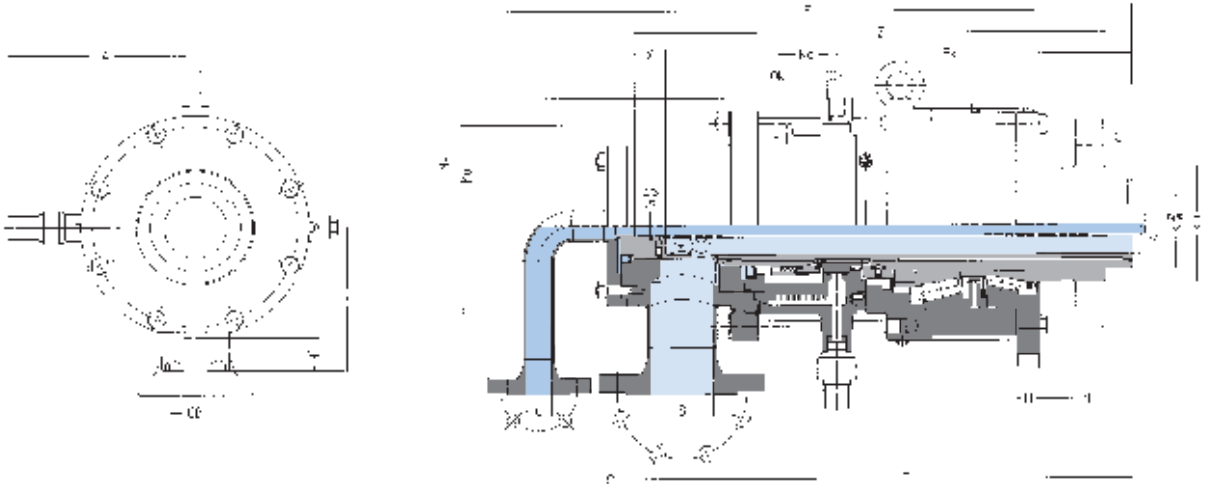

DN	32	40	50	65	80	100
Type	DCB 232 F	DCB 240 F	DCB 250 F	DCB 265 F	DCB 280 F	DCB 2100 F
Ordering no.	1114161	1114211	1114261	1114311	1114361	1114411
Ø A	32	40	50	66	90	110
B (=DIN 2635)	DN 32	DN 40	DN 50	DN 65	DN 80	DN 100
C (=DIN 2635)	DN 15	DN 20	DN 25	DN 32	DN 40	DN 50
E	519	580	682,5	761	825	917,5
F	344	390	470,5	515	565	625
H	13,5	16	20	25	25	25
Ø J	178	198	236	260	310	345
Ø K G7/h8	55	80	80	100	135	160
(M)	160	190	210	190	250	307
N	67	78	80	103	115	130
O	20	25	25	30	35	35
P	127,5	137,5	154,5	176	185	210
R	115	130	150	162	192	209
X	20	20	34	35	45	50
Ø W G7/e8	16	17	25	25	37	45
Z	377	426	532,5	568	638	720
Fk	220	256	282	328	384	422
GB	16,5	15	20	25	35	45
Ka	44,5	47,5	60,5	64,5	62,5	62,5
KD	M70 x 2	M95 x 2	M110 x 2	M130 x 2	M 165 x 3	M195 x 3
Ma	82	91,5	102	113	130	142
Me	108,5	117,5	131,5	142,5	159,5	171,5
NT	39	45	37	37	37	36,5
Qk	G 3/8	G 3/8	G 1/2	G 1/2	G 1/2	G 1/2
TA	181,5	191	195	206,5	222,5	234,5
Weight (kg)			approx. 64			approx. 272

Screw Flange Connections

for series DCL 1 + DCLB 2 + DC 1 + DCB 2

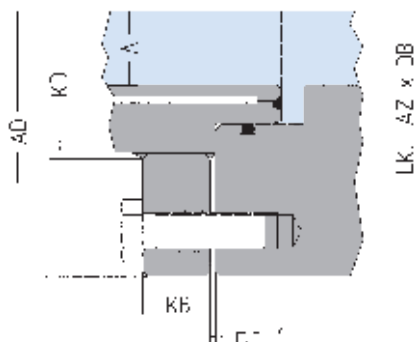

Screw flange connections DCL DN 32 – 150

DN	Type	Ordering no.	Ø A	Ø AD	Ø LK	AZ x Ø DB	Ø KD	KB
32								
40	FG 40-1	1190469-001	40	160	130	8 x Ø11	M 95 x 2	25
50	FG 50-2	1190470-002	50	165	125	8 x Ø14	M 95 x 2	25
65	FG 65-6	1190471-006	63	180	150	8 x Ø14	M 120 x 2	30
80	FG 80-6	1190472-006	85	205	170	8 x Ø14	M 130 x 2	30
100	FG 100-9	1190473-009	98	228	195	8 x Ø18	M 140 x 2	30
125	FG 125-1	1190474-001	120	250	210	8 x Ø18	M 175 x 2	35
150								

Screw flange connections DC DN 32 – 100

DN	Type	Ordering no.	Ø A	Ø AD	Ø LK	AZ x Ø DB	Ø KD	KB
32	FG 32-3	1190468-003	32	150	115	4 x Ø14	M 70 x 2	20
40	FG 40-1	1190469-001	40	160	130	8 x Ø11	M 95 x 2	25
50	FG 50-3	1190470-003	50	175	140	8 x Ø14	M 110 x 2	25
65	FG 65-2	1190471-002	66	200	170	8 x Ø18	M 130 x 2	30
80	FG 80-2	1190472-002	90	260	220	8 x Ø18	M 165 x 3	35
100	FG 100-4	1190473-004	110	280	240	8 x Ø18	M 195 x 3	40

Spare Parts

for series DCL 1 + DCLB 2 – DN 32-150

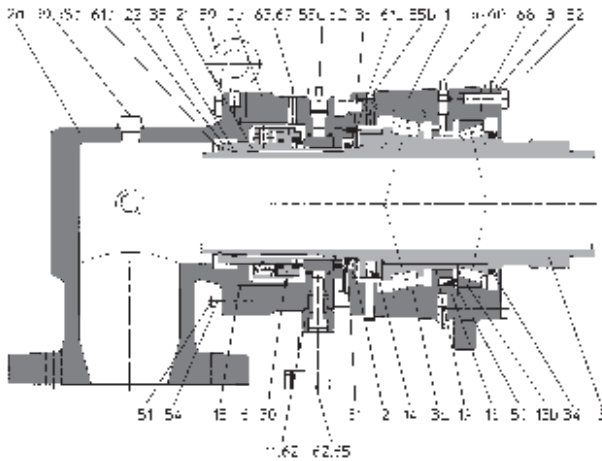

DCL 1

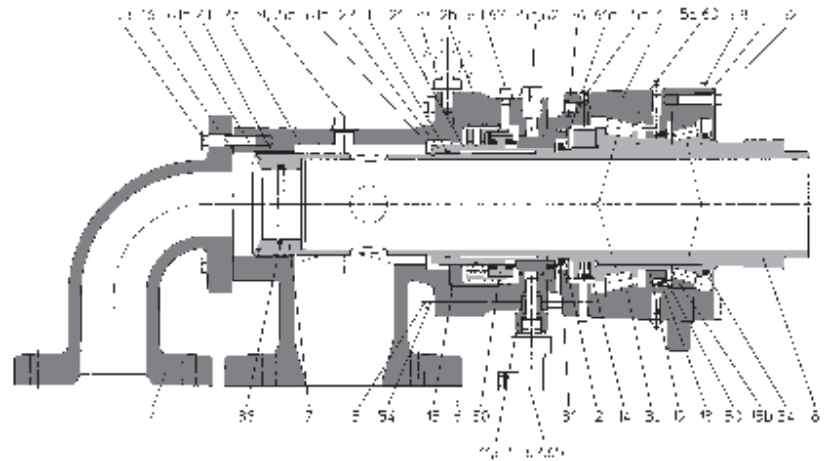

DCLB 2

DN	32	40	50	65	80	100	125	150
6 Insulating disk			3511033-090	3511034-126	3511035-174	3511036-151	3511037-083	
7 Rotor bushing			1114282-132	1114332-127	1114382-177	1105721-387	1105796-277	
12 Shaft bush / sealing disk			1114278-082	1114328-129	1114378-176	1114414-145	1114474-085	
13a Tapered roller bearing			3510154	3510055	3510025-250	3510025-250	3510072-250	
13b Tapered roller bearing			3510172	3510056	3510021-250	3510021-250	3510178	
15 Flat packing			1110368-088	1110594-070	3512356-149	3512356-149	1105815-352	
16 Flat packing			1103449-261	1103799-419	1110519-154	3512092	3512271	
30 Rot. mechanical seal compl.			3511158-002	3511159-001	3511160-001	3511154-001	3511162-001	
31 Shaft seal			3511179-001	3511972	3511784	3511984	3511986	
34 Shaft seal			3511982	3511984	3511986	3511986	3511988	
35 Ring			3511445	3511446	3511447	3511448-002	3511449-001	
36 O ring			3511894-001	3511869-001	3511901-001	3512506-001	3511772-001	
38 O ring			3511733-002	3511769	3511946	3511825	3511826	
39 Sealing ring			-	-	3502115-001 3x	3502115-001 3x	3502115-001 3x	
41 Sliding bearing			3510523	3510496-001	3510478	3510536	3510493-001	
50 Spring			3511525 16x	3511585 2x	3511558 24x	3511558 24x	3511557 16x	
61a Locking ring circlip			3501004-001	3501009-001	3501037-001	3501006-001	3501031-003	
61b Locking ring circlip			3501232-001	3501236-001	3501241	---	---	
62 Sealing ring			3502115-001 3x	3502115-001 3x	3502115-001 3x	3502115-001 3x	3502115-001 3x	
63 Sealing ring			3502130-001 2x	3502130-0012x	3502130-001 2x	3502130-001 2x	3502130-001 2x	
65 Temperature monitor			3636027-003	3636027-003	3636027-003	3636027-003	3636027-003	

Please specify exact type designation when inquiring or placing orders!

Spare Parts

for series DC 1 + DCB 2 – DN 32-100

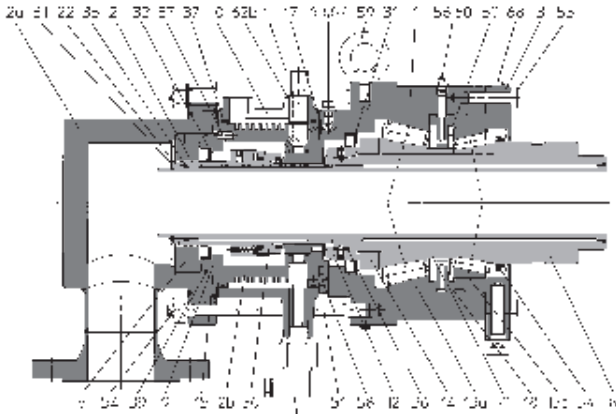

DC 1

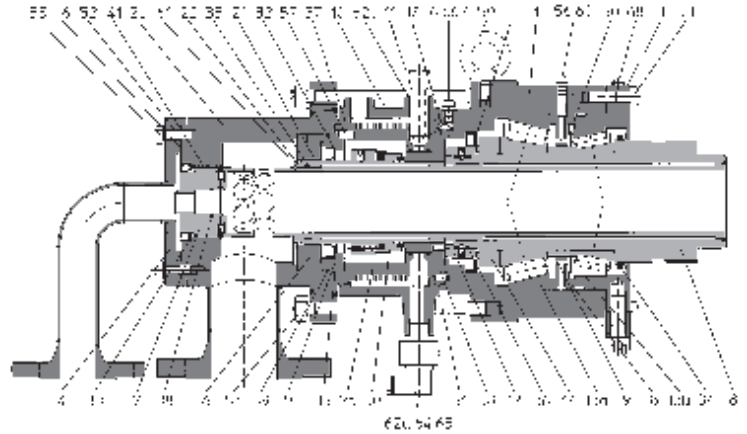

DCB 2

DN	32	40	50	65	80	100
6 Insulating disk	3511031-126	3511032-061		3511034-110	3511035-117	3511036-108
7 Rotor bushing	1114182-128	1114232-072		1114332-113	1114382-121	1114432-110
12 Shaft bush	1114178-096	1114228-075		1114328-092	1114378-069	1114428-117
13a Tapered roller bearing	3510049	3510053		3510055	3510057	3510059
13b Tapered roller bearing	3510052	3510054		3510056	3510058	3510072-250
15 Flat packing	1114293-059	3512355-083		1114343-071	3512355-071	3512356-071
16 Flat packing	3512014	1110324-129		1114344-072	3512355-124	3512018
17 Flat packing	1114449-116 2x	1114449-116 2x		1114449-116 2x	1114449-116 2x	1114449-116 2x
21 Sealing bush	1114188-122	1114238-059		1114338-093	1114388-073	1114438-073
30 Rot. mechanical seal compl.	3511156-001	3511157-001		3511159-001	3511160-001	3511161-001
31 Shaft seal	3511167-001	3511180-001		3511179-001	3511178-001	3511181-001
32 Shaft seal	3511168-001	3511966		3511176-001	3511179-001	3511182
33 Shaft seal	3511169-002	3511172-002		3511966-002	3511180-002	3511183-001
34 Shaft seal	3511993	3511996		3511985	3511988	3511995
35 Ring	3511232	3511444		3511446	3511447	3511256
36 O-Ring	3511870-001 2x	3511836-001 2x		3511709-001 2x	3511719-001 2x	3511717-001 2x
37 O-Ring	35117712x	3511837 2x		3511758 2x	3511762 2x	3511772 2x
38 O-Ring	3511718-012	3511838-012		3511731-012	3511814-002	3511769
39 O-Ring	3511709	3511715		3511887	3511834	3511833
41 Sliding bearing	3510507-001	1114249-076		3510496-001	3510492-001	3510493-001
50 Spring	3511582 2x	3511559 16x		3511585 2x	3511586 2x	3511587 2x
61 Locking ring circlip	3501017-001	3501027		3501009-001	3501037-001	3501007-003
62a Sealing ring	3502115-001 2x	3502115-001 2x		3502115-001 2x	3502115-001 2x	3502115-001 2x
62b Sealing ring	3502116-001	3502116-001		3502115-001	3502115-001	3502115-001
63 Sealing ring	3502130-001 2x	3502130-001 2x		3502130-001 2x	3502130-001 2x	3502130-001 2x
65 Temperature monitor	3636027-004	3636027-004		3636027-004	3636027-004	3636027-004

Please specify exact type designation when inquiring or placing orders!

**Christian Maier GmbH & Co. KG
Maschinenfabrik**

Wuerzburger Straße 67-69
D-89520 Heidenheim

P.O.Box 1609
D-89506 Heidenheim

☎ + 49 (0) 73 21 / 317-0
✉ + 49 (0) 73 21 / 317-139 (Export)
☎ + 49 (0) 73 21 / 317-239

vkd@maier-heidenheim.de
www.maier-heidenheim.de

Branch Offices & Service Stations:

Maier Italia Srl

Via Enrico Toti 3
I-21040 Gerenzano (VA)

☎ + 39-02-96 24 82 88
✉ + 39-02-96 36 96 95

info@maier-italia.com
www.maier-italia.com

Maier America LLC

6649 Peachtree Industrial Blvd., Suite O
Norcross, GA 30092 - USA

☎ +1-770-409 0022
✉ +1-770-409 0069

info@maieramerica.com
www.maieramerica.com

