

Rotary Joints

Series DQ



Rotary Joints Series DQ

DQ series Rotary Joints

are designed to accommodate a range of manufacturing / production applications. These specialized Rotary Joints have exceptionally proven tolerance in a number of process environments including thermal oil tolerance up to 752°F (400°C), and rotational speed tolerance up to 2,000 RPM. Applied uses are commonly found in a variety of specialized industries and processes including polymer, lamination and coating applications, paper and textile manufacturing processes including non-woven and textile calenders, industrial dryers and rotary reaction vessels.

The US and internationally patented DQ system prevents the common failure consequence of carbonization and cracking caused by hot thermal oil contact with atmospheric oxygen. This chemical reaction creates seal damage that causes the problems of improper hot oil and oil vapor discharge.

The specially designed failure avoidance features of the DQ system provide unique advantages: Atmospheric oxygen is isolated from the hot oil by a barrier fluid. A cooling unit is used with the DQ ,DQT and DQTX series to cool the barrier fluid using the same (or compatible) heat transfer medium as in the main circuit.

The DQ 5th Generation series requires no extra cooling unit. Instead it uses the existing lubricating oil circuit from the production machine. This eliminates the need of the cooling unit and allows considerably higher speeds. The DQL version does not require a cooling unit because of its temperature limit of 482°F (250°C).

Advantages and Features

- Much longer service life than other rotary joints.
- Longer uninterrupted run-times and no unscheduled maintenance, since the rotary joint functions is efficiently monitored via the cooling unit.
- Significantly reduced risk of thermal oil leakage and escape of oil vapors.
- The primary seal is pressure balanced with a low torque rate A seal protector disk provides protection against penetration by foreign particles. The externally loaded mechanical seal provides added safety protection.
- The secondary seal is not subject to stress and is protected by the cooled barrier fluid.
- The double wall rotor protects the bearings from extended high temperature exposure and prevents energy loss.
- The functions of the rotary joints are monitored continuously via the control elements on the cooling unit. In case of leakage, production can continue until the next scheduled shut-down due to temporary containment of reusable filtered oil within the cooling unit.

Additional Technical Design Details:

- Housing made from spheroidal graphite cast iron (up to 662°F / 350°C) or from high-temperature steel suitable for applications over 662°F (350°C).
- Unit sizes 1" to 1 1/2" with ball bearings; 2" to 8" with self-adjusting tapered roller bearings.
- DQ and DQT use conditioned oil (cooled and filtered) from the cooling oil loop. No need for re-lubrication. DQL uses high temperature grease for bearing lubrication.
- A sensor (provided by customer) for monitoring the bearings can be attached to the screw plug of the cooling oil circuit.
- Quick release K-flange and conical inner rings are used to connect the rotary joint to the roll journal.
- Radial and axial housing connections are equipped with ANSI standard flanges. DIN or other standards upon request.
- Barrier fluid connections with internal ISO 228 threads (British standard parallel pipe thread).
- Prevention of rotation by means of anti-rotation forks that can be mounted at 8 x 45° positions.
- Static support in the rotor for a rotating inner pipe prevents wear between inner pipe and bushing.
- For use of one cooling unit for several rotary joints, a flow distributor is recommended to distribute cooling oil evenly to several rotary joints.
- For further information and safety notations please refer to the Operating Instructions at www.maier-heidenheim.de or www.maieramerica.com. Please call us for user ID and password.

Application data

Series		DQL	DQ	DQT	DQTX	DQ5
Design		1, B2	1, B2	1, B2	1, B2	1, B2
Nominal diameter DN inch		1...6	1...8	1...6	1...6	1...8
Nominal diameter DN mm		25...150	25...200	25...150	25...150	25...200
Additional device for cooling and lubrication		–	KE, KEW	KE, KEW	KE, KEW	–
Medium		thermal oil	thermal oil	thermal oil	thermal oil	thermal oil
Temperature	max °F	482	572	662	752	572
	max °C	250	300	350	400	300
Pressure PN	max psi	145	145	145	189	145
	max bar	10	10	10	13	10
Speed	max rpm	<u>2,000</u>	<u>4,000</u>	<u>4,000</u>	<u>4,000</u>	<u>5,150</u>
		DN (in)	DN (in)	DN (in)	DN (in)	DN (in)

Overspeed limitation

DN	25	32	40	50	65	80	100	125	150	200
Speed DQ 4th Gen. max.min ⁻¹	1300	1200	1100	1000	900	800	700	600	500	450
Speed DQ 5th Gen. max.min ⁻¹	–	2400	2200	2000	1800	1550	1250	1000	825	580

* Speed depends on temperature – for more than 392°F (200 °C) contact us.
DN 8" and DQ5 upon request. Avoid the combination of maximum values.

Ordering instructions

Example:

DQ	T	B	2	50	K	-701
----	---	---	---	----	---	------

Series DQ	
DQL	up to 482°F / 250°C
DQ	up to 572°F / 300°C
DQT	up to 662°F / 350°C
DQTX	up to 752°F / 400°C
DQ5	up to 572°F / 300°C
B	Design for rotating inner pipe with static seal between inlet and outlet
1	Number of housing connections for one-way flow (only upon request)
2	for two-way flow
Nominal diameter DN (≙ dimension A)	
1	1 1/4 1 1/2 2 2 1/2 3 1/2 4 5 6 8 (inch)
25	32 40 50 65 80 100 125 150 200 (mm)
K	Rotor connection for K-flange
-700	US standard
>700	Consecutive numbers for special designs; numbering by factory.
-100	European standard
>100	Consecutive numbers for special designs; numbering by factory.

DQB2 DN 1"-1 1/2" (25-40 mm)

for two way flow of a medium designed for rotating inner pipe

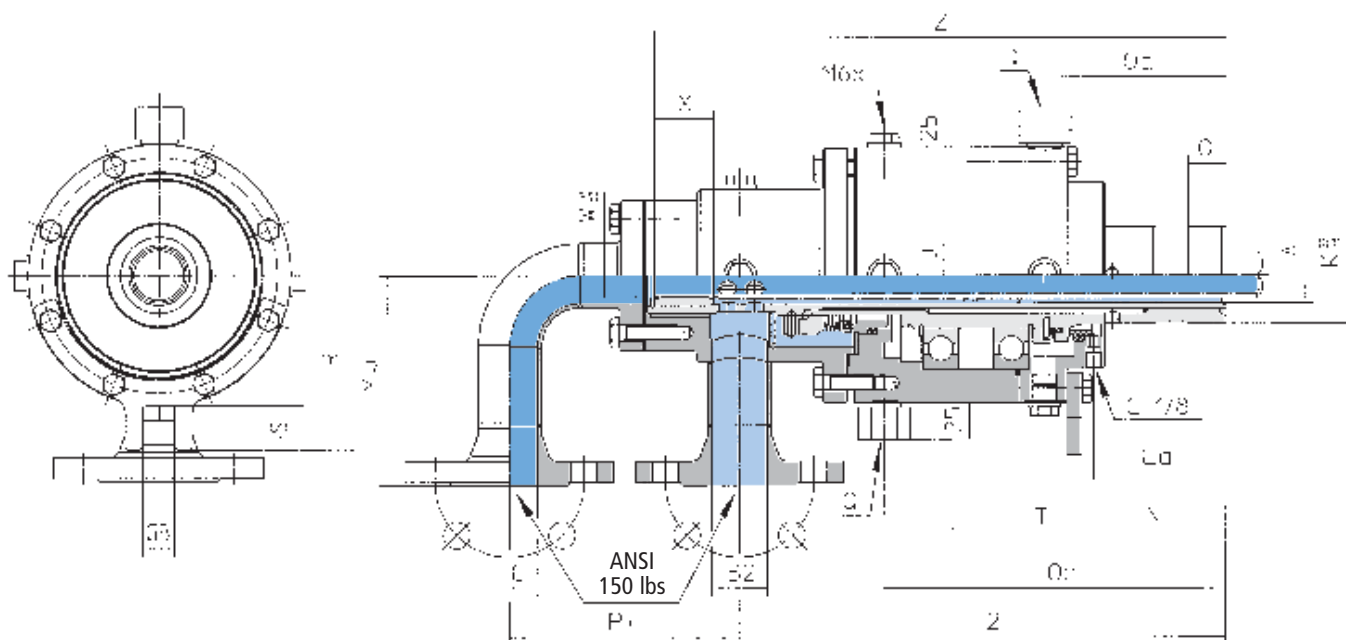

DN	1	1 1/4	1 1/2
Type	DQLB 225 K-700	DQLB 232 K-700	DQLB 240 K-700
Order-No.	1110097-700	1110172-700	1110247-700
Type	DQB 225 K-700	DQB 232 K-700	DQB 240 K-700
Order-No.	1110081-700	1110156-700	1110231-700
Type	DQTB 225 K-700	DQTB 232 K-700	DQTB 240 K-700
Order-No.	1110091-700	1110166-700	1110241-700
Ø A	0.984	1.260	1.496
B2	3/4	1	1 1/4
C	3/4	1	1 1/4
Ea	2.795	2.992	3.465
F2	11.024	11.220	12.795
Ø J	5.906	5.906	6.693
Ø K G7/h8	1.772	1.969	2.559
M±3	4.724	4.724	5.512
N	3.031	3.228	3.780
O	0.787	0.984	0.984
P±3	5.512	5.512	6.102
Q (4x90°)	G 1/2	G 1/2	G 1/2
Qa	3.937	4.134	4.764
Qe	7.205	7.402	8.976
R	4.016	4.016	4.724
S	0.945	0.945	0.984
T	0.394	0.394	0.394
Ø W G7/e8	0.709	0.945	1.142
X	1.181	1.181	1.575
Z	12.795	12.992	15.079
GB	0.787	0.787	0.787
Weight (lbs)	55	55	77

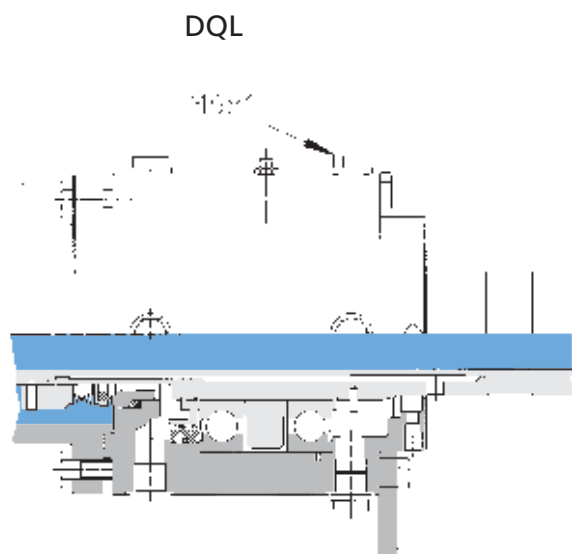

DQB2 DN 2"-6" (50-150 mm)

for two way flow of a medium designed for rotating inner pipe

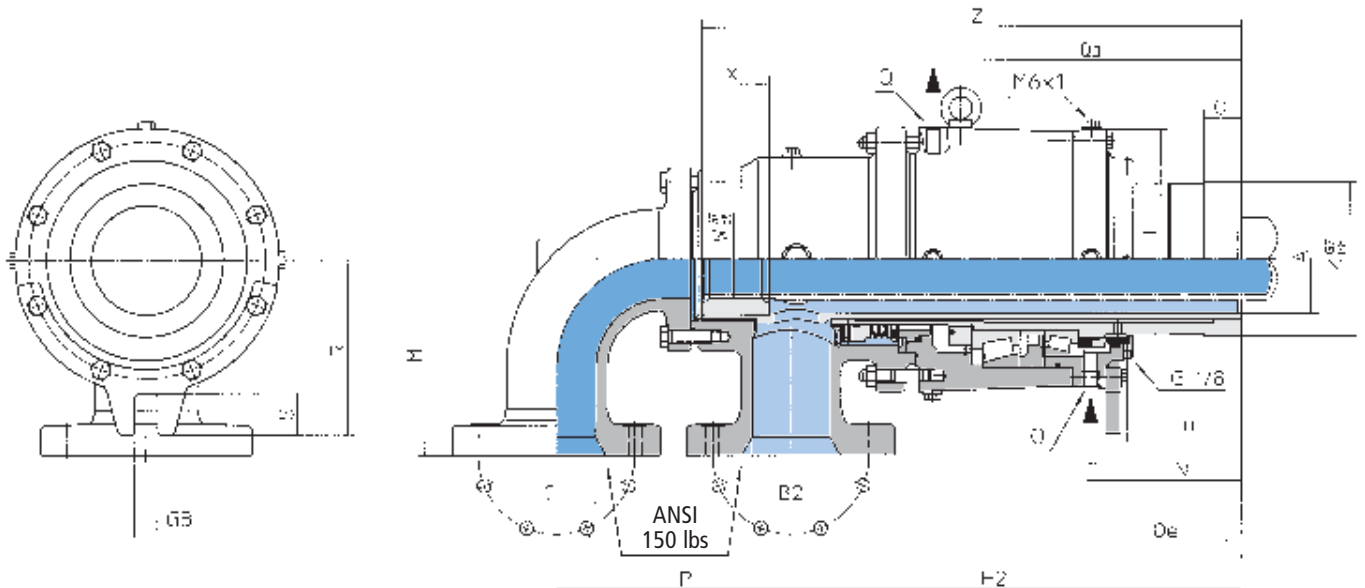

DN	2	2 1/2	3 1/2	4	5	6
Type	DQLB 250 K-700	DQLB 265 K-700	DQLB 280 K-700	DQLB 2100 K-700	DQLB 2125 K-700	DQLB 2150 K-700
Order-No.	1110322-700	1110397-700	1110472-700	1110547-700	1110622-700	1110697-700
Type	DQB 250 K-700	DQB 265 K-700	DQB 280 K-700	DQB 2100 K-700	DQB 2125 K-700	DQB 2150 K-700
Order-No.	1110306-700	1110381-700	1110456-700	1110531-700	1110606-700	1110681-700
Type	DQTB 250 K-700	DQTB 265 K-700	DQTB 280 K-700	DQB 2100 K-700	DQB 2125 K-700	DQB 2150 K-700
Order-No.	1110316-700	1110391-700	1110466-700	1110541-700	1110616-700	1110691-700
Ø A	1.969	2.598	3.189	3.898	4.685	5.748
B2	1 1/2	2	2 1/2	3	4	5
C	1 1/2	2	2 1/2	3	4	5
Ea	3.976	4.567	4.705	5.295	5.453	5.984
F2	15.748	16.732	17.913	19.764	22.047	23.622
Ø J	7.323	8.031	9.213	10.433	12.205	13.858
Ø K G7/h8	3.346	4.134	4.488	5.315	6.693	8.031
M±3	5.709	6.693	7.087	7.677	9.055	10.236
N	3.268	4.921	5.177	5.768	5.866	6.299
O	1.181	1.378	1.575	1.772	1.969	1.969
P±3	6.693	7.087	8.071	8.858	11.024	12.402
Q (4x90°)	G 1/2	G 1/2	G 1/2	G 1/2	G 1/2	G 1/2
Qa	10.906	12.146	12.795	14.252	15.787	16.142
Qe	4.902	6.063	6.476	7.067	7.461	7.874
R	4.528	5.118	6.102	6.969	8.071	9.134
S	0.906	0.984	1.437	2.165	1.969	2.165
T	0.394	0.394	0.591	0.591	0.591	0.787
Ø W G7/e8	1.457	1.772	2.362	2.953	3.465	4.134
X	1.969	1.969	1.575	1.969	3.150	3.543
Z	18.110	19.685	21.063	23.110	26.614	28.346
GB	0.866	0.866	1.024	1.181	1.181	1.181
Weight (lbs)	110	150	209	287	459	626

DQL

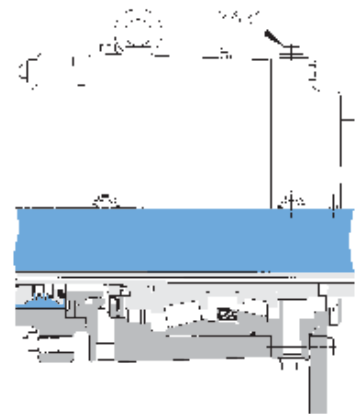

KE + KEW Cooling Unit

Cooling Unit KE / KEW

Rotary Joints of series DQ are a part of an US and internationally patented system that prevents the common failure consequence of carbonization and cracking caused by hot thermal oil contact with atmospheric oxygen. This chemical reaction would cause seal damage which would result in improper hot oil and oil vapor leakage. To prevent this consequence, series DQ are especially designed to be used in conjunction with a barrier fluid as cooling medium (use of the same heat transfer fluid as in the main circuit is recommended). This combined utilization is a unique function that maximizes failure avoidance throughout manufacturing processes.

The barrier fluid is conditioned (filtered and cooled) by the KE / KEW external cooling unit component. Type KE is equipped with an air cooled heat exchanger. Type KEW has a water cooled heat exchanger. The cooling unit also serves as a constant monitoring unit of the rotary joints' functions. As a result, the cooling unit has the triple bonus features of monitoring the rotary joints while it simultaneously cools and filters the barrier fluid. The cooling unit also includes special monitoring elements which transmit signals to a customer provided control unit (PLC). In case of any leakage at the rotary joint it is possible to continue operation until the next scheduled shut-down, since the leaking oil is collected by the cooling unit.



One cooling unit can simultaneously service multiple rotary joints. So that each rotary joint is equally supplied by the cooling unit, a flow distributor is recommended.

Operating Principle

Hot thermal oil flows through the rotary joint and is sealed by the mechanical seal (primary seal P). If the hot thermal oil comes in contact with atmospheric oxygen in the sealing gap (P), chemical reaction (carbonization) would be the result, leading to damages at seal (P) and bearing (L). Thus, a barrier fluid (second oil circuit) flows through the bearing and sealing area of the rotary joint in order to cool and lubricate these components. In addition, the primary seal (P) is isolated from atmospheric oxygen. The barrier fluid is sealed against atmosphere by a second seal (secondary seal S) and processed by cooling unit KE / KEW. These unique isolation measures (I) support the desired effect of the barrier fluid.

This solution improves the wear resistance and operational reliability of the rotary joints significantly compared to conventional rotary joints.

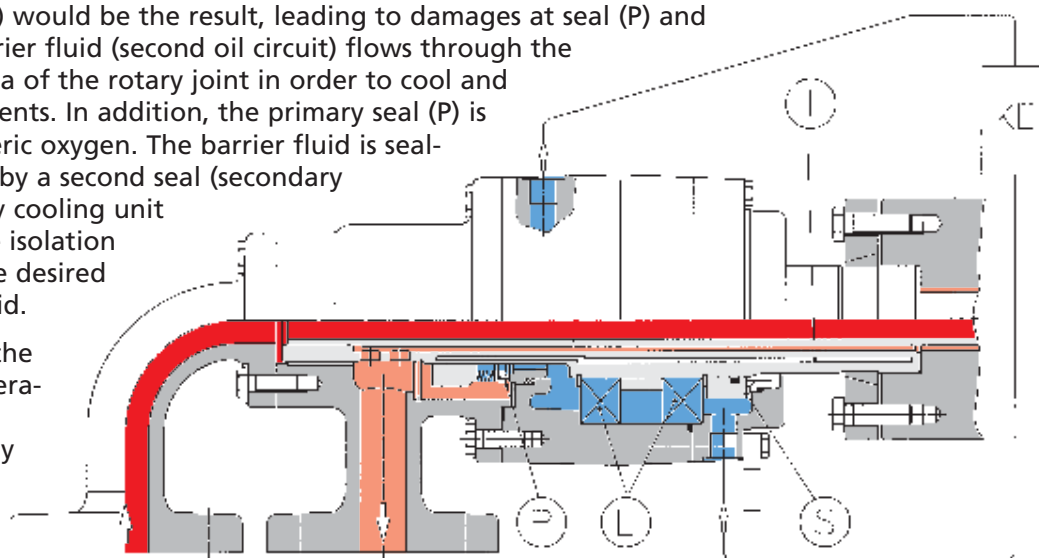

Cooling Circuit for two or more Rotary Joints

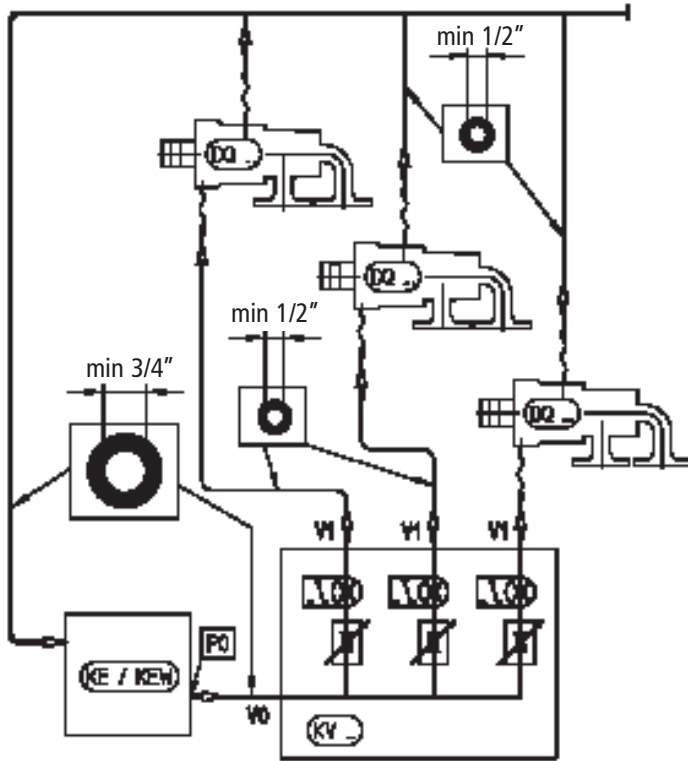

For two or more rotary joints the cooling oil circuit is to be installed as shown in the diagram. A cooling oil distributor (KV) is recommended to compensate for differences in installation height, pipe length and cross sectional areas. The oil distributor ensures an even oil supply (V1) to the rotary joints and transmits an electric signal to the control unit, if the correct flow is not maintained.

Maximum pipe length is 82 ft (25 m). Please note the minimum cross section of the pipes according to the diagram.

The maximum admissible head loss (pump pressure P0) in the system is 72.5 psi (5 bar). For further information please refer to the Operating Instructions at www.maier-heidenheim.de or www.maieramerica.com. Please call us for user ID and password.

Features of the Cooling Unit

Integrated monitoring devices/alarms for temperature, flow rate, level min/max and filter condition will transmit an electric signal to the customer's PLC, if an alarm situation is present. For proper installation all necessary wiring, schematic and circuit diagrams will be supplied upon order.

Size of pump	gpm (l/min)	2.1 (8)	4.2 (16)	7.4 (28)
Type		KE 28-53	KE 28-52	-
Order no.		1192059-053	1192059-052	-
Type		KEW 28-41	KEW 28-51	KEW 28-40
Order no.		1192059-041	1192059-051	1192059-040
Nom. tank vol.	gal (l)	9.2 (35)	9.2 (35)	9.2 (35)
Motor power	50 Hz	0.37 kw, 380-420V	0.75 kw, 380-420V	0.75 kw, 380-420V
Circl.pump	gpm (l/min)	2.1 (8)	4.2 (16)	7.4 (28)
Cooling capacity* kw		8 (KE) / 10 (KEW)	12,5 (KE) / 16,5 (KEW)	20 (KEW)
Motor power	60 Hz	0.44 kw, 440-480V	0.9 kw, 440-480V	0.9 kw, 440-480V
Circl.pump	gpm (l/min)	2.53 (9.6)	5.07 (19.2)	8.88 (33.6)
Cooling capacity* kw		8 (KE) / 10 (KEW)	12,5 (KE) / 16,5 (KEW)	20 (KEW)

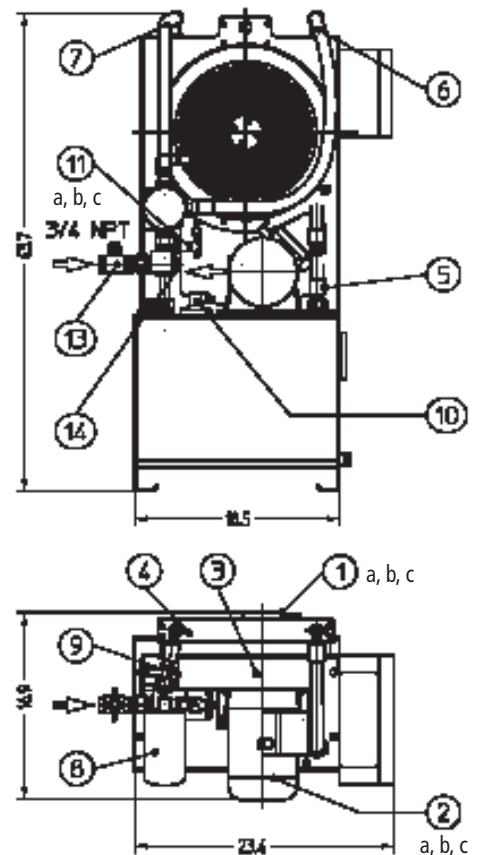

Control voltage 24V or 220V. Design according 2006/42/CE. Standard color RAL 7032 pebble grey structured. * Air or water temperature < 86°F (30°C) at inlet.

See parts list page 8

Features of the Cooling Unit

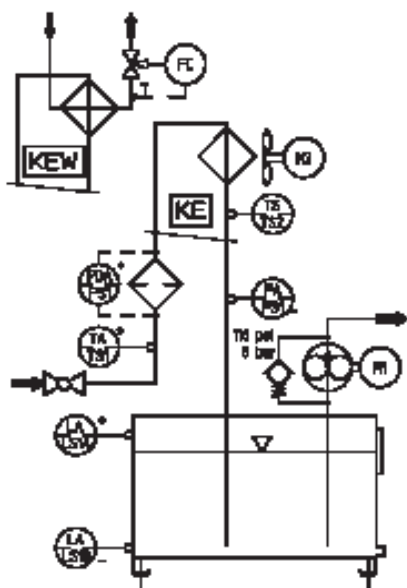

M1		3-phase motor for pumps	0.75 / 0.9 kW, insulation cl. F, IP 54 380-420 V/2.1-1.9 A/50 Hz/1400 rpm 440-485 V/2.0-1.8 A/60 Hz/1680 rpm
M2		3-phase motor for air cooler only with KE 28	0.18 kW insulation class F, IP 44 380-420 V/0.31 A 50 Hz/2600 rpm
FS1	FA.	Flow guard flow rate reached = 1	IP 65, AC/DC max. 250 V, max. 2 A, 60 W
TS1	TA ⁺	Temperature guard Oil temperature too high = 0	IP 65, AC/DC, max 250 V 12 V: max. 10 A 24 V: max. 5 A
LS1A	LA ⁺	Level indicator max Max. oil level reached = 0	IP 65, AC/DC
LS1B	LA.	Level indicator min Min. oil level reached = 0	max. 250 V, 55 W
TS2	TS	Controller for oil/air cooler only with KE 28	IP 65, AC/DC, max. 250 V 12 V: max. 10 A 24 V: max. 5 A
	FC	Control valve for oil/water heat exchanger only with KEW 28	non-electrical controller
PS1	PDA ⁺	Filter wear indicator Filter change = 0	IP 65, AC/DC, max. 250 V 220 V: max. 5 A, 24 V: max. 8 A

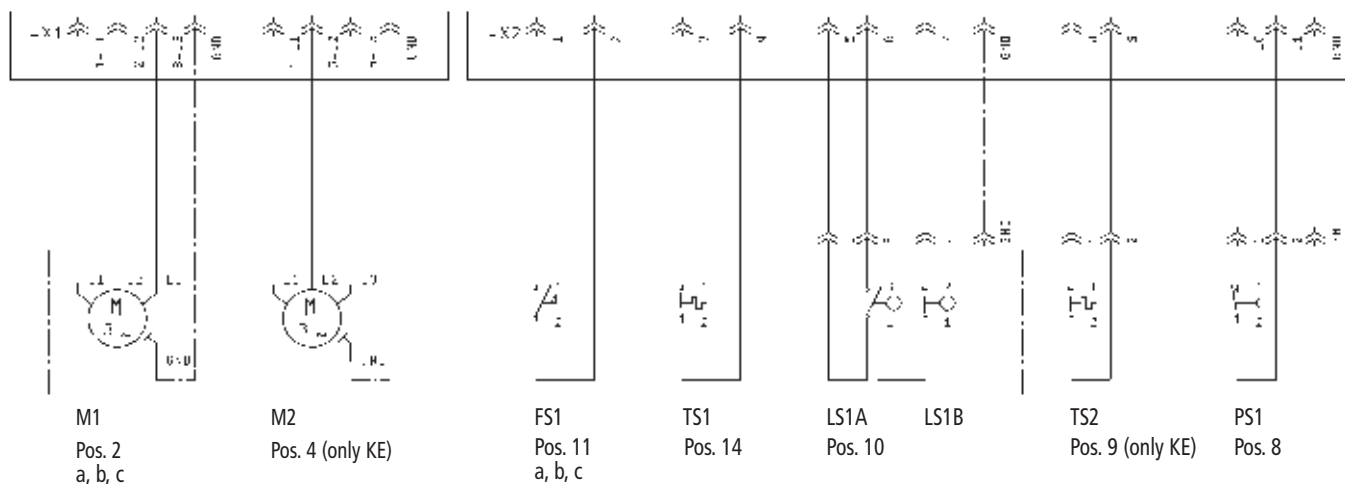

Spare Parts

Type	KE	KEW
1a Pump 2.1 gpm	3516157-001	3516157-001
1b Pump 4.2 gpm	3516157-001	3516157-001
1c Pump 7.4 gpm	3516157-002	3516157-002
2a El.motor for 1a	3631011-003	3631011-003
2b El.motor for 1b	3631017-001	3631017-001
2c El.motor for 1c	3631017-001	3631017-001
3 Coupling	3514092-002	3514092-002
4 Air heat exchanger	3516156-001	3516153-001
5 Hose 1	3513001-001	3513001-001
6 Hose 2	3513001-002	3513001-004

Type	KE	KEW
7 Hose 3	3513001-003	3513001-006
8 Filter cartridge	3516166	3516166
9 Temperature control	3636032-004	---
10 Level indicator	3636031-001	3636031-001
11a Flow guard for 1a (1.6 gpm)	3636026-001	3636026-001
11b Flow guard for 1b (3.1 gpm)	3636030-001	3636030-001
11c Flow guard for 1c (5.8 gpm)	3636030-002	3636030-002
12 Cooling water contr. valve	---	3516002-003
13 Ball valve	3516171-001	3516171-001
14 Temperature control	3636032-005	3636032-005

Please specify exact type designation of the cooling unit plus order no. when placing an inquiry or an order.

System Design Calculations

Initial Data

Nominal diameter of rotary joint	DN	inch
Thermal oil temperature	T1	°F
Thermal oil pressure	p1	psi
Speed	n	rpm
Number of rotary joints per unit	z	pieces

Calculation

Mechanical friction load per rotary joint $P_m = 0.105 * n * Mr / 1000$ (Mr from fig. 1)	=	kW
Thermal capacity per rotary joint (Pt from fig. 2)	=	kW
Cooling capacity per rotary joint $P_v = P_m + P_t$	=	kW
Required cooling capacity $P_{ke} * \geq Z * P_v$	=	kW
Required oil flow per unit: $Q \geq 1.35 * Z * P_v$	=	l/min / 3.78 = gal

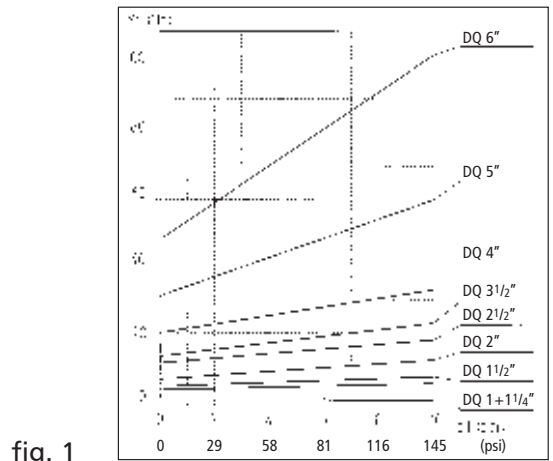

fig. 1

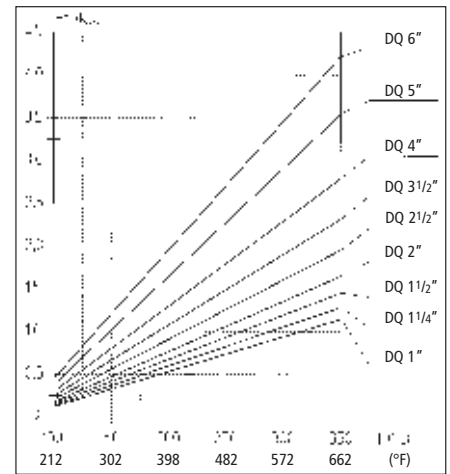
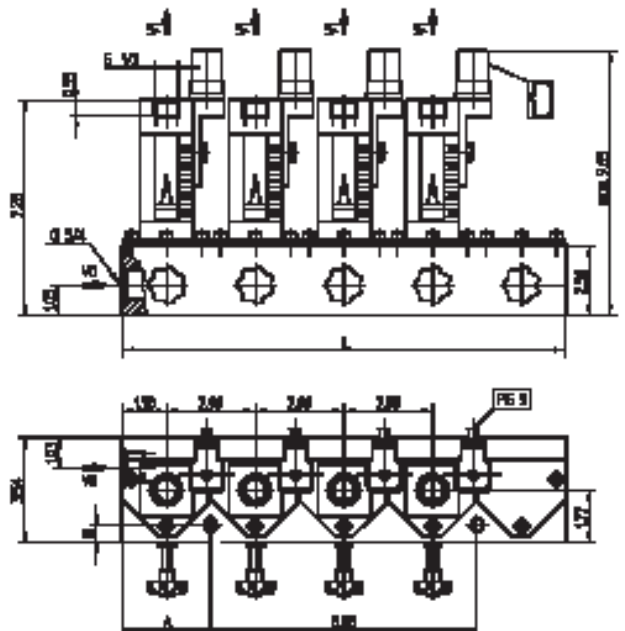

fig. 2

Cooling Oil Distributor

Oil volume / rotary joint V1	Number of rotary joints z			
	z = 2	z = 3	z = 4	z = 5
1-2.6 gpm Order no.		KV 10-3 3516158-103	KV 10-4 3516158-104	KV 10-5 3516158-105
2.6-5.3 gpm Order no.	KV 20-2 3516158-202			
L in	5.98	14.96	14.96	14.96
A in	0.43	2.99	2.99	2.99
B in	0.43	2.99	0.59	0.59

Capacity and size of all oil distributors must be adjusted to the pump performance. The above mentioned types are adjusted to a pump volume of 7.4 gpm.



Journal Flanges for K Rotor Connection

Material: carbon steel

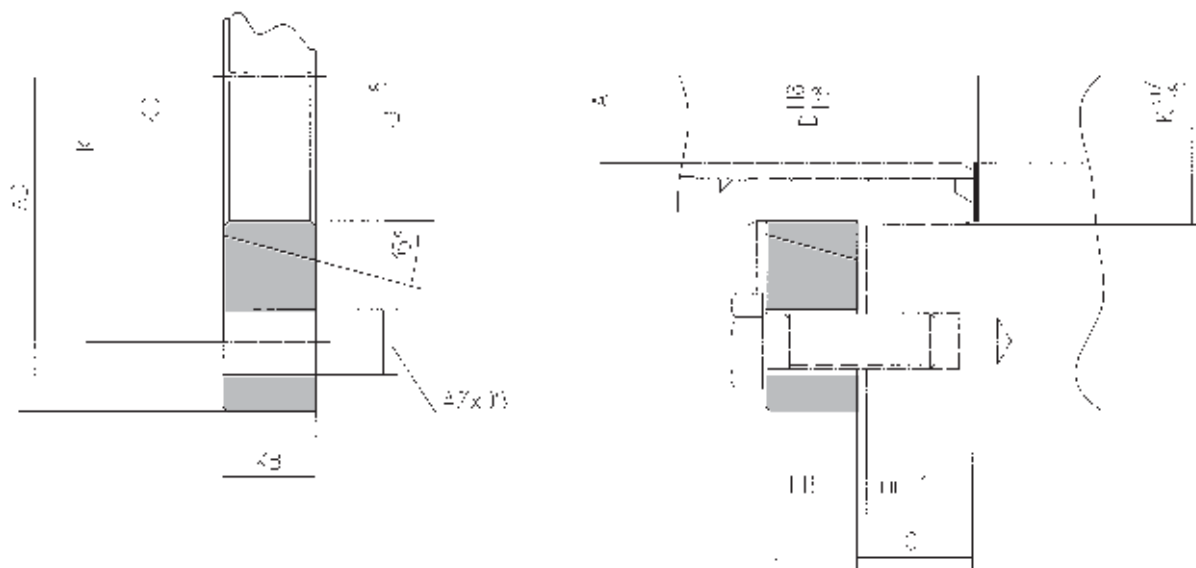

DN	K-flange	Order-No.	Inner ring	Order-No.	Gasket Order-No.	Ø A	Ø AD	Ø LK	AZ x Ø DB	Ø KD	Ø ID H8/h8	KB	Ø K G7/h8	O	EB
1	KF 32-500	1190434-500	IR 32-500	1190404-500	3512234	0.98	4.53	3.54	4 x 0.43	1.89	1.69	0.59	1.77	0.79	0.63
1 1/4	KF 40-500	1190435-500	IR 40-500	1190405-500	3512235	1.26	4.72	3.74	4 x 0.43	2.09	1.89	0.71	1.97	0.98	0.79
1 1/2	KF 50-500	1190436-500	IR 50-500	1190406-500	3512236	1.49	5.71	4.53	4 x 0.55	2.72	2.48	0.79	2.56	0.98	0.87
2	KF 65-500	1190437-500	IR 65-500	1190407-500	3512237	1.97	6.50	5.31	4 x 0.55	3.50	3.23	0.98	3.35	1.18	1.10
2 1/2	KF 80-500	1190438-500	IR 80-500	1190408-500	3512238	2.60	8.07	6.69	4 x 0.71	4.29	4.01	1.18	4.13	1.38	1.34
3 1/2	KF 100-500	1190439-500	IR 100-500	1190409-500	3512239	3.19	8.66	7.28	6 x 0.71	4.72	4.33	1.18	4.49	1.57	1.26
4	KF 100-41	1190439-041	IR 100-10	1190409-010	1190045	3.85	8.98	6.68	8 x 0.71	5.67	5.24	1.18	5.31	1.77	1.26
5	KF 125-9	1190450-009	IR 125-6	1190410-006	1190026	4.72	9.84	8.46	8 x 0.71	6.89	6.50	1.38	6.69	1.97	1.50
6	KF 150-19	1190451-019	IR 150-10	1190411-010	1190047	5.63	12.00	10.23	8 x 0.87	8.07	7.87	1.57	8.03	1.97	1.77

Gasket for flange connections B2 and C (to ANSI)

DN	Gasket for Connection B2, C
1	3512265-700
1 1/4	3512266-700
1 1/2	3512267-700
2	3512268-700
2 1/2	3512269-700
3 1/2	3512270-700
4	3512271-700
5	3512272-700
6	3512273-700

Journal Flange Connection with O-Ring

For mounting rotary joints without alignment for high speeds we recommend to use O-rings for sealing.

Attention! Consider medium and temperature when selecting the O-ring!

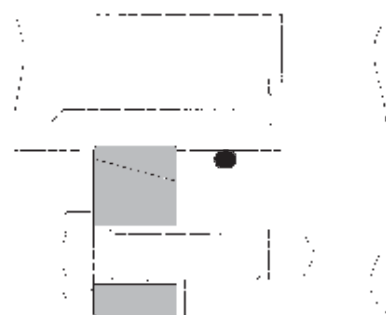

Attention: DN = DN of rotary joint.

Spare parts for series DQ DN 1"-1 1/2" (25-40 mm)

QCB 2... K

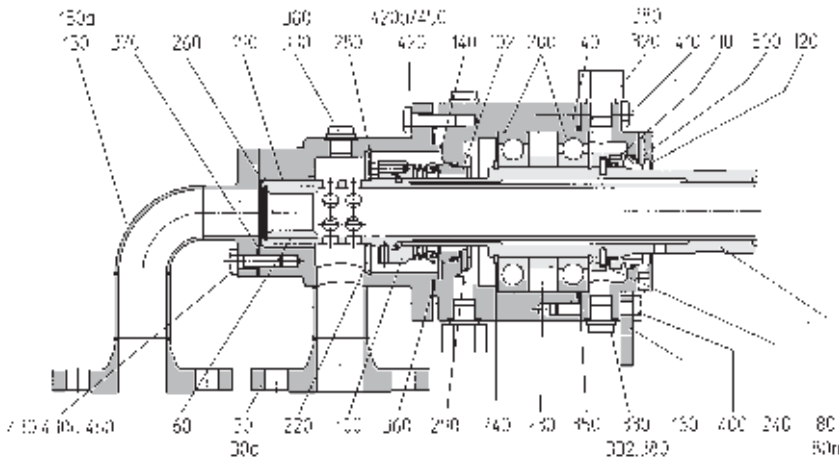

QCB 2... K

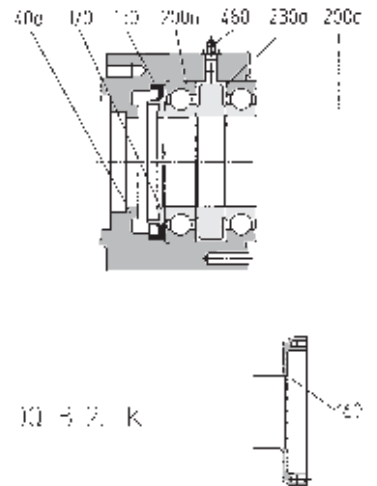

DN	1	1 1/4	1 1/2	
30	Housing DQB2 / DQLB2	-	-	-
30 a	Housing DQTB2	-	-	-
40	Bearing hous. DQ / DQT	1110184-145	1110184-145	1110259
40 a	Bearing housing DQL	1110184-150	1110184-150	1110259-122
60	Rotor bushing	1110119	1110194	1110269
80	Rotor K DQB2 / DQLB2	1110115	1110190-146	1110265
80 a	Rotor K DQTB2	1110115-072	1110190-157	1110265-116
100	Metal bellows primary seal	3511188-011	3511188-011	3511190-011
102	Counter face primary seal	1110202-133	1110202-133	1110277-101
110	Secondary seal compl.	1110201-141	1110201-141	1110276
110-10	Counter face secondary seal	3511404-077	3511404-077	3511405-046
110-20	Carbon sealing ring sec. seal	1110201-139	1110201-139	1110278
110-40	Compression spring	3511681	3511681	3511682
110-50	O-Ring 1	3511701-001	3511701-001	3511894-001
110-60	O-Ring 2	3511696-001	3511696-001	3511708-001
120	Cover	1110210-092	1110210-092	1110285-086
130	Shaft seal DQL	3511781-001	3511781-001	3511782-001
140	Support disk	1110206	1110206	1110281-057
150	Elbow DQ / DQL	-	-	-
150 a	Elbow DQT	-	-	-
160	Deflector sleeve DQT	1110209	1110209	1110295-123
170	Shaft sleeve DQL	1110223-154	1110223-154	1110298
180	Anti-rotation fork	1110212-066	1110212-066	1110287
190	Slide bush	3510482	3210482	3510532
200	Grooved ball bearing	3510135-005	3510135-005	3510206-005
200 a	Grooved ball bearing DQL	3510135-010	3510135-010	3510206-010
220	Seal protector disk	1110174	1110174	1110282-058

DN	1	1 1/4	1 1/2	
230	Distance ring DQ / DQT	1110208	1110208	1110283
230 a	Distance ring DQL	1110208-151	1110208-151	1110283-082
240	Circlip 1	3501023	3501023	3501024
260	Circlip 2	3501239	3500697	3501225
280	Retaining ring	3500696	3500696	3500706
290	Locking pin 1	3500886	3500886	3500904-004
300	Locking pin 2	3500890	3500890	3500890
320	Reducer fitting DQ /DQT	3513354	3513354	3513354
330	Screw plug 1	3500658	3500658	3500658
332	Sensor plug	3500658-063	3500658-063	3500658-063
350	O-Ring	3511871-001	3511871-001	3511719-001
360	Gasket 1	1110143-050	1110143-050	3512013
370	Gasket 2	3512012	3512012	3212014
380	CU-seal 1	3502116-001	3502116-001	3502116-001
400	Hexagon screw 1	3500053-007	3500053-007	3500128-007
410	Hexagon screw 2	3500052-007	3500052-007	3500127-007
420	Hex. screw 3 DQ / DQL	3500085-007	3500085-007	3500123-007
420 a	Stud bolt 1 DQT	3500275	3500275	3500232
430	Hex. screw 4 DQ / DQL	3500084-007	3500084-007	3500123-007
430 a	Stud bolt 2 DQT	3500275	3500275	3500232
450	Hexagon nut 1 DQT	3500301	3500301	3500303
460	Hexagon nut 2 DQT	3500301	3500301	3500303
480	Con. grease nipple DQL	3500914	3500914	3500914

Please specify exact designation when placing an inquiry or an order!
Maintenance in accordance with our instructions.

Spare parts for series DQ

DN 2"-6" (50-150 mm)

	DN	2	2 1/2	3 1/2	4	5	6
30	Housing B2	-	-	-	-	-	-
40	Bearing housing DQ / DQT	1110334-137	1110409-141	1110484-210	1110559-135	1110634	1110709
40 a	Bearing housing DQL	1110334-151	1110409-145	1110484-224	1110559-159	1110634-160	1110709-146
60	Rotor bushing	1110344-080	1110419	1110494-140	1110569-109	1110644	1110719
80	Rotor K DQB2 / DQLB2	1110340-138	1110415-108	1110490-214	1110565-136	1110640-132	1110715
80 a	Rotor K DQT B2	1110340-141	1110415-159	1110490-232	1110565-166	1110640-165	1110715-171
100	Metal bellows primary seal	3511191-011	3511192-011	3511193-011	3511194-011	3511195-011	3511196-011
102	Counter face primary seal	1110352-119	1110399-102	1110502-198	1110549-130	1110652-113	1110727-126
110	Secondary seal compl.	1110351	1110426	1110501	1110576	1110651	1110726
110-10	Counter face secondary seal	3511406-043	3511407-049	3511408-077	3511409-043	3511410-043	3511411-041
110-20	Carbon sealing ring sec. seal	1110353	1110399-092	1110503-111	1110578	1110653	1110728-153
110-40	Compression spring	3511683	3511685	8 x 3511553	8 x 3511550	8 x 3511551	8 x 3511551
110-50	O-Ring 1	3511871-001	3511716-001	3511873-001	3511703-001	3511725-001	3511727-004
110-60	O-Ring 2	3511869-001	3511715-001	3511874-001	3511702-001	3511712-001	3511726-004
120	Cover	1110360	1110435-144	1110510-212	1110585-145	1110660-125	1110735
130	Shaft seal DQL	3511180-001	3511953	3511972	3511178-001	3511181-001	3511165
140	Support disk	1110356-144	1110431-120	1110506-219	1110581-150	1110656-059	1110731-054
150	Elbow	-	-	-	-	-	-
160	Deflector sleeve DQT	1110348-146	1110423	1110522-231	1110597-149	1110648	1110723
170	Shaft sleeve DQL	1110373-145	1110448-134	1110523-222	1110598-139	1110673-139	1110729
180	Anti-rotation fork	1110362-083	1110437-115	1110512-220	1110587-146	1110662-140	1110737
190	Slide bush	3510523	3510539	3510513	3510519	3510485	3510491
200	Tapered roller bearing 1	3510142	3510044	3510027	3510025	3510072	3510024
202	Tapered roller bearing 2	3510045	3510044	3510027	3510021	3510072	3510023
204	Distance ring DQ,DQT	1110358-147	1110433-113	1110508-217	1110583-144	1110658-136	1110733
204 a	Distance ring DQL	1110358-148	1110433-132	1110508-225	1110583-162	1110658-162	1110733-140
206	Spacer	1110359-136	1110436	1110509-218	1110586-143	1110661	1110736
206 a	Spacer DQL	1110359-152	1110436-135	1110509-226	1110586-169	1110661-168	1110736
220	Seal protector disk	1110357-149	1110432-065	1110507-180	1110582-151	1110657-061	1110732-056
230	NILOS ring DQL	3509060	3509076	3509075	3509062	3509058	1110738
240	Grooved nut DQ / DQT	3513513	3513512	3513508	3513505	1110624-137	1110699-138
240 a	Grooved nut DQL	1110324-150	1110399-133	1110474-223	1110549-160	1110624-137	1110699-138
250	Circlip 1 DQL	3500930	3500950	3501037	3500949	3500959	3500954
260	Circlip 2	3501232	3501236	3501205	3501251	3501207	3501237
270	Compr.spring f. bearings	3511525	3511558	3511560	3511558	3511587	3511557
280	Retaining ring	3500870	3500874	3500693	3501050	3500709	3500871
290	Locking pin 1	3500909-004	3500909-004	3500890	3500922	3500922	3500896
300	Locking pin 2	3500909-004	3500909-004	3500922	3500922	3500922	3500922
310	Locking pin 3	3500940	3500940	3500940	3500940	3500940	3500940
320	Screw plug G ¹ / ₈	3500664	3500664	3500664	3500664	3500664	3500664
330	Screw plug G ¹ / ₂	3500655	3500655	3500655	3500655	3500655	3500655
332	Sensor plug	3500655-158	3500655-158	3500655-158	3500655-158	3500655-158	3500655-158
340	O-ring DQL	3511701-001	3511569-001	3511871-001	3511776-004	3511780-004	3511758-001
350	O-ring DQ / DQT	3511755-001	3511839-001	3511758-001	3511773-001	3511757-001	3511759-001
360	Gasket 1	1110444-062	3512018	1110594-070	1110669-063	1110668-084	1110743-116
370	Gasket 2	3512281	1103449-261	1110519-154	3512018	3512020	3512255
380	CU-seal	3502115-001	3502115-001	3502115-001	3502115-001	3502115-001	3502115-001
390	Circlip DQT	3500873	3500948	3500692	3500947	3500699	3500875
400	Hexagon screw 1	3500137-007	3500094-007	3500134-007	3500137-007	3500137-007	3500173-007
410	Hexagon screw 2	3500134-007	3500092-007	3500128-007	3500128-007	3500134-007	3500164-007

DN	2	2 1/2	3 1/2	4	5	6
420 Stud bolt or hexagon screw	3500123-007	3500164-007	3500274-007	3500271-007	3500271-007	3500271-007
420 a Stud bolt 1 DQT	3500257	3500279	3500986	3500242-007	3500242-007	3500242-007
430 Hexagon screw 3	3500123-007	3500123-007	3500165-007	3500161-007	3500166-007	3500204-007
430 a Stud bolt 2 DQT	3500257	3500257	3500227-007	3500234	3500234	3500236
450 Hexagon nut	-	-	3500285-007	3500287-007	3500287-007	3500287-007
450 a Hexagon nut DQT	3500303	3500285-001	3500285-001	3500300	3500300	3500300
460 Hexagon nut DQT	3500303	3500303	3500285-001	3500285-001	3500285-001	3500300
470 Eye screw	3500668	3500668	3500668	3500668	3500668	3500668
480 Conical grease nipple	3500914	3500914	3500914	3500914	3500914	3500914

Please specify exact type designation when placing an inquiry or an order!
Maintenance in accordance with our instructions.

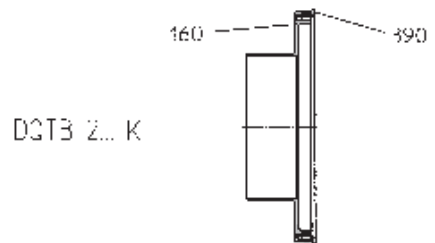
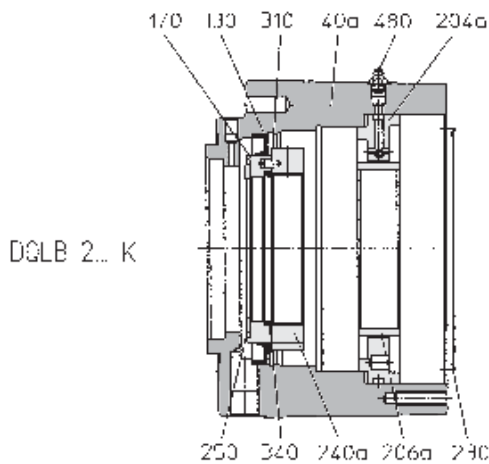
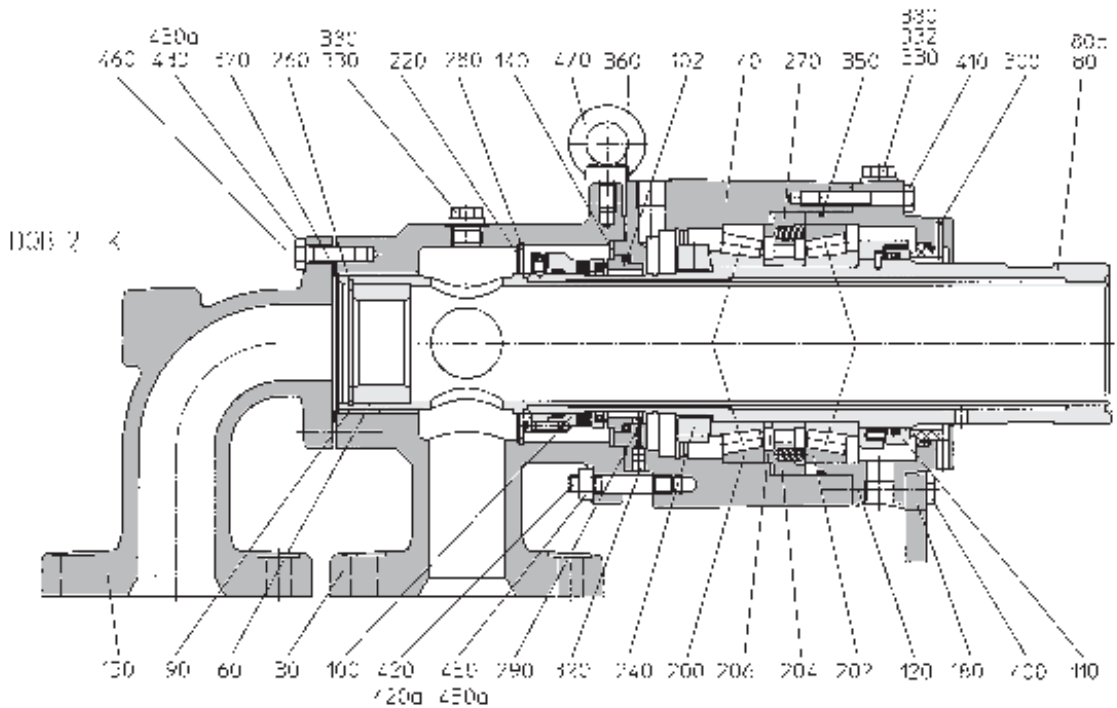

**Christian Maier GmbH & Co. KG
Maschinenfabrik**

Wuerzburger Straße 67-69
D-89520 Heidenheim

P.O.Box 1609
D-89506 Heidenheim

☎ + 49 (0) 73 21 / 317-0

✉ + 49 (0) 73 21 / 317-139 (Export)

☎ 0 800 / 7 51 82 50

✉ + 49 (0) 73 21 / 317-239

vkd@maier-heidenheim.de
www.maier-heidenheim.de

Branch Offices & Service Centers:

Maier America LLC

6649 Peachtree Industrial Blvd., Suite O
Norcross, GA 30092 - USA

☎ 770-409 0022

✉ 770-409 0069

info@maieramerica.com

www.maieramerica.com

Maier Italia Srl

Via Enrico Toti 3
I-21040 Gerenzano (VA)

☎ + 39-02-96 24 82 88

✉ + 39-02-96 36 96 95

info@maier-italia.com

www.maier-italia.com

