

Rotary Joints

Series H – US Catalog

NPT Threads

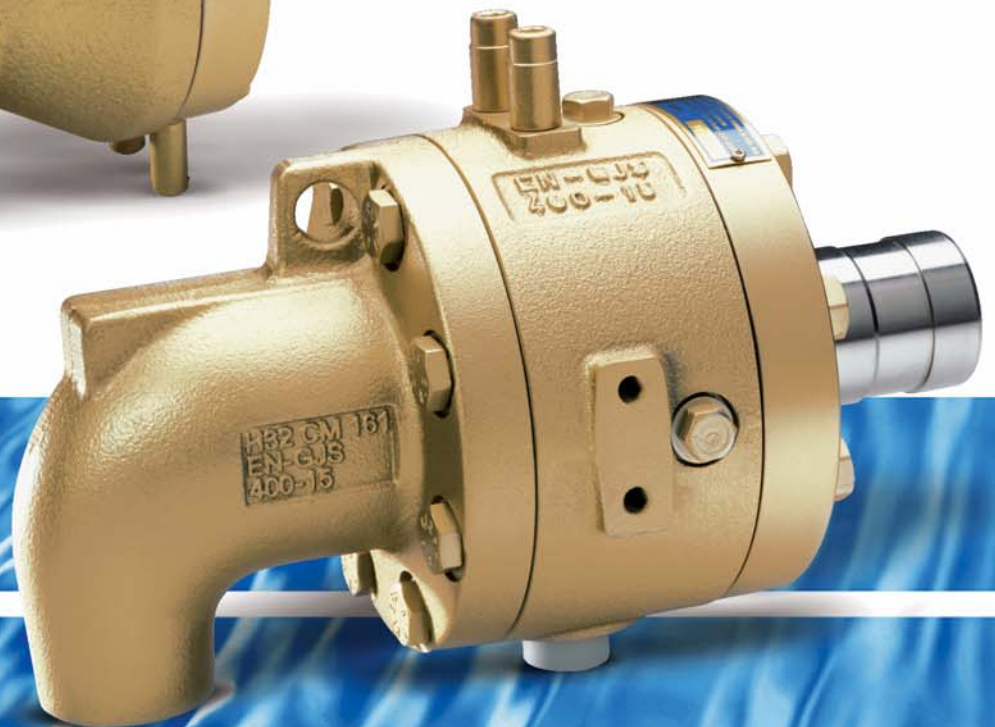

Rotary Joints Series H

Standard series H and HW are designed up to Nominal Diameter 4" (100 mm) to accommodate transfer of water, steam and thermal oil under temperature, rotation and pressure.

The fortified designs HWA, HWB, HWX are designed for higher speeds, higher loads and bigger sizes.

A flexible modular system with housing flange and gasket connections, which can be subsequently modified.

Operating manuals are available at www.maieramerica.com or directly from our company. Our sales staff will be happy to provide you with user identification and password. After placing an order you will find this information on the packing list.



Standard Series

- Housing made of ductile cast iron, cover and rotor made of chrome steel, rotors for Nominal Diameter 2 1/2" (65 mm) and above made of carbon steel, sealing face made of stainless steel. High temperature resistant spring made of stainless steel.
- Sealing ring of compression-loaded wear-resistant graphite carbon. Due to its design, it is shatter-proof under high pressure. Series HW with metal impregnated graphite carbon, is especially suitable for thermal oil and for considerably higher pressures, temperatures and speeds. The bearing is secured against rotation. Slide bushing is used as gap seal for rotating inner pipe. There is a wear indicator for the sealing ring at the rotor.
- Easy to repair. Maintenance-free, no relubrication.
- Connection to rotating pressurized system by means of:
 - Standardized connecting piece with right-hand or left-hand male thread NPT. BSP threads (ISO228) available - see European catalog D14507e.
 - K flange with conical inner ring – quick disconnect (must be ordered separately).
- Radial and axial housing connection with right hand NPT thread as well as with flange connections available.

We recommend using flange connections for thermal oil.
Screw thread for fixed inner pipe is always right handed, even when thread on rotor is left handed.
- Rotation of the housing is prevented by means of the anti-rotating fork on the cover, where the locking bolt engages. Thermal expansion of the roller and wear of seals and bearing cause an axial displacement of the housing (away from the roller). Anti-rotation device, hose connection and inner pipe must not impede this axial displacement. Otherwise the rotary joint will not operate or seal properly.

The fortified designs HWA, HWB, HWX are

- More robust
 - Greater distance between bearings, double-sized cover bushing, two large bearings from Nominal Diameter 3" (75 mm) and above.
 - Anti-rotation device between the bearings ensures low moment of friction.
 - Housing flange connection is sealed with a gasket, no soldering.
- Faster
 - Up to 50 % higher speed possible than standard series.
- More flexible
 - Modular system: please specify required position when placing the order.
 - Housing flanges can be screwed in later.



The fortified designs are equipped as follows:

- Housing of ductile cast iron, HWA Nominal Diameter 4" (100 mm) and above is made of carbon steel in welded design.
 - Rotor of stainless steel 316 Ti (1.4571) or PVD coated steel. All other steel parts in stainless steel.
 - Metal-impregnated sealing ring, suitable for high pressure.
 - Housing bearing secured against rotation.
 - Connection to the rotating pressurized system by means of K-flange and conical inner ring (quick disconnect).
 - Radial and axial housing connections with right-hand thread NPT. As an option, Nominal Diameter 1 1/4" - 4" (32-100 mm) with screw flange and gasket, ANSI 300 lbs; Nominal Diameter 4" - 12" (100-300 mm) with welded flanges ANSI 300 lbs. For Nominal Diameter 1/2" - 1" (15-25 mm), we offer flexible metal hoses sealed with a gasket, since housing flanges would be too heavy for this purpose. Rotation of the housing is prevented by means of the anti-rotating fork at the housing.
 - From Nominal Diameter 4" (100 mm and above), the unit weight is to be partially supported by means of the housing lug, where the locking bolt engages.
 - There are numerous designs available:
 - HW1 -780 and HWA, B, X2 -780. Based on standard basic design (HW 1) and on fortified design (HWA, B, X), however suitable for higher loads with rotors made of stainless steel 316 Ti (1.4571) or PVD coated steel, with screw flanges, sealed with gasket, ANSI 300 lbs.
 - HWX for stationary inner pipe, right-hand thread.
 - HWB for rotating inner pipe, bearing bush rotating with rotor, no wear. Gap seal, suitable for liquids, low pressure loss between flow and return.
 - HWA for rotating inner pipe, bearing bush rotating with rotor, no wear. Carbon bearing with steel jacket, sealed against housing via O-ring. Rotor bushing sealed against inner pipe via O-ring. Suitable for steam and high pressure difference between inlet and outlet.
- HWA for big Nominal Diameter > 4" (100 mm) in welded design.

Application data

Series		H	HW	HW		
Design Nominal diameter in inch		2, R2, 3 1/2...4	2, R2, 3 1/2...4	X2, A2 1 1/4...4		
Medium		Water Steam	Thermal oil	Water Steam	Thermal oil	Water
Temperature	min...max °F	14...428	14...572	14...446	14...572	14...446
Pressure	PN min...max psi	12...290	12...145	12...406	12...145	12...406
Speed	max. min ⁻¹	$\frac{28.200}{(DN \times PN)}$	$\frac{56.400}{(DN \times PN)}$	$\frac{56.400}{(DN \times PN)}$	$\frac{56.400}{(DN \times PN)}$	$\frac{84.600}{(DN \times PN)}$

Overspeed limitation

nominal diameters DN in inch		1/2	3/4	1	1 1/4
Speed	max. min ⁻¹	470	440	425	390

*For DN 8" + 12" max. 392° F, 232 psi. Series H3 with vacuum breaker. Designs for higher values and media upon request. The combination of maximum values should be avoided.

Ordering instructions

Example:

H W X 2 32 K -780

H	Series
W	High-performance sealing ring, metal-impregnated
X	Design for
R	stationary inner pipe
B	rotating inner pipe with slide bushing and gap seal in the housing
A	rotating inner pipe with gap seal between flow and return
	rotating inner pipe with complete sealing between flow and return
	Number of housing connections
1	for one way flow design
2	for two way flow design
3	for two way flow design with vacuum breaker
	Nominal diameter (≙ dimension A)
	1/2, 3/4, 1, 1 1/4, 1 1/2, 2, 2 1/2, 3, 3 1/2, 4, 5, 6, 8, 12 inch
	15, 20, 25, 32, 40, 50, 65, 75, 80, 100, 125, 150, 200, 300 mm
	Rotor connection
R	for right-hand thread
L	for left-hand thread
K	for K flange
	Adapters for other threads are available, upon request.
	Consecutive numbers for special designs; numbering by factory.
	Exceptions: variant -780 with slip flanges.

HW	HW -760		HW -760		HW	
B2 1 1/4...4	X2, A2 1 1/4...4		B2 1 1/4...4		1 5...12 A2 4...12	
Thermal oil	Water Steam	Thermal oil	Water Steam	Thermal oil	Water Steam	Thermal oil
14...572 12...145	14...446 12...406	14...572 12...145	14...446 12...406	14...572 12...145	14...410* 12...290*	14...572 12...145
$\frac{84.600}{(DN \times PN)}$	$\frac{56.400}{(DN \times PN)}$	$\frac{56.400}{(DN \times PN)}$	$\frac{56.400}{(DN \times PN)}$	$\frac{56.400}{(DN \times PN)}$	$\frac{84.600}{(DN \times PN)}$	$\frac{84.600}{(DN \times PN)}$

1 1/2	2	2 1/2	3	3 1/2	4	5	6	8	10
370	325	265	250	250	180	100	80	60	30

Assembly by modular system for HWX – HWB – HWA DN 1 1/4 - 4

When placing the order, please copy this page, fill in the blanks and send it by fax to + 1-770-409 0069 or as PDF file to info@maieramerica.com

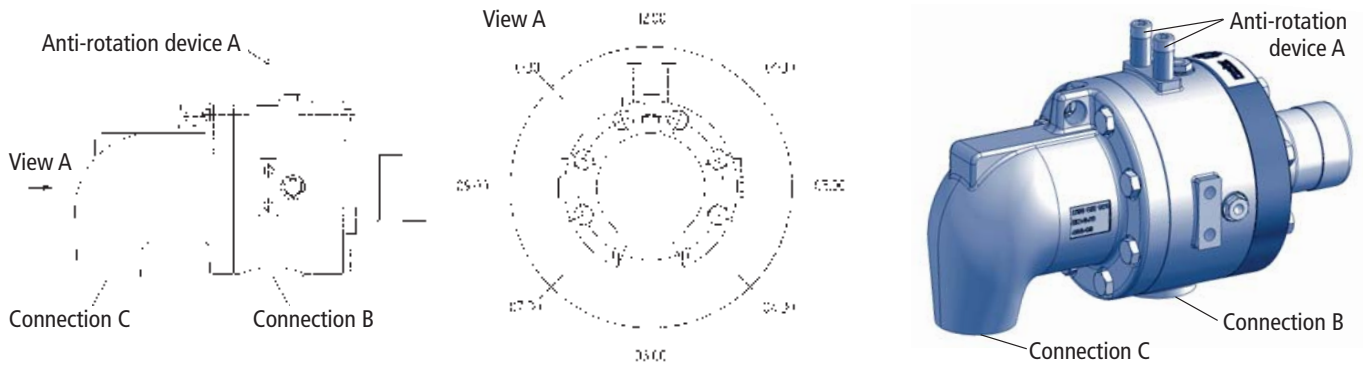

Customer

Order number

Connection B	Anti-rotation device A	Connection C
06:00	03:00	01:30
	09:00	03:00
	12:00	04:30
		06:00
		07:30
		09:00
		10:30
		12:00

Orientation of connection B always in 6 o'clock position. Line of sight to the rotary joint: view A (from the rear).

Please check required positions of anti-rotation device A and connection C. The ordered rotary joint will be assembled according to these instructions.

H2 + HW2 DN 1/2 - 4

for two way flow of a medium designed for non-rotating inner pipe
for mono flow operation C port is plugged

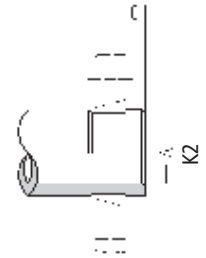
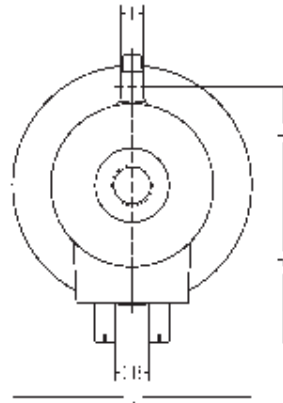
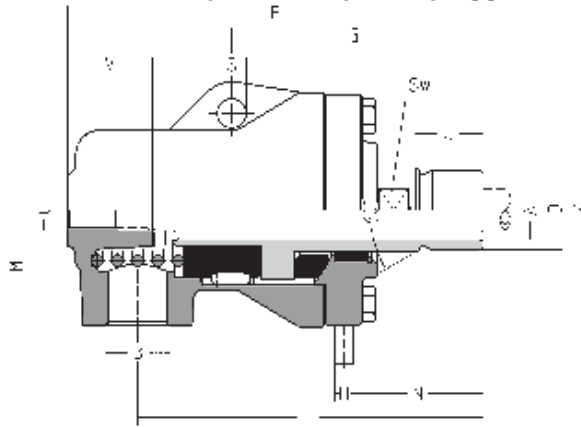

Flanges see page 16

DN	1/4	3/4	1	1 1/4	1 1/2	2	2 1/2	3 1/2	4	
H	Type	H 215 R-700	H 220 R-700	H 225 R-700	H 232 R-700	H 240 R-700	H 250 R-700	H 265 R-700	H 280 R-700	H 2100 R-700
	Order-No.	1108053-700	1108133-700	1108213-700	1108353-700	1108453-700	1108553-700	1108654-700	1108753-700	1108853-700
H	Type	H 215 L-700	H 220 L-700	H 225 L-700	H 232 L-700	H 240 L-700	H 250 L-700	H 265 L-700	H 280 L-700	H 2100 L-700
	Order-No.	1108054-700	1108134-700	1108214-700	1108354-700	1108454-700	1108554-700	1108655-700	1108754-700	1108854-700
H	Type	H 215 K-700	H 220 K-700	H 225 K-700	H 232 K-700	H 240 K-700	H 250 K-700	H 265 K-700	H 280 K-700	H 2100 K-700
	Order-No.	1108055-700	1108135-700	1108215-700	1108355-700	1108455-700	1108555-700	1108656-700	1108755-700	1108855-700
HW	Type	HW 215 R-700	HW 220 R-700	HW 225 R-700	HW 232 R-700	HW 240 R-700	HW 250 R-700	HW 265 R-700	HW 280 R-700	HW 2100 R-700
	Order-No.	1108068-700	1108148-700	1108167-700	1108363-700	1108468-700	1108568-700	1108668-700	1108768-700	1108868-700
HW	Type	HW 215 L-700	HW 220 L-700	HW 225 L-700	HW 232 L-700	HW 240 L-700	HW 250 L-700	HW 265 L-700	HW 280 L-700	HW 2100 L-700
	Order-No.	1108069-700	1108149-700	1108168-700	1108364-700	1108469-700	1108569-700	1108669-700	1108769-700	1108869-700
HW	Type	HW 215 K-700	HW 220 K-700	HW 225 K-700	HW 232 K-700	HW 240 K-700	HW 250 K-700	HW 265 K-700	HW 280 K-700	HW 2100 K-700
	Order-No.	1108070-700	1108150-700	1108170-700	1108365-700	1108470-700	1108570-700	1108670-700	1108770-700	1108870-700

Ø A	0.512	0.728	0.945	1.26	1.457	1.89	2.362	3.189	3.858
B (NPT)	1/2	3/4	1	1 1/4	1 1/2	2	2 1/2	3	4
C (NPSC)	1/8	1/4	3/8	1/2	3/4	1	1 1/4	1 1/2	2
D (NPT)	1/2	3/4	1	1 1/4	1 1/2	2	2 1/2	3 1/2	4
E	5.315	6.024	7.047	8.071	9.055	10.709	12.756	15.472	18.701
F	4.488	5.079	5.906	6.772	7.48	8.858	10.394	12.598	15.079
G	3.622	3.937	4.37	4.843	5.157	5.748	6.496	7.992	9.567
GB	0.472	0.472	0.551	0.63	0.63	0.709	0.787	0.866	1.024
H	0.276	0.315	0.315	0.394	0.433	0.512	0.709	0.709	0.984
Ø J	3.15	3.465	3.819	4.488	4.882	5.669	7.165	8.661	10.236
Ø K	0.984	1.181	1.378	1.772	2.047	2.598	3.346	4.213	4.646
Ø K 2	0.807/0.809	1.017/1.019	1.269/1.272	1.612/1.614	1.870/1.872	2.320/2.322	2.836/2.838	3.931/3.933	4.427/4.429
L	1.22	1.417	1.575	1.89	2.087	2.441	3.15	3.937	4.528
M	1.339	1.654	1.89	2.165	2.559	3.15	3.543	4.528	5.315
N	2.047	2.244	2.362	2.638	2.874	3.228	3.661	4.764	5.63
O	0.374	0.437	0.437	0.5	0.5	0.626	0.748	1	1
R	1.811	1.969	2.126	2.559	2.756	3.189	3.976	4.764	5.630
S	0.472	0.472	0.551	0.630	0.630	0.709	0.787	0.866	1.024
T	0.276	0.315	0.354	0.394	0.472	0.512	0.591	0.787	0.866
U *	0.906	0.906	1.102	1.299	1.417	1.693	1.890	2.126	2.598
V	1.102	1.260	1.378	1.772	1.969	2.362	2.756	3.150	3.543
SW	0.866	1.063	1.181	1.614	1.811	2.362	2.953	3.740	4.331
Z1 *	4.429	5.075	5.992	6.728	7.531	8.878	10.551	12.874	15.724
Weight (lbs)	3.5	5.1	7.1	11.7	15.2	24.5	46.9	81.8	134.5

* approx. engagement depth (wrench tight)

HR2 + HWR2 DN 1/2 - 4

for two way flow of a medium designed for rotating inner pipe

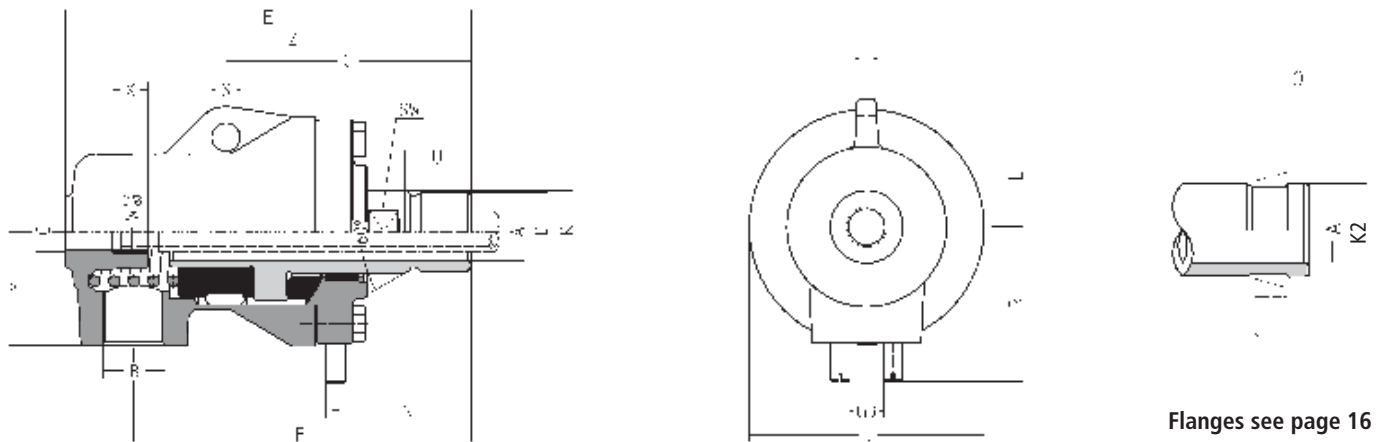

Flanges see page 16

DN	1/2	3/4	1	1 1/4	1 1/2	2	2 1/2	3 1/2	4
Type	HR 215 R-700	HR 220 R-700	HR 225 R-700	HR 232 R-700	HR 240 R-700	HR 250 R-700	HR 265 R-700	HR 280 R-700	HR 2100 R-700
Order-No.	1108056-700	1108136-700	1108219-700	1108359-700	1108459-700	1108556-700	1108657-700	1108756-700	1108856-700
Type	HR 215 L-700	HR 220 L-700	HR 225 L-700	HR 232 L-700	HR 240 L-700	HR 250 L-700	HR 265 L-700	HR 280 L-700	HR 2100 L-700
Order-No.	1108057-700	1108137-700	1108220-700	1108360-700	1108460-700	1108557-700	1108658-700	1108757-700	1108857-700
Type	HR 215 K-700	HR 220 K-700	HR 225 K-700	HR 232 K-700	HR 240 K-700	HR 250 K-700	HR 265 K-700	HR 280 K-700	HR 2100 K-700
Order-No.	1108058-700	1108138-700	1108224-700	1108375-700	1108463-700	1108560-700	1108659-700	1108761-700	1108861-700
Type	HWR 215 R-700	HWR 220 R-700	HWR 225 R-700	HWR 232 R-700	HWR 240 R-700	HWR 250 R-700	HWR 265 R-700	HWR 280 R-700	HWR 2100 R-700
Order-No.	1108071-700	1108151-700	1108171-700	1108369-700	1108471-700	1108571-700	1108671-700	1108771-700	1108871-700
Type	HWR 215 L-700	HWR 220 L-700	HWR 225 L-700	HWR 232 L-700	HWR 240 L-700	HWR 250 L-700	HWR 265 L-700	HWR 280 L-700	HWR 2100 L-700
Order-No.	1108072-700	1108152-700	1108172-700	1108370-700	1108472-700	1108572-700	1108672-700	1108772-700	1108872-700
Type	HWR 215 K-700	HWR 220 K-700	HWR 225 K-700	HWR 232 K-700	HWR 240 K-700	HWR 250 K-700	HWR 265 K-700	HWR 280 K-700	HWR 2100 K-700
Order-No.	1108073-700	1108153-700	1108176-700	1108376-700	1108476-700	1108573-700	1108673-700	1108773-700	1108873-700

Ø A	0.512	0.728	0.945	1.26	1.457	1.89	2.362	3.189	3.858
B (NPT)	1/2	3/4	1	1 1/4	1 1/2	2	2	3	4
C (NPSC)	1/8	1/4	3/8	1/2	3/4	1	1 1/4	1 1/2	2
D (NPT)	1/2	3/4	1	1 1/4	1 1/2	2	2 1/2	3 1/2	4
E	5.315	6.024	7.047	8.071	9.055	10.709	12.756	15.472	18.701
F	4.488	5.079	5.906	6.772	7.48	8.858	10.394	12.598	15.079
G	3.622	3.937	4.37	4.843	5.157	5.748	6.496	7.992	9.567
GB	0.472	0.472	0.551	0.63	0.63	0.709	0.787	0.866	1.024
H	0.276	0.315	0.315	0.394	0.433	0.512	0.709	0.709	0.984
Ø J	3.15	3.465	3.819	4.488	4.882	5.669	7.165	8.661	10.236
Ø K	0.984	1.181	1.378	1.772	2.047	2.598	3.346	4.213	4.646
Ø K 2	0.807/0.809	1.017/1.019	1.269/1.272	1.612/1.614	1.870/1.872	2.320/2.322	2.836/2.838	3.931/3.933	4.427/4.429
L	1.22	1.417	1.575	1.89	2.087	2.441	3.15	3.937	4.528
M	1.339	1.654	1.89	2.165	2.559	3.15	3.543	4.528	5.315
N	2.047	2.244	2.362	2.638	2.874	3.228	3.661	4.764	5.63
O	0.374	0.437	0.437	0.5	0.5	0.626	0.748	1	1
R	1.811	1.969	2.126	2.559	2.756	3.189	3.976	4.764	5.63
S	0.472	0.472	0.551	0.63	0.63	0.709	0.787	0.866	1.024
T	0.276	0.315	0.354	0.394	0.472	0.512	0.591	0.787	0.866
U *	0.427	0.446	1.53	0.55	0.55	0.567	0.807	0.946	0.969
Ø W	0.374/0.373	0.499/0.498	0.624/0.623	0.749/0.748	0.999/0.998	1.249/1.247	1.499/1.497	1.749/1.747	2.251/2.249
X	0.591	0.591	0.591	0.591	0.984	0.984	1.181	1.181	1.575
Z	4.606	5.079	5.984	6.693	7.795	9.331	11.181	13.504	16.732
SW	0.866	1.063	1.181	1.614	1.811	2.362	2.953	3.740	4.331
Weight (lbs)	3.5	5.1	7.1	11.7	15.2	24.5	46.9	81.8	134.5

* approx. engagement depth (wrench tight)

H3 DN 1 - 1 1/4

for two way flow of a medium designed for non-rotating inner pipe, with vacuum breaker

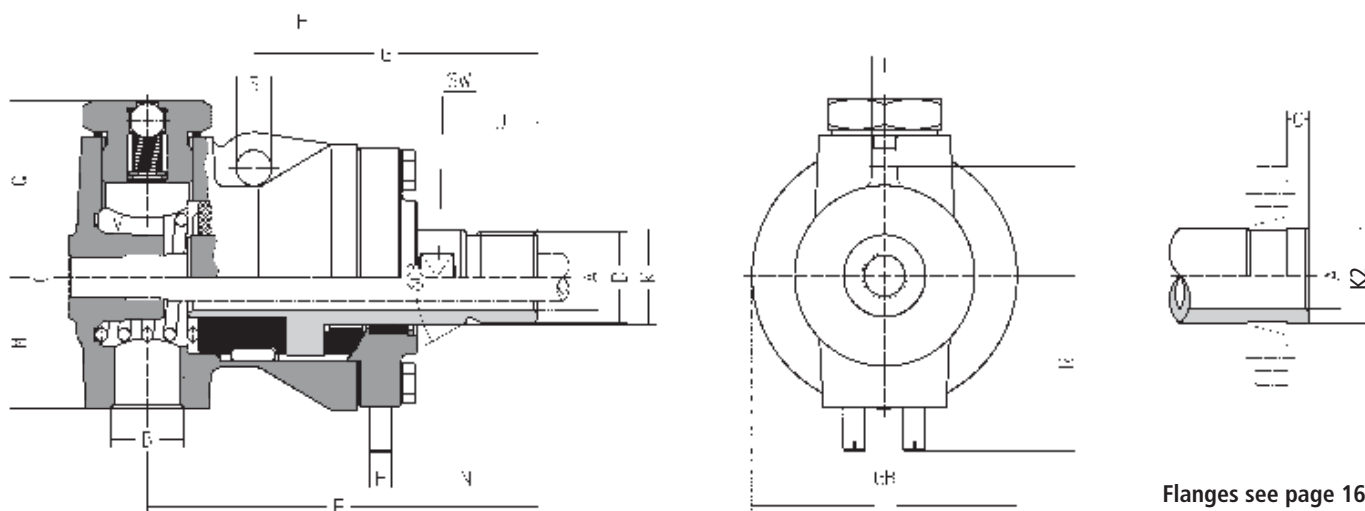

Flanges see page 16

DN	1	1 1/4
Type	H 325 R-700	H 332 R-700
Order-No.	1108216-700	1108356-700
Type	H 325 L-700	H 332 L-700
Order-No.	1108217-700	1108357-700
Type	H 325 K-700	H 332 K-700
Order-No.	1108218-700	1108358-700
Ø A	0.945	1.260
B (NPT)	3/4	1
C (NPSC)	3/8	1/2
D (NPT)	1	1 1/4
E	7.047	8.071
F	5.906	6.772
G	4.370	4.843
GB	0.551	0.630
H	0.315	0.394
Ø J	3.819	4.488
Ø K	1.378	1.772
Ø K2	1.269/1.272	1.612/1.614
L	1.575	1.890
M	1.890	2.165
N	2.362	2.638
O	0.437	0.500
Q	2.520	2.717
R	2.126	2.559
S	0.551	0.630
T	0.354	0.394
U *	0.530	0.550
V	1.378	1.772
Z1 *	5.992	6.728
SW	1.181	1.614
Weight (lbs)	7.9	12.6

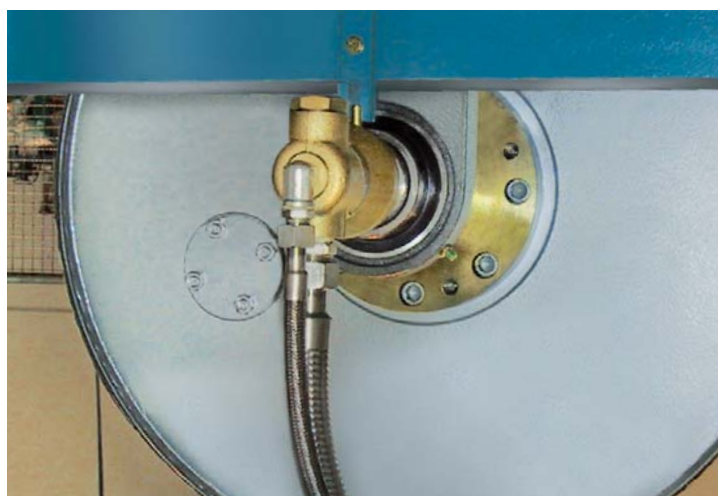

*approx. engagement depth (wrench tight)

HW1 DN 1 1/4 - 4 series -780

for one way flow of a medium

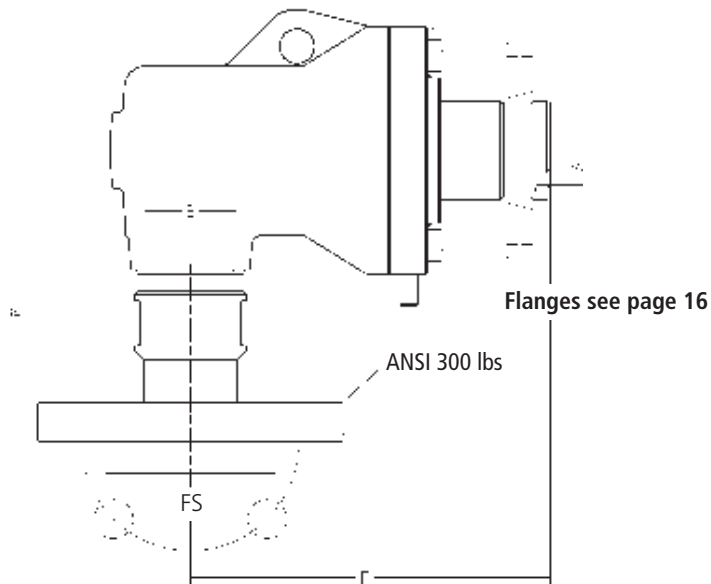

DN	1 1/4	1 1/2	2	2 1/2	3 1/2	4
Type	HW 132 K-780	HW 140 K-780	HW 150 K-780	HW 165 K-780	HW 180 K-780	HW 1100 K-780
Order-No.	1108368-780	1108467-780	1108567-780	1108667-780	1108767-780	1108867-780
Ø A	1.260	1.457	1.890	2.362	3.189	3.858
B	G 1 1/4	G 1 1/2	G 2	G 2 1/2	G 3	G 4
F	6.772	7.480	8.858	10.394	12.598	15.079
M	5.315	5.709	6.496	7.283	8.268	9.843
FS	1 1/4	1 1/2	2	2 1/2	3	4
Weight (lbs)	18.7	23.2	35.3	59.5	101.4	163.2

All other dimensions see page 6.

HWX2 DN 1 1/4 - 4

for two way flow of a medium designed for non-rotating inner pipe

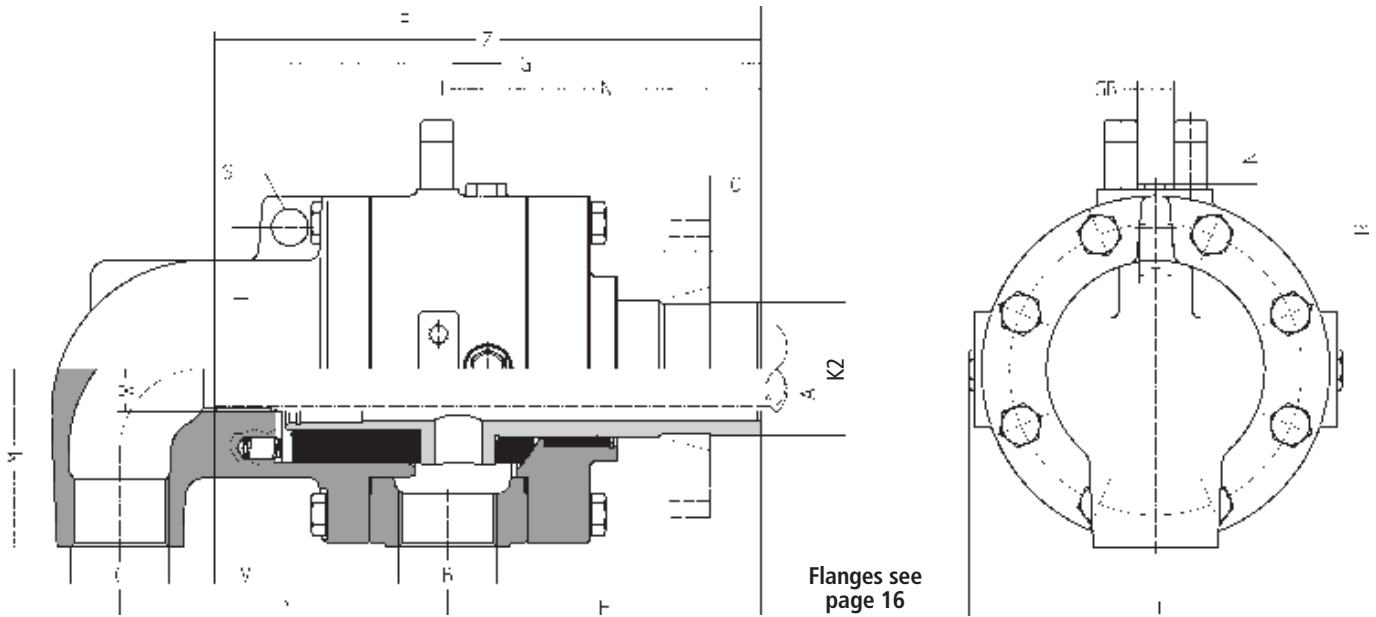

DN	1 1/4	1 1/2	2	2 1/2	3	3 1/2	4
Type	HWX 232 K-700	HWX 240 K-700	HWX 250 K-700	HWX 265 K-700	HWX 275 K-700	HWX 280 K-700	HWX 2100 K-700
Order-No.	1108385-700	1108485-700	1108585-700	1108685-700	1108705-700	1108785-700	1108885-700
Ø A	1.260	1.457	1.890	2.362	2.638	3.189	3.858
B (NPT)	1	1 1/4	1 1/2	2	2 1/2	2 1/2	3
C (NPT)	1	1 1/4	1 1/2	2	2 1/2	2 1/2	3
E	10.669	12.323	13.661	15.827	21.063	21.260	23.976
F	4.724	5.197	6.024	7.008	10.630	10.827	12.008
G	7.205	8.051	9.055	10.709	14.961	15.157	16.693
GB	0.630	0.630	0.709	0.787	0.866	0.866	1.024
H	0.531	0.630	0.630	0.709	0.709	0.709	0.984
J	5.906	6.260	7.126	8.583	10.787	10.787	11.890
Ø K2	1.612/1.614	1.870/1.872	2.320/2.322	2.836/2.838	3.434/3.437	3.931/3.933	4.427/4.429
L	2.165	2.283	2.717	3.346	4.173	4.173	4.724
M	2.756	2.953	3.425	4.055	5.118	5.118	5.709
N	4.646	5.079	5.906	7.047	10.512	10.709	11.772
O	0.500	0.500	0.626	0.748	1.181	1.000	1.000
P	4.921	5.945	6.299	7.087	8.268	8.268	9.449
R	3.858	4.331	4.764	5.669	6.772	6.772	7.638
Ø S	0.630	0.630	0.709	0.787	0.866	0.866	1.024
T	0.512	0.591	0.630	0.709	0.984	0.984	1.024
V	0.954	1.197	1.541	1.780	2.253	2.253	2.703
W (NPSC)	3/4	1	1 1/4	1 1/2	1 1/2	2	2 1/2
Z ± 0.15	8.08	9.071	10.871	12.686	17.646	17.843	20.105
NT	0.906	1.201	1.201	1.378	1.378	1.378	1.693
Weight (lbs)	26.5	36.4	48.5	81.6	160.9	160.9	202.9

HWB2 DN 1 1/4 - 4

for two way flow of a medium designed for rotating inner pipe

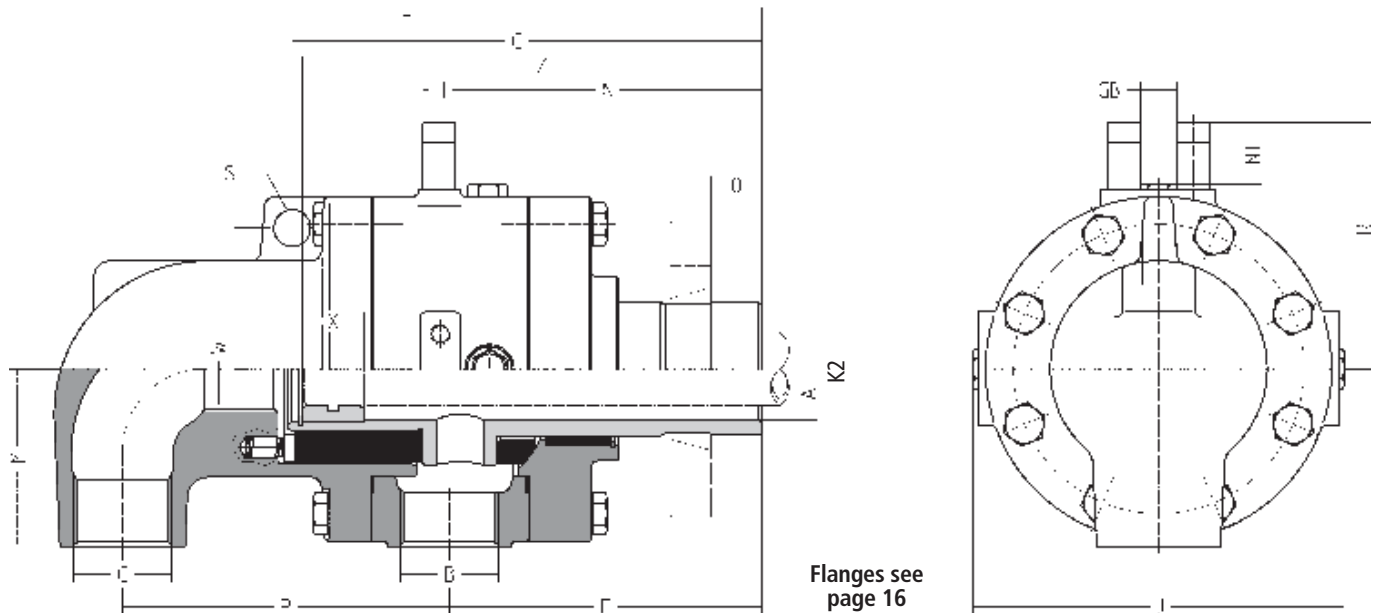

DN	1 1/4	1 1/2	2	2 1/2	3	3 1/2	4
Type	HWB 232 K-700	HWB 240 K-700	HWB 250 K-700	HWB 265 K-700	HWB 275 K-700	HWB 280 K-700	HWB 2100 K-700
Order-No.	1108402-700	1108482-700	1108577-700	1108677-700	1108702-700	1108778-700	1108902-700
Ø A	1.26	1.457	1.89	2.362	2.638	3.189	3.858
B (NPT)	1	1 1/4	1 1/2	2	2 1/2	2 1/2	3
C (NPT)	1	1 1/4	1 1/2	2	2 1/2	2 1/2	3
E	10.669	12.323	13.661	15.827	21.063	21.260	23.976
F	4.724	5.197	6.024	7.008	10.630	10.827	12.008
G	7.205	8.051	9.055	10.709	14.961	15.157	16.693
GB	0.630	0.630	0.709	0.787	0.866	0.866	1.024
H	0.531	0.630	0.630	0.709	0.709	0.709	0.984
J	5.906	6.260	7.126	8.583	10.787	10.787	11.890
Ø K2	1.612/1.614	1.870/1.872	2.320/2.322	2.836/2.838	3.434/3.437	3.931/3.933	4.427/4.429
L	2.165	2.283	2.717	3.346	4.173	4.173	4.724
M	2.756	2.953	3.425	4.055	5.118	5.118	5.709
N	4.646	5.079	5.906	7.047	10.512	10.709	11.772
O	0.500	0.500	0.626	0.748	1.181	1.000	1.181
P	4.921	5.945	6.299	7.087	8.268	8.268	9.449
R	3.858	4.331	4.764	5.669	6.772	6.772	7.638
Ø S	0.630	0.630	0.709	0.787	0.866	0.866	1.024
T	0.512	0.591	0.630	0.709	0.984	0.984	1.024
Ø W	1.002/1.004	1.252/1.254	1.502/1.504	1.752/1.754	1.752/1.754	2.252/2.254	2.753/2.755
X	1.181	1.181	1.181	1.575	1.575	1.575	1.969
Z	6.772	7.480	8.858	10.236	14.646	14.843	16.496
NT	0.906	1.201	1.201	1.378	1.378	1.378	1.693
Weight (lbs)	26.5	36.4	48.5	81.6	161	161	202.9

HWA2 DN 1 1/4 - 4

for two way flow of a medium designed for rotating inner pipe

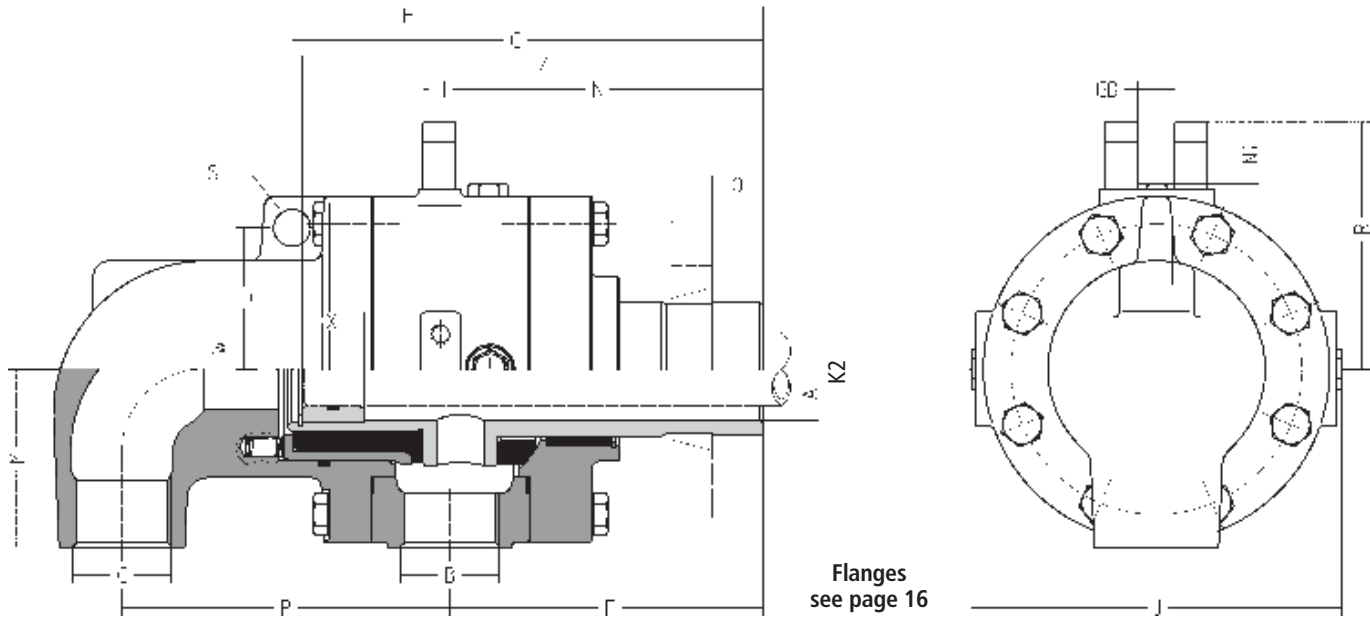

DN	1 1/4	1 1/2	2	2 1/2	3	3 1/2	4
Type	HWA 232 K-700	HWA 240 K-700	HWA 250 K-700	HWA 265 K-700	HWA 275 K-700	HWA 280 K-700	HWA 2099 K-700
Order-No.	1108390-700	1108490-700	1108590-700	1108690-700	1108710-700	1108790-700	1108880-700
Ø A	1.260	1.457	1.890	2.362	2.638	3.189	3.858
B (NPT)	1	1 1/4	1 1/2	2	2 1/2	2 1/2	3
C (NPT)	1	1 1/4	1 1/2	2	2 1/2	2 1/2	3
E	10.669	12.323	13.661	15.827	21.063	21.260	23.976
F	4.724	5.197	6.024	7.008	10.630	10.827	12.008
G	7.205	8.051	9.055	10.709	14.961	15.157	16.693
GB	0.630	0.630	0.709	0.787	0.866	0.866	1.024
H	0.531	0.630	0.630	0.709	0.709	0.709	0.984
J	5.906	6.260	7.126	8.583	10.787	10.787	11.890
Ø K2	1.612/1.614	1.870/1.872	2.320/2.322	2.836/2.838	3.434/3.437	3.931/3.933	4.427/4.429
L	2.165	2.283	2.717	3.346	4.173	4.173	4.724
M	2.756	2.953	3.425	4.055	5.118	5.118	5.709
N	4.646	5.079	5.906	7.047	10.512	10.709	11.772
O	0.500	0.500	0.626	0.748	1.181	1.000	1.000
P	4.921	5.945	6.299	7.087	8.268	8.268	9.449
R	3.858	4.331	4.764	5.669	6.772	6.772	7.638
Ø S	0.630	0.630	0.709	0.787	0.866	0.866	1.024
T	0.512	0.591	0.630	0.709	0.984	0.984	1.024
Ø W	1.002/1.004	1.252/1.254	1.502/1.504	1.752/1.754	1.752/1.754	2.252/2.254	2.753/2.755
X	1.181	1.181	1.181	1.575	1.575	1.575	1.969
Z	6.772	7.480	8.858	10.236	14.646	14.843	16.496
NT	0.906	1.201	1.201	1.378	1.378	1.378	1.693
Weight (lbs)	26.5	36.4	48.5	81.6	161	161	202.9

HWX2 + HWB2 + HWA2 DN 1 1/2 - 4 series -780

with flange connections

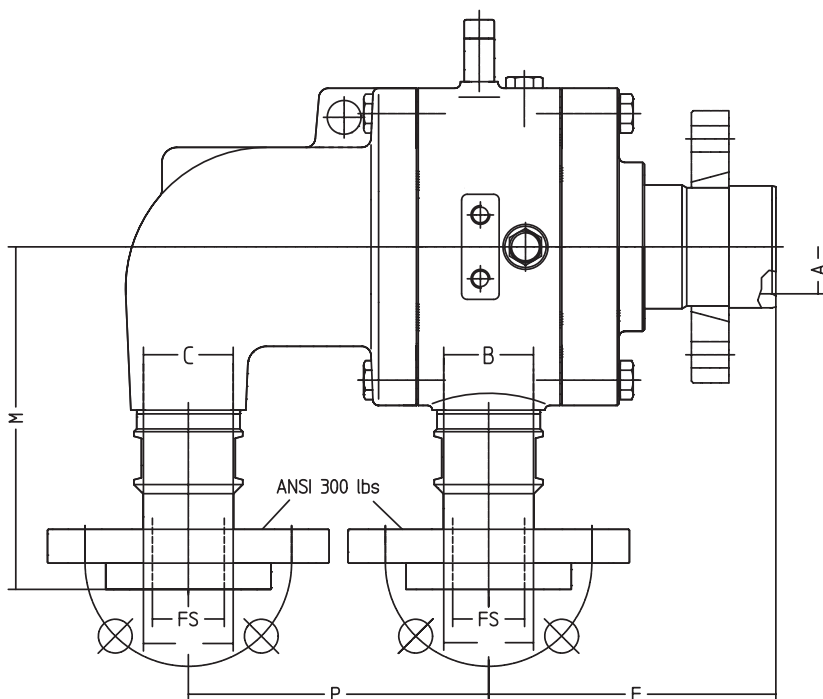

Flanges see page 16

DN	1 1/4	1 1/2	2	2 1/2	3	3 1/2	4
Type	HWX 232 K-780	HWX 240 K-780	HWX 250 K-780	HWX 265 K-780	HWX 275 K-780	HWX 280 K-780	HWX 2100 K-780
Order-No.	1108385-780	1108485-780	1108585-780	1108685-780	1108705-780	1108785-780	1108885-780
Type	HWB 232 K-780	HWB 240 K-780	HWB 250 K-780	HWB 265 K-780	HWB 275 K-780	HWB 280 K-780	HWB 2100 K-780
Order-No.	1108402-780	1108482-780	1108577-780	1108677-780	1108702-780	1108778-780	1108902-780
Type	HWA 232 K-780	HWA 240 K-780	HWA 250 K-780	HWA 265 K-780	HWA 275 K-780	HWA 280 K-780	HWA 2099 K-780
Order-No.	1108390-780	1108490-780	1108590-780	1108690-780	1108710-780	1108790-780	1108880-780
Ø A	1.260	1.457	1.890	2.362	2.638	3.189	3.858
B	BSP 1	BSP 1 1/4	BSP 1 1/2	BSP 2	BSP 2 1/2	BSP 2 1/2	BSP 3
C	BSP 1	BSP 1 1/4	BSP 1 1/2	BSP 2	BSP 2 1/2	BSP 2 1/2	BSP 3
F	4.724	5.197	6.024	7.008	10.630	10.827	12.008
M	6.358	6.634	7.185	7.953	9.173	9.173	10.610
P	4.921	5.945	6.299	7.087	8.268	8.268	9.449
FS	1	1 1/4	1 1/2	2	2 1/2	2 1/2	3
Weight (lbs)	35.3	48.5	63.9	102.5	186.3	186.3	235.9

All other dimensions see pages 10, 11 and 12.

HW1 DN 5 - 12

for one way flow of a medium

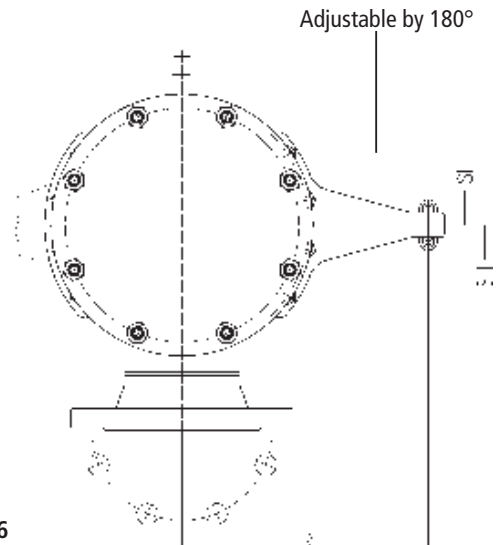
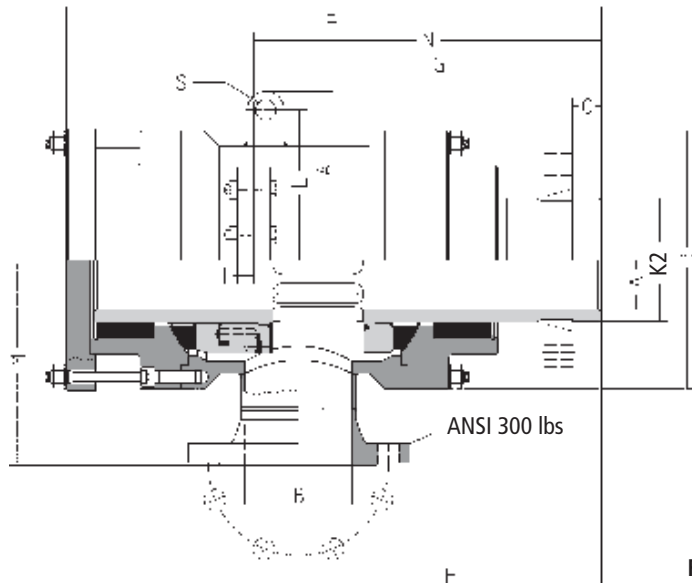

Flanges see page 16

DN	5	6	8	12
Type	HW 1125 K-700	HW 1150 K-700	HW 1200 K-700	HW 1300 K-700
Order-No.	1104001-700	1104101-700	1104201-700	110440-700
Ø A	4.724	5.709	7.677	11.732
B	5	6	8	12
E	25.709	27.795	34.685	51.732
F	14.567	15.472	19.606	27.559
G	16.142	17.323	22.047	33.071
H	0.787	0.984	0.984	1.378
Ø J	12.559	13.622	16.535	23.425
Ø K 2	5.903/5.905	7.084/7.086	9.052/9.055	13.776/13.779
L	7.205	8.268	10.433	15.157
M	9.843	10.157	12.598	19.134
N	16.142	16.260	23.346	33.583
O	1.378	1.575	1.772	2.362
R	11.811	13.780	15.748	27.559
Ø S	0.984	1.575	1.575	1.969
T	0.787	0.984	0.984	1.575
SH	1.220	1.811	1.811	2.283
TA	8.110	9.646	12.008	17.126

HWA2 DN 4 - 12

for two way flow of a medium designed for rotating inner pipe

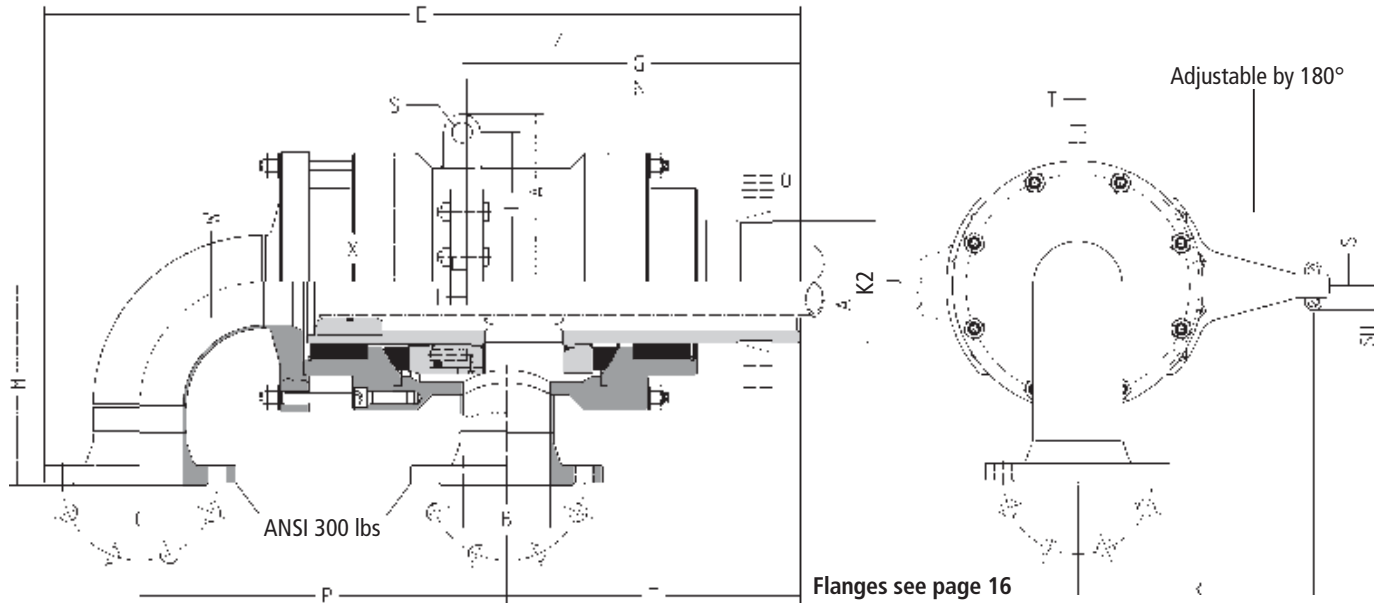

DN	4	5	6	8	12
Type	HWA2100 K-700	HWA2125 K-700	HWA2150 K-700	HWA2200 K-700	HWA2300 K-700
Order-No.	1108890-700	1104002-700	1104102-700	1104202-700	1104402-700
Ø A	3.858	4.724	5.709	7.677	11.732
B	3	4	5	6	10
C	3	4	5	6	10
E	32.087	36.535	40.551	50.630	75.197
F	12.913	14.173	15.512	19.606	27.874
G	14.370	16.339	17.520	22.441	33.071
H	0.787	0.787	0.984	0.984	1.378
Ø J	10.551	12.559	13.622	16.535	23.425
Ø K 2	4.486 / 4.488	5.903/5.905	7.084/7.086	9.052/9.055	13.776/13.779
L	5.984	7.205	8.268	10.433	15.157
M	8.268	9.843	10.157	11.969	19.134
N	14.173	16.142	16.260	23.346	33.583
O	1.181	1.378	1.575	1.772	2.362
P	15.276	17.717	19.764	25.118	38.465
R	9.843	11.811	13.780	15.748	27.559
Ø S	0.984	0.984	1.575	1.575	1.969
T	0.787	0.787	0.984	0.984	1.575
Ø W	2.954 / 2.953	3.466 / 3.465	4.333 / 4.331	5.317 / 5.316	8.467 / 8.465
X	3.150	3.150	3.150	3.937	5.906
Z	20.787	23.307	25.000	31.811	46.024
SH	1.220	1.220	1.811	1.811	2.283
TA	4.606	8.110	9.646	12.008	17.126

Journal Flanges for K Rotor Connection

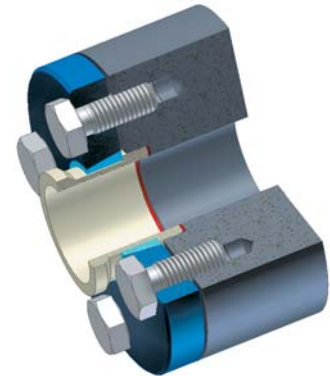
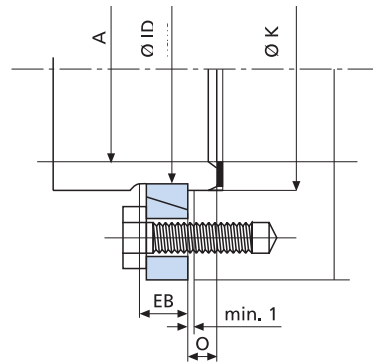
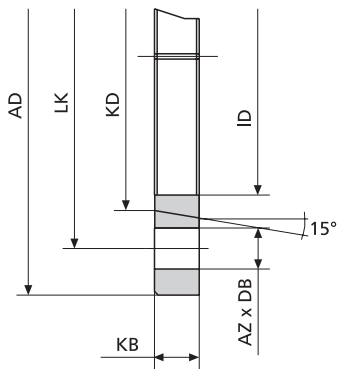

DN	K-flange	Order-No.	Inner ring	Order-No.	Order-No. Gasket	Ø A	Ø AD	Ø LK	AZ x Ø DB	Ø KD	Ø ID	KB	Ø K	O	EB
1/2	KF 15-700	1190431-700	IR 15-700	1190401-700	3512231-700	0.512	3.346	2.638	4x0.374	1.024	0.750/0.752	0.500	0.811/0.813	0.374	0.591
3/4	KF 20-700	1190432-700	IR 20-700	1190402-700	3512232-700	0.728	4.134	2.992	4x0.433	1.260	0.961/0.963	0.591	1.022/1.024	0.437	0.630
1	KF 25-700	1190433-700	IR 25-700	1190403-700	3512233-700	0.945	4.528	3.504	4x0.571	1.457	1.215/1.217	0.591	1.274/1.276	0.437	0.630
1 1/4	KF 32-700	1190434-700	IR 32-700	1190404-700	3512234-700	1.260	4.528	3.504	4x0.571	1.890	1.561/1.563	0.630	1.618/1.620	0.500	0.709
1 1/2	KF 40-700	1190435-700	IR 40-700	1190405-700	3512235-700	1.457	5.039	3.937	4x0.571	2.087	1.770/1.772	0.787	1.872/1.874	0.500	0.866
2	KF 50-700	1190436-700	IR 50-700	1190406-700	3512236-700	1.890	5.827	4.764	4x0.571	2.717	2.226/2.228	0.787	2.325/2.327	0.626	0.866
2 1/2	KF 65-700	1190437-700	IR 65-700	1190407-700	3512237-700	2.362	5.827	4.764	4x0.571	3.504	2.742/2.744	1.024	2.841/2.843	0.748	1.102
3	KF 75-700	1190440-700	IR 75-700	1190420-700	1190191-058	2.835	7.992	6.752	5x0.689	3.504	3.315/3.317	1.220	3.437/3.439	0.874	1.339
3 1/2	KF 80-700	1190438-700	IR 80-700	1190408-700	3512238-700	3.189	8.504	7.008	6x0.689	4.291	3.799/3.803	1.260	3.937/3.939	1.000	1.378
4	KF 100-700	1190409-700	IR 100-700	1190439-700	3512239-700	3.858	8.976	7.520	6x0.689	4.724	4.295/4.299	1.378	4.433/4.435	1.000	1.496
5	KF125-0	1190450	IR125-0	1190410	1190025	4.724	8.858	7.480	6x0.709	5.787	5.394/5.396	0.866	5.588/5.591	0.787	0.984
5	KF125-500	1190450-500	IR125-500	1190410-500	1190035	4.724	10.236	8.858	8x0.709	6.102	5.709/5.71	1.378	5.903/5.906	1.378	1.535
6	KF150-0	1190451	IR150-0	1190411	1190026	5.709	10.039	8.661	8x0.709	7.008	6.496/6.498	0.984	6.690/6.693	0.984	1.102
6	KF150-500	1190451-500	IR150-500	1190411-500	1190036	5.709	11.811	10.236	8x0.709	7.283	6.890/6.892	1.575	7.084/7.087	1.575	1.732
8	KF200-0	1190452	IR200-0	1190412	1190027	7.677	12.205	10.827	8x0.709	9.134	8.661/8.664	1.102	8.855/8.858	1.181	1.260
8	KF200-500	1190452-500	IR200-500	1190412-500	1190037	7.677	14.173	12.598	8x0.709	9.252	8.819/8.821	1.772	9.052/9.055	1.772	1.929
10	KF250-0	1190453	IR250-0	1190413	1190028	9.449	15.354	13.780	8x0.905	11.417	10.748/10.750	1.457	11.020/11.024	1.378	1.575
10	KF250-500	1190453-500	IR250-500	1190413-500	1190038	9.449	17.126	15.354	8x0.905	11.614	10.945/10.947	1.969	11.217/11.220	1.969	2.126
12	KF300-0	1190454	IR300-0	1190414	1190029	11.614	18.504	16.142	16x0.905	13.780	13.071/13.073	1.654	11.382/11.386	1.575	1.772

Loose Flanges for Housing Connection

Sealing with gaskets

The flanges consist of a threaded piece with male thread ISO 228, combined with a slip flange ANSI 300 lbs.

Sealing between flange and rotary joint housing by means of a gasket.

Suitable for HWA, HWB and HWX.

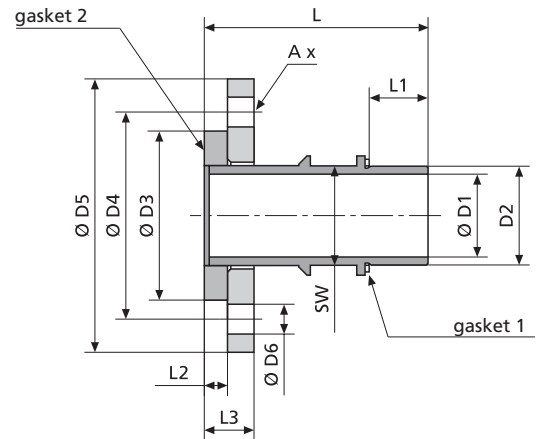
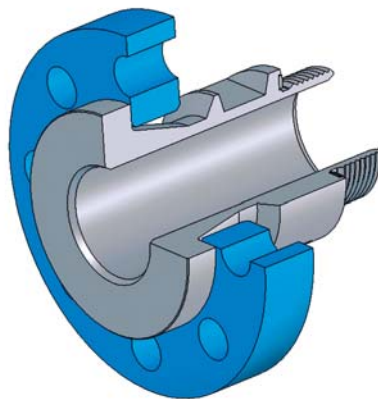

Dimensional table for screw flanges, rated pressure 300 lbs

DN	L	L1	L2	L3	D1	D2	D3	D4	D5	A	D6	SW	Order No. Screw-in flange	Order No. gasket 1	Order No. gasket 2
1	4.409	0.807	0.551	1.260	0.917	G 1 A	2.0	3.500	4.874	4	0.748	1.417	1190203-701	3502111-001	3512622
1 1/4	4.567	0.886	0.551	1.260	1.260	G 1 1/4 A	2.5	3.874	5.248	4	0.748	1.811	1190204-701	3502117-001	3512623
1 1/2	4.724	0.965	0.551	1.260	1.508	G 1 1/2 A	2.9	4.500	6.125	4	0.874	1.969	1190205-701	3502118-001	3512624
2	5.039	1.142	0.630	1.417	1.969	G 2 A	3.6	5.000	6.500	4	0.748	2.362	1190206-701	3502121-010	3512625
2 1/2	5.315	1.260	0.630	1.417	2.520	G 2 1/2 A	4.1	5.874	7.500	8	0.874	2.953	1190207-701	3502124-010	3512626
3	6.220	1.319	0.709	1.575	3.031	G 3 A	5.0	6.625	8.248	8	0.874	3.543	1190208-701	3502125-010	3512627
4	7.087	1.496	0.787	1.654	3.858	G 4 A	6.2	7.874	10.000	8	0.874	4.331	1190209-701	3502108-010	3512628

Maximum application data (pressure reduction factor at higher operating temperatures considered):

- water 406 psi and 446°F
- thermal oil 145 psi bar and 572°F

Please order a gasket 2 for the connection flange, if required.

Material: steel, painted.
Special stainless steel version available upon request.

Spare parts for types H / HW – DN 1/2 - 4

Spare parts H2 + HW2, HR2 + HWR2, H3

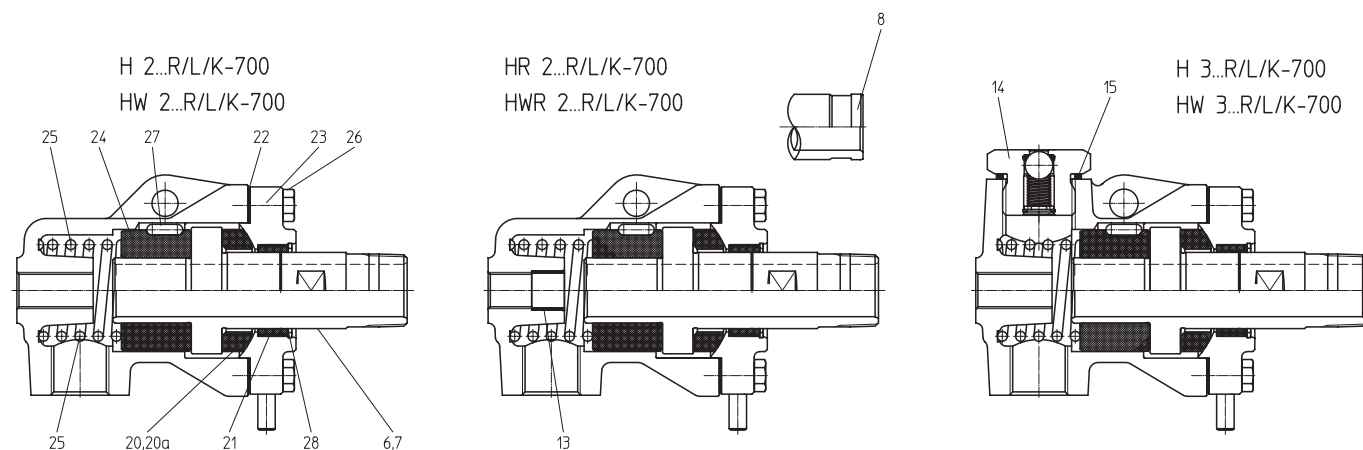

DN	1/2	3/4	1	1 1/4	1 1/2	2	2 1/4	2 1/2	4
6 Rotor R	1103063-602	1103143-602	1103227-602	1103367-602	1103467-602	1103563-602	1103643-602	1103767-602	1103867-602
7 Rotor L	1103064-602	1103144-602	1103228-602	1103368-602	1103468-602	1103564-602	1103644-602	1103768-602	1103868-602
8 Rotor K	1103065-603	1103145-603	1103229-603	1103369-603	1103469-603	1103565-603	1103637-603	1103769-603	1103869-603
13 Slide bearing x	3510502	3510504	3510506	3510501	3510509	3510512	3510514	3510514	3510523
14 Vacuum valve	-	-	1190020	1190020	-	-	-	-	-
15 CU seal	-	-	3511962	3511962	-	-	-	-	-
20 Sealing ring	3511301	3511302	3511303	3511304	3511305	3511306	3511307	3511308	3511309
20a Sealing ring W	3510641	3510642	3510643	3510644	3510645	3510646	3510647	3510648	3510649
21 Cover bearing	3510601	3510602	3510603	3510604	3510605	3510606	3510607	3510608	3510609
22 Flat packing	3512001	3512002	3512003	3512004	3512005	3512006	3512007	3512016	3512017
23 Cover complete	1108059	1108139	1108221	1108361	1108461	1108559	1108653	1108759	1108858
24 Carbon bearing	3511341	3511342	3511343	3511344	3511345	3511346	3511347	3511348	3511349
25 Compression spring	3511616	3511617	3511618	3511619	3511620	3511621	3511622	3511626	3511627
26 Hexagon screw	3500087	3500087	3500087	3500125	3500125	3500165	3500163	3500163	3500197
27 Locking pin	3500932	3500932	3500932	3500933	3500933	3500934	3500934	3500934	3500934
28 Circlip	3500701	3500697	3500702	3500703	3500704	3500705	3500706	3500707	3500708

Please specify exact type designation when inquiring or ordering!

Spare parts for types HWX2 / HWB2 / HWA2 – DN 1 1/4 - 4

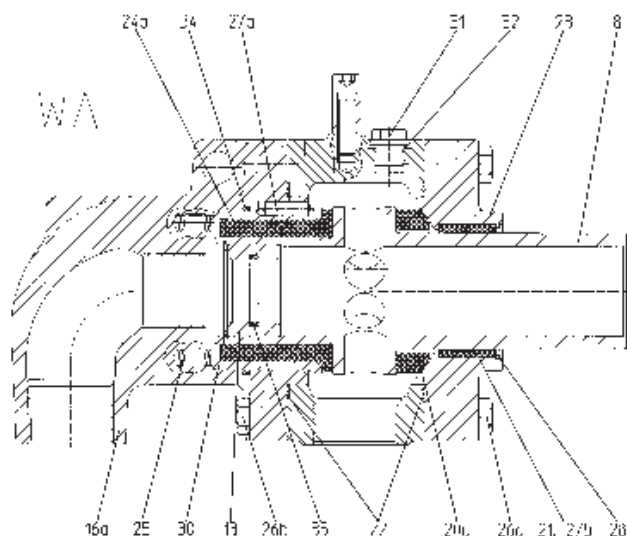
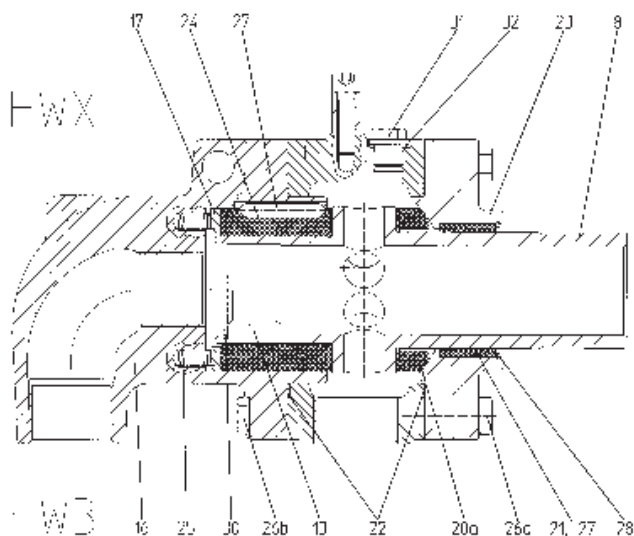

DN	1 1/4	1 1/2	2	2 1/2	3	3 1/2	4
8 Rotor	1103404-703	1103504-703	1103587-703	1103704-703	1103752-703	1103814-703	1103934-703
13 Bushing	1103387-707	1103481-707	1103581-707	1103651-707	1103755-707	1103787-707	1103888-707
16 Elbow B2, X2	1103409-704	1103509-704	1103594-704	1103709-704	1103757-704	1103819-704	1103939-704
16a Elbow A2	1103410-705	1103510-705	1103595-705	1103710-705	1103758-705	1103820-705	1103940-705
17 Thrust washer	1103392-432	1103492-377	1103613-441	1103746-419	1103792-463	1103792-463	1103921-570
20a Sealing ring W	3510644	3510645	3510646	3510647	3510648	3510648	3510649
21 Cover bushing	3510604	3510605	3510606	3510607	3511348	3511348	3511349
22 Gasket	1114193-059	1103799-419	3512013	3512018	1110669-063	1110669-063	3512355-071
23 Cover complete	1103407	1103507	1103592	1103707	1103817	1103817	1103937
24 Carbon bushing B2, X2	3511344	3511345	3511346	3511347	3511348	3511348	3511349
24a Carbon bushing A2	3511344-421	3511345-362	3511346-426	3511347-398	3511348-449	3511348-449	3511349-549
25 Compression spring	5x3511668-001	6x3511668-001	8x3511668-001	4x3511564	8x3511564	8x3511564	12x3511564
26a Hexagon screw 1	8x3500123-008	8x3500124-008	8x3500166-008	8x3500163	8x3500197	8x3500197	8x3500197
26b Hexagon screw 2	8x3500125	8x3500123-008	8x3500165	8x3500163	8x3500197	8x3500197	8x3500197
27 Locking pin B2,X2	1x3500933	1x3500933	1x3500934	1x3500934	2x3500934	2x3500934	2x3500934
27a Locking pin 1 A2	3500951-001	3500933	3500889-001	3500961-001	3500961-001	3500961-001	3500934
27b Locking pin 2 A2	-	-	-	-	3500934	3500934	3500934
28 Circlip	3500703	3500704	3500705	3500706	3501237-001	3501237-001	3501043
30 Circlip	3501234	3501225	3501232	3501236	3501205	3501205	3501251
31 Screw plug	3x3500657	3x3500658-007	3x3500658-007	3x3500655-007	3x3500655-007	3x3500655-007	3x3500655-007
32 Sealing ring	3x3502114-001	3x3502116-001	3x3502116-001	3x3502115-001	3x3502115-001	3x3502115-001	3x3502115-001
34 O-ring	3511701	3511708	3511694	3511692	3511702	3511702	3512515
35 O-ring	3511823	3511732	3511814	3512630	3512630	3511816	3511778

Please specify exact type designation when inquiring or ordering!

Spare parts for type HW1 – DN 5 - 12

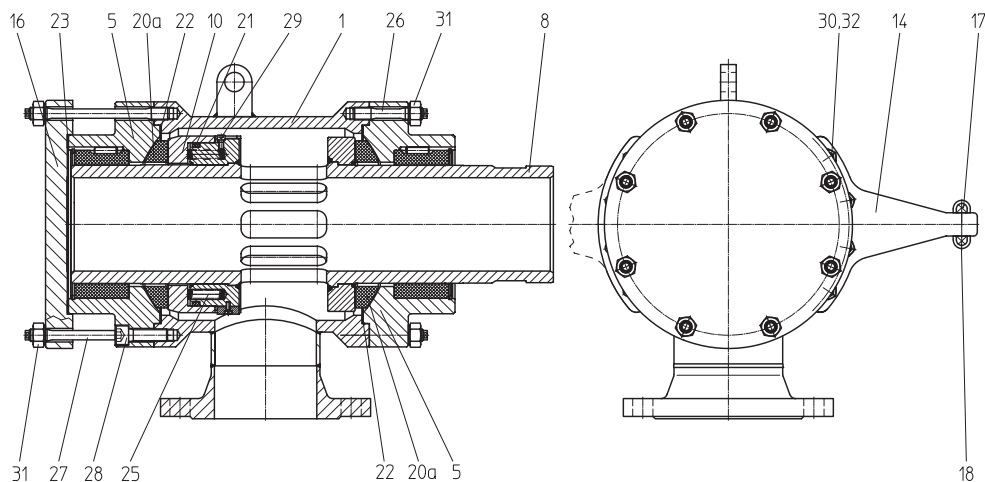

DN	5	6	8	12
5	1104030-200	1104130-184	1104230-129	1104430-040
8	1104054-242	1104154-212	1104254-166	1104454-134
10	1104061-221	1104161-199	1104261-156	1104461-116
14	1104074-231	1104174-209	1104274-163	1104447-137
16	1104045-244	1104145-214	1104245-168	1104445-136
17	1103899-578	1104124-205	1104124-205	1104424-104
18	1103899-579	1104124-206	1104124-206	1104424-106
20a	3511353	3511354	3511355	3511357
21	3512512-015	3512517-015	3511751-015	3512518-015
22	1104075-185	1104175-178	1104275-105	3512022
23	1190037	1104075-185	1105695-050	3512023-063
25	16x3511564	18x3511564	26x3511532	28x3511457
26	8x3500236	8x3500236	16x3500200-008	16x3500248-002
27	8x3500244-007	8x3500432-007	16x3500435-007	16x3500436-007
28	2x3500410	2x3500195	2x3500410	2x3500444
29	2x3500329-003	2x3500433-003	2x3500376-003	2x3500376-003
30	4x3500162-008	4x3500434-008	4x3500434-008	4x3500248-002
31	16x3500300	16x3500300	16x3500300	16x3500304
32	4x3500285-008	4x3500287-008	4x3500287-008	4x3500304
34	2x3500723	2x3500717	2x3500718	2x3500718

Please specify exact type designation when inquiring or ordering!

Spare parts for type HWA2 – DN 4 - 12

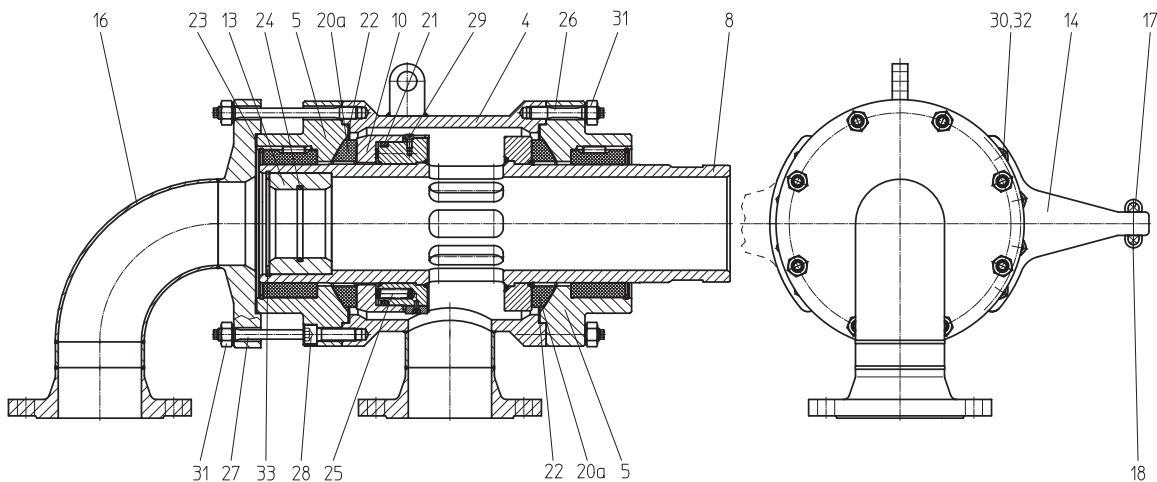

DN	4	5	6	8	12
5 Cover complete (2x)	1103879-541	1104030-200	1104130-184	1104230-129	1104430-040
8 Rotor K complete	1103884-534	1104055-217	1104155-175	1104255-155	1104455-112
10 Butting ring	1103896-539	1104061-221	1104161-199	1104261-156	1104461-116
13 Rotor bushing	1103888-540	1104059-214	1104129-208	1104248-157	1104446-117
14 Anti-rotation device	1103924-542	1104074-231	1104174-209	1104274-163	1104447-137
16 Elbow A2	1103906-536	1104051-224	1104151-197	1104251-160	1104451-108
17 Contact bolt 1	1103899-578	1103899-578	1104124-205	1104124-205	1104424-104
18 Contact bolt 2	1103899-579	1103899-579	1104124-206	1104124-206	1104424-106
20a Sealing ring W	3510649	3511353	3511354	3511355	3511357
21 O-ring	3511703-015	3512512-015	3512517-015	3511751-015	3512518-015
22 Gasket	1103909-335	1104075-185	1104175-178	1104275-105	3512022
23 Gasket	1110518-113	1190037	1104075-185	1105695-050	3512023-063
24 O-ring	3511855	3511826	3511692	3511873	3512519
25 Compression spring	12x3511564	16x3511564	18x3511564	26x3511532	28x3511457
26 Screw 1	16x3500196-007	8x3500236	8x3500236	16x3500200-008	16x3500248-002
27 Screw 2	16x3500209-007	8x3500244-007	8x3500432-007	16x3500435-007	16x3500436-007
28 Cyl. head screw	2x3500428	2x3500410	2x3500195	2x3500410	2x3500444
29 Cyl. head screw	2x3500329-003	2x3500329-003	2x3500433-003	2x3500376-003	2x3500376-003
30 Hexagon screw	4x3500162-008	4x3500162-008	4x3500434-008	4x3500434-008	4x3500248-002
31 Hexagon nut	-	16x3500300	16x3500300	16x3500300	16x3500304
32 Hexagon nut	4x3500285-008	4x3500285-008	4x3500287-008	4x3500287-008	4x3500304
33 Circlip	3501251	3501252-001	3501237-001	3501231	3501264
34 Spring washer	2x3500723	2x3500723	2x3500717	2x3500718	2x3500718

Please specify exact type designation when inquiring or ordering!

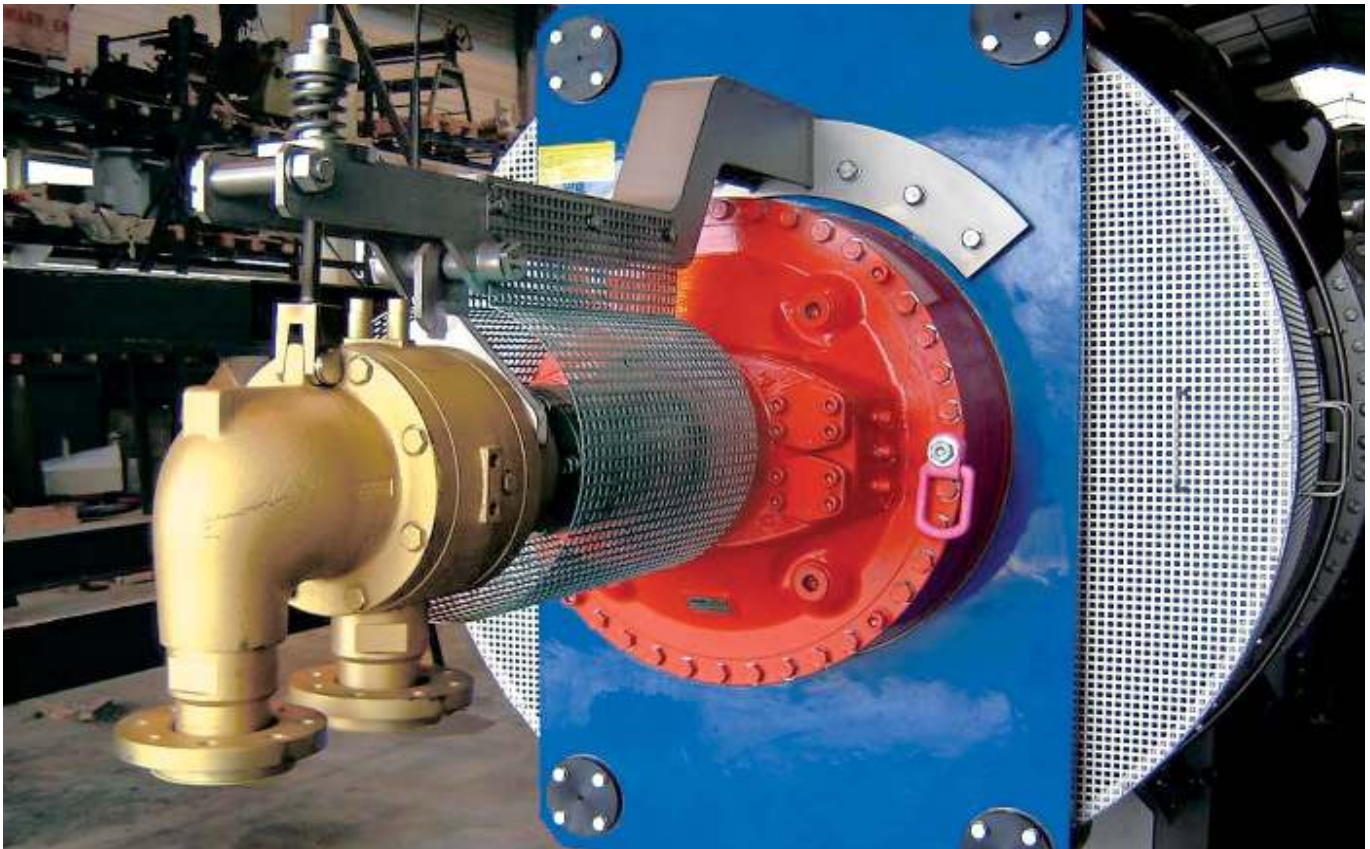
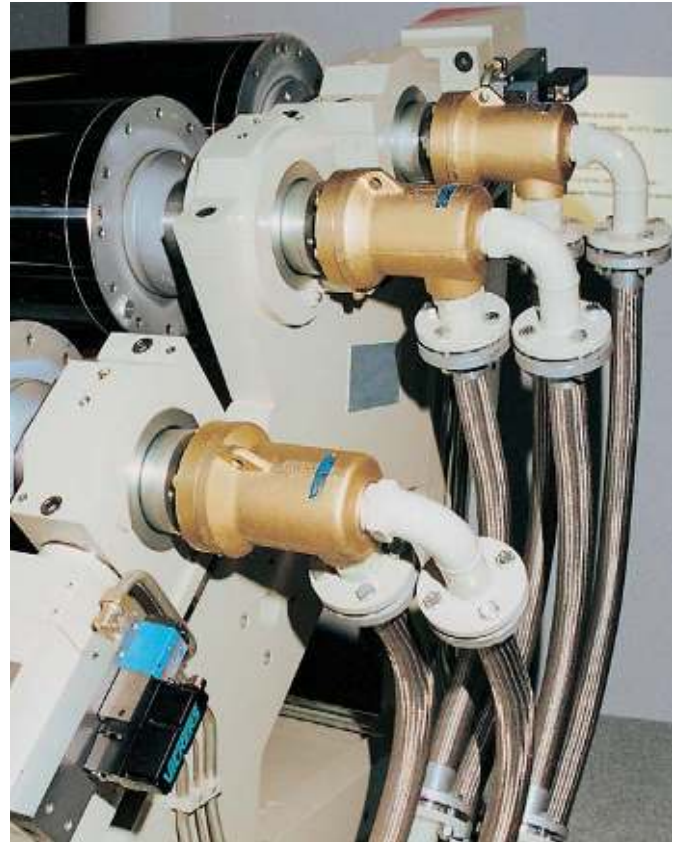

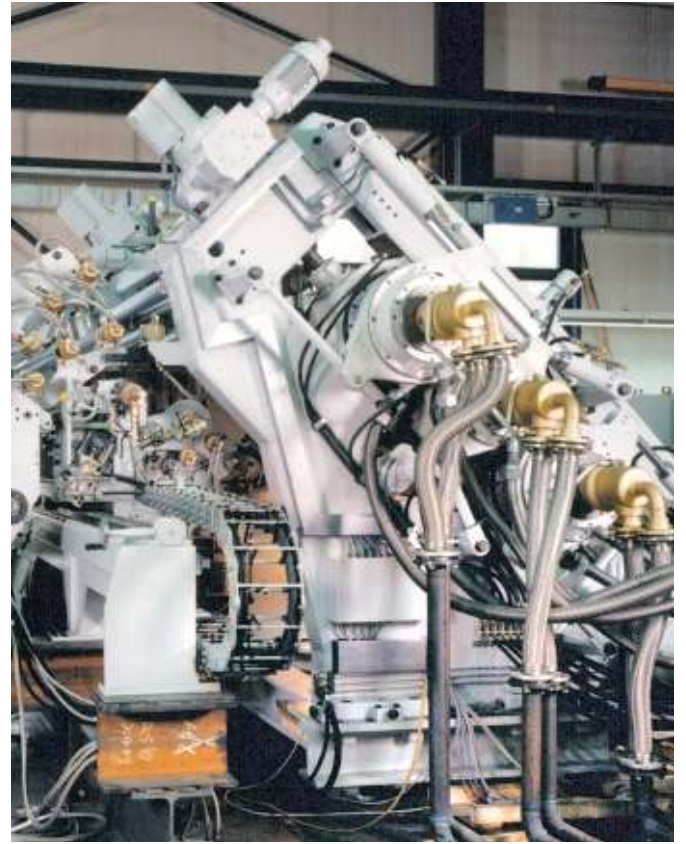

**Headquarter****Christian Maier GmbH & Co. KG
Maschinenfabrik**

Wuerzburger Straße 67-69
D-89520 Heidenheim – Germany

P.O.Box 1609
D-89506 Heidenheim – Germany

☎ + 49 (0) 73 21 / 317-0

☎ + 49 (0) 73 21 / 317-139 (Export)

☎ 0 800 / 7 51 82 50

☎ + 49 (0) 73 21 / 317-239

vkd@maier-heidenheim.de
www.maier-heidenheim.de

Branch Offices & Service Stations:**Maier America LLC**

6669 Peachtree Industrial Blvd., Suite L/M
Norcross, GA 30092 - USA

☎ + 1-770-409 0022

☎ + 1-770-409 0069

info@maieramerica.com

www.maieramerica.com

Maier Italia Srl

Via Enrico Toti 3
I-21040 Gerenzano (VA)

☎ + 39-02-96 24 82 88

☎ + 39-02-96 36 96 95

info@maier-italia.com

www.maier-italia.com