



Testing technology
The right thing for testing



The testing sector is versatile and demanding.

The selection of the right components for hydraulic test stand are decisive for the optimal operation for a testing machine.

Hänchen has one of the largest test actuator ranges on the market and also manufactures other components for test stand construction in a wide variety of industries. We also offer you the implementation of complete, individual test machines.

- Automotive
- Aerospace
- Railway engineering
- Medical technology
- Testing technology
- Wind power



Hänchen. Hydraulics are in our genes.

Hydraulic cylinders	4
Clamping unit Ratio-Clamp®	18
Technical data	20

Exactly right.
Perfect.



- 1 Hexapod: simulation of a driving route
- 2 Seal and rod test stand: determination of friction and leakage
- 3 Airplane wing test stand: simulation of environmental conditions acting on landing flaps

Which cylinder design is the right one for your requirements? The performance map serves for orientation purposes and describes the dynamic movement of a hydraulic drive during a sinusoidal oscillation. The performance classes of the different cylinder designs define the possible applications.

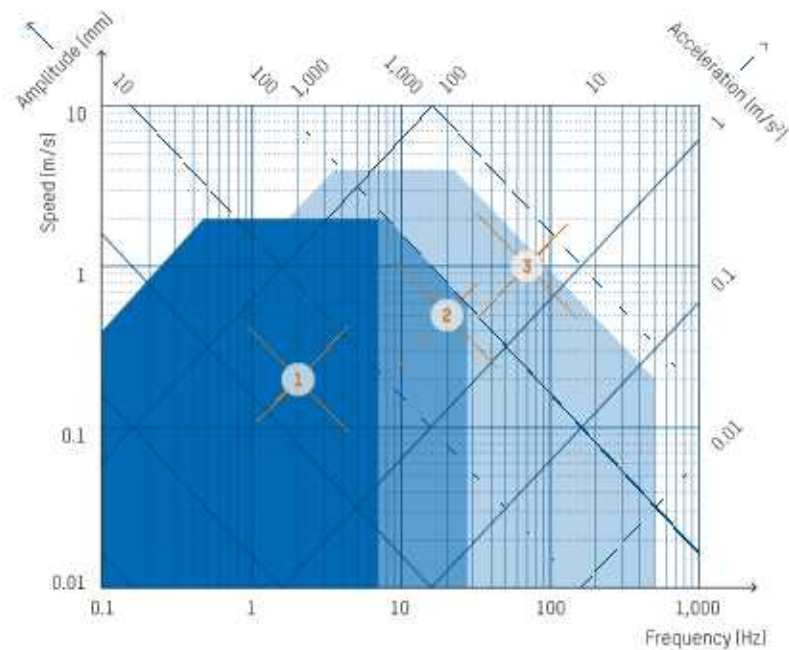

Examples for performance map



	Series 120, 300 1 Single-rod	Series 120, 300 2 Double-rod	Series 320 3 Double-rod
Frequency [Hz]	2	20	70
Amplitude [mm]	16	4	2.3
Speed [m/s]	0.2	0.5	1
Acceleration [m/s ²]	3	63	440

Limit values in the performance map without accounting for construction restrictions such as part size, sealing system, guiding system or control valve.



+ Servo cylinders of the series 120 and 300: slight test actuators for simple testing tasks

In typical Hänchen quality – high quality honed surfaces, components with geometrical accuracy, and coordinated sealing elements – these servo cylinders fulfil highest technical requirements for safe and reliably controlled drives.

+ Advantages

- Optimal price-performance ratio
- Especially suited for test tasks with long strokes
- As single-rod or double-rod cylinder
- With integrated position transducer
- Low dead weight
- Optionally with mounting plate for control valve

Technical data servo cylinders

Series with PT	Max. pressure [bar]	Bore [mm]	Force [kN]	Stroke [mm]
120	150*	40–100	19–382	1–1,500
300	300	50–140	59–462	1–1,500

Type of effect: single-rod, double-rod
Sealing systems: basic design, Servocop®, Servoseal®, Servofloat®

* When mounting with pivot mounting, the pressure is limited to 120 bar.
PT = position transducer
You can find detailed specifications on page 22.



You can find the exact dimensions and the data sheets in our product configurator at www.haenchen-hydraulic.com.

Dynamics for test winners.



Efficient and cost-effective with varying test setups, compact, versatile, quick, sensitive and robust – test actuators of series 320 are the best choice for challenging tasks.

For example, they can be used for checking the functional safety of systems, component parts or products, for structural testing of airplanes, refrigeration compressors, automobile exhaust systems, or for simulating loads and movement, such as operational profiles and flight profiles.

+ For every frequency range and for high lateral forces

The test actuators convince with their stability and high inherent stiffness. They are suitable for high speeds and can reliably bear high lateral forces.



+ Modular system for efficient change of applications

Mounting parts and accessories such as spherical rod eyes, integrated position transducers, force transducers, mounting plates, accumulators or control valves fit cylinders with different forces and do not have to be purchased several times for one test field.

+ Operation without leak oil pump

Thanks to the elaborate sealing and guiding system, Hänchen cylinders don't need leak oil pumps.

+ Protection against unforeseen movement

The emergency cushion serves for self-protection of the cylinder and test specimen, and is included in the stroke as standard. The effective stroke is between the two emergency cushioning.

+ Bores adjustable to the millimetre

The working areas can be designed individually for the respective requirements. This saves acquisition and operating costs for the required periphery and increases the energy efficiency, e.g. with regard to the system's energy input and cooling power.

- 1 Test stand for seats: service strength test for vehicle seats
- 2 Large bearing test stand: simulation of forces and moments acting on roller bearings of wind turbines
- 3 Testing facility: testing of car bodies and vehicle structures

Technical data test actuators

Series	Max. pressure (bar)	Rod Ø (mm)	Force (kN)	Stroke (mm)
320	320	25-200	up to 1,568	50-450

Type of effect: double-rod

Sealing systems: Servoseal®, Servofloat®, Servobear® functional oil seal

Further detailed information as well as a list sorted according to force extending with details of lateral forces can be found on page 20|21.



HAKO

You can find design and calculation assistants in our product configurator at www.haenchen-hydraulic.com.

Unlimited possibilities.
Accurate fitting combinations.



For further details on this and other equipment features, please refer to our book "Hydraulic Systems".

Tests in salt spray fog, in climatic chambers or in a lab: we fit your cylinder up for anything. Tell us what you need – only those who set conditions get the perfect cylinder.

Equipment in the cover

For the perfect combination, the cover type with the best sealing and guiding system* with matching quality of piston rod and the right sealing material is selected based on your application.

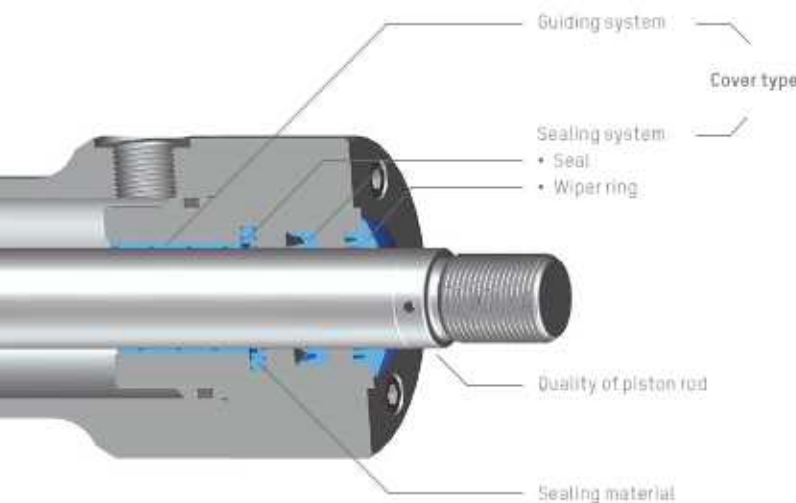

SEALING SYSTEM

Basic design

Lip seal, wiper ring

Servocop®

Compact seal, lip seal, wiper ring

Servoseal®

Servoseal®, lip seal, wiper ring

Servofloat®

Floating gap seal, functional oil seal, wiper ring

Functional oil seal

Functional oil seal, wiper ring

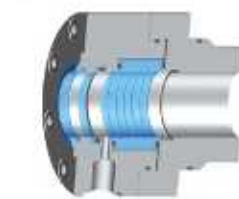

GUIDING SYSTEM



**Servoslidex®
Synthetic guide**

- Simple movements
- Long-stroke oscillations
- Side loads due to lateral movement
- Low stick-slip
- $v \leq 0.5 \text{ m/s}$

- Controlled movements
- Long-stroke oscillations
- Side loads due to lateral movement
- Mostly stick-slip-free
- $v \leq 2 \text{ m/s}$

- Sensitive movements
- Long- and short-stroke oscillations
- Side loads due to lateral movement
- Low-wear
- $v \leq 2 \text{ m/s}$

- Sensitive movements
- Long- and short-stroke oscillations
- Side loads due to lateral movement
- Low-wear
- $v \leq 2 \text{ m/s}$



Metallic guide

- Simple movements
- High temperatures
- Universal application
- Low stick-slip
- $v \leq 0.5 \text{ m/s}$

- Simple movements
- High temperatures
- Mostly stick-slip-free
- $v \leq 1 \text{ m/s}$

- Simple movements
- Temperatures up to 80 °C
- Low-wear
- $v \leq 1 \text{ m/s}$

- Simple movements
- High temperatures
- Low-wear
- $v \leq 1 \text{ m/s}$



PTFE Wear rings

- Controlled movements
- Long-stroke oscillations
- Side loads due to lateral movement
- Long cylinder stroke
- Mostly stick-slip-free
- $v \leq 3 \text{ m/s}$

- Sensitive movements
- Long- and short-stroke oscillations
- External side loads or due to lateral movement
- Low-wear
- $v \leq 2 \text{ m/s}$

- Sensitive movements
- Long- and short-stroke oscillations
- External side loads or due to lateral movement
- Low-wear
- $v \leq 4 \text{ m/s}$



**Servobear®
Hydrostatic bearing**

- Sensitive movements
- Short-stroke oscillations, highly dynamic
- Highest side loads
- No leak oil pump required
- $v \leq 4 \text{ m/s}$

* The recommended cover type also depends on the series and the piston equipment.

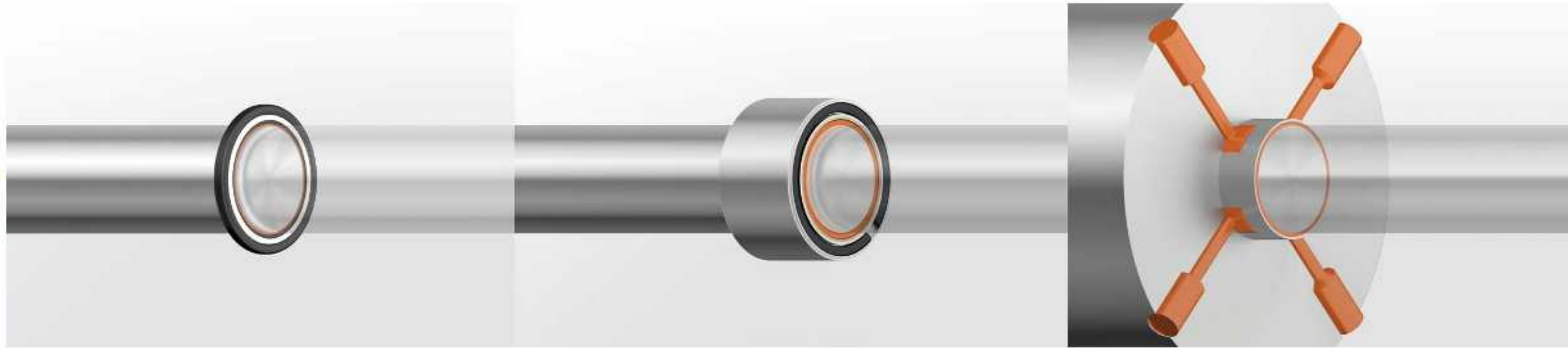

A dynamic test environment requires free-moving, low stick-slip hydraulic cylinders. Hänchen offers three test actuator designs with especially low friction. High production accuracy with very little guide clearance guarantees wear-free use and thus a long service life.

Servoseal® – H-CFRP® retaining ring

- + Servoseal® design with H-CFRP® retaining ring to avoid functional oil

Servoseal® is a dynamically sealing synthetic ring. The integrated retaining ring made of H-CFRP® prevents excessive pressure build-up on the sealing surface due to hydraulic pressure. Even at small amplitudes, no wear and no scoring is produced on the counterfaces due to deficient lubrication.

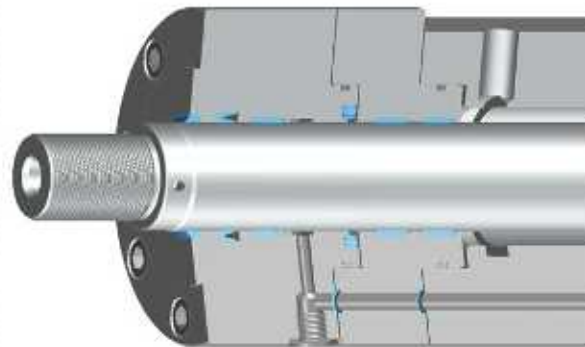

Servofloat® – Floating gap seal

- + Servofloat® design with patented floating gap seal for extremely low friction

In the Servofloat® sealing element, the pressure in the cylinder chamber is discharged to the outside through a narrow no-contact throttle gap. The ring centres itself on the piston rod and seals without contact. This system requires no external pressure supply.

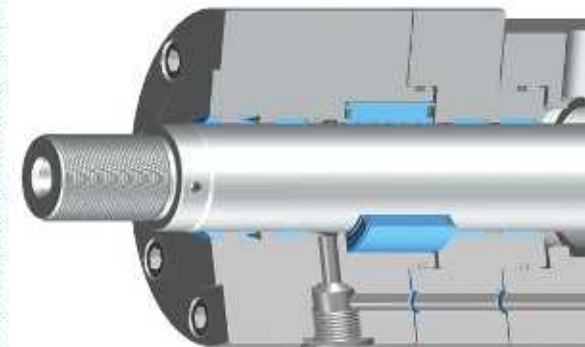

Servobear® – Hydrostat

- + Servobear® design with hydrostatic piston rod guide for highest side loads

Servobear® combines seal and rod guide. The rod is "floating" on an oil film without touching the guide. The pressure is released through this narrow bearing gap. The pressure supply for the hydrostatic bearing is realised internally via the system pressure.

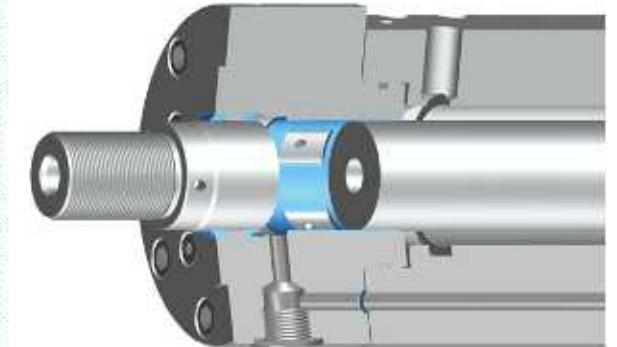

Exclusive for series 320.



You can find videos of these equipment versions on our YouTube channel at www.youtube.com/Haenchen.



Don't hesitate to contact us, we will be pleased to advise you! You can find our contact details on www.haenchen-hydraulic.com

+ The perfect sealing system on the piston

Beside the selected cover type, the right piston design is also crucial for the dynamic movement of the cylinder. We select the right piston for your cover type, exactly meeting your requirements.

+ Functional oil flow from cover and leakage from piston

The Servoseal® sealing system or gap seals are used on the cover or piston for highly friction-sensitive applications with small amplitudes. Servoseal® generates very little leakage, which is hardly measurable during operation. This enables very high hydraulic efficiencies to be achieved.

Gap seals operate with a functional oil flow which is discharged into the tank without pressure via the leak oil port. It must not be sucked off.

Equipment on the piston

SEALING SYSTEM

Rectangular compact seal

Servoseal®

Throttle gap (without seal)



GUIDING SYSTEM

Metallic guide

- | | | |
|--|---|--|
| <ul style="list-style-type: none"> • Simple movements • Long-stroke oscillations with movements longer than the seal width • Piston leakage: none • Pressure-dependent friction • $v \leq 4 \text{ m/s}$ | <ul style="list-style-type: none"> • Sensitive movements • Long- and short-stroke oscillations • Piston leakage: very low • Low friction • $v \leq 4 \text{ m/s}$ | <ul style="list-style-type: none"> • Sensitive movements • Long- and short-stroke oscillations • Piston leakage: high • Very low friction • $v \leq 4 \text{ m/s}$ |
|--|---|--|

Functional oil flow from the cover

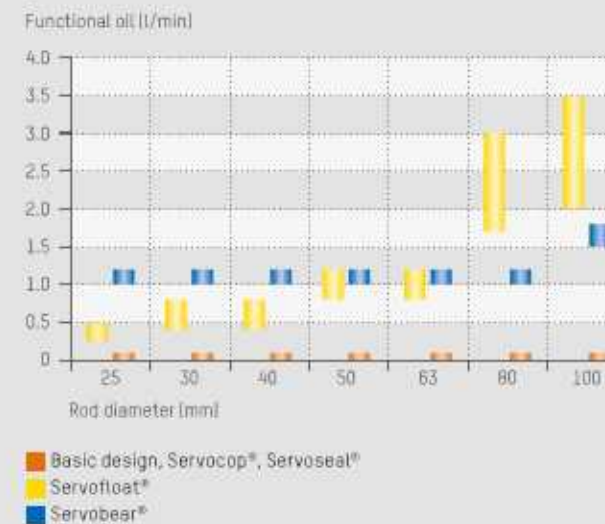

Reference values apply for a cover at 210 bar chamber pressure (working pressure), ISO VG 46 fluid at 55 °C.

Leakage from the piston



Reference values apply to 210 bar differential pressure at the piston, ISO VG 46 fluid at 55 °C.

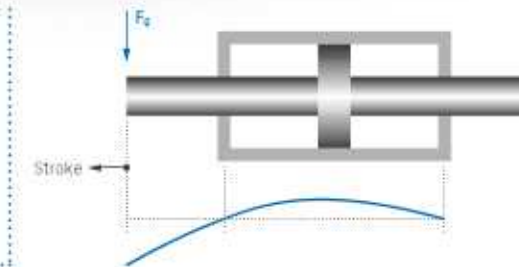

1 Bending line of the piston rod generated by lateral force

+ Low level of friction force

Whether sensitive, free-moving or robust – the strength of Häfenchen cylinders is in their extreme adaptability.

Depending on what you need, we offer you the right cover type with optimal friction force for your static or dynamic application.

+ Design in relation to lateral forces

The amount of permitted lateral forces is mainly determined by the rod diameter, the guiding system and the cylinder stroke. This results in different values per stroke position. The permitted lateral force in the retracted end position is therefore always greater than in the extended position.

For cylinders with longer strokes, the selection of the sealing and guiding systems are of little consequence in regard to resistance to lateral forces.

Friction in dependence on sealing and guiding system in the cover

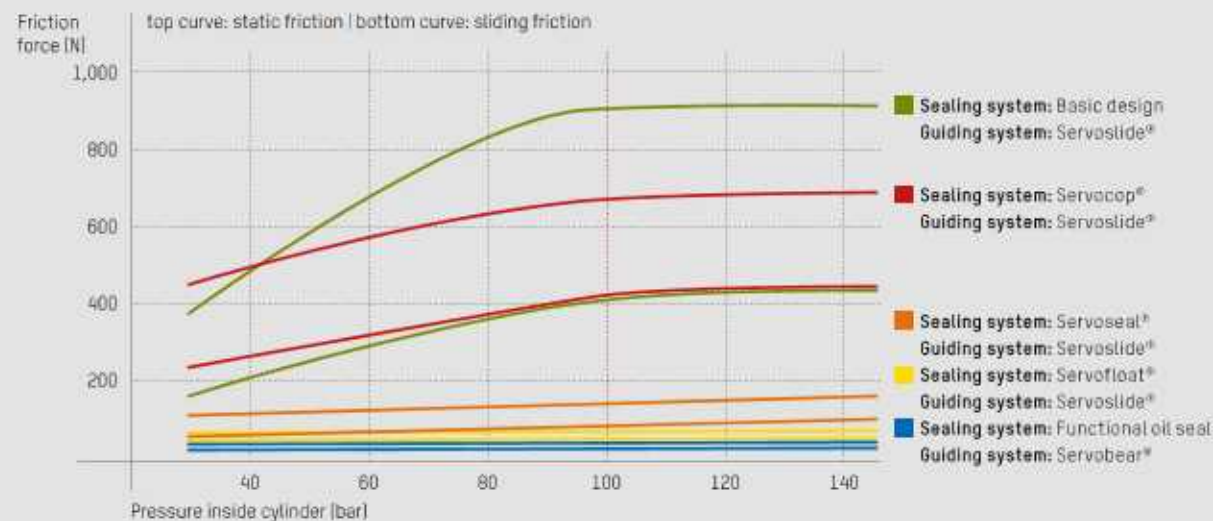

Values measured on the double-rod cylinder (bore 46 mm without seal, rod Ø 40 mm) during sine operation according to VDMA24577 at 50 °C/HLPD46. The level of the friction force curves is lower than usual on the market.

Permitted lateral forces in relation to the stroke length

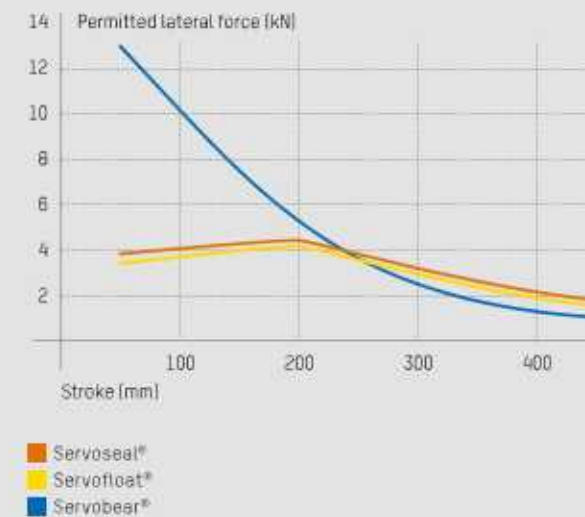

Reference values apply to a rod Ø of 63 mm at the middle stroke position of the series 320.



You can find construction assistants and the exact lateral forces for every dimension of the series 320 in our product configurator at www.haenchen-hydraulic.com.



Special tasks? Individual solutions!



- 1 Hydraulic cylinder with pressure protection tube in a test of the interface between airplane and landing gear
- 2 Material test stand: structure test of airplane wings using synchronous cylinders
- 3 Burst test: pipes are tested using pressure intensifiers

With decades of expertise in developing and manufacturing special solutions, our development team is always there for you. Whenever possible, we use minor modifications of our modular standard elements to adapt them to your requirements as cost-effectively as possible. If necessary, we can even develop entirely new solutions for you.

+ Example 1: hydraulic cylinder with pressure protection tube

For weight compensation or to obtain a resilience effect, sometimes initial loads must be applied to the test objects. This is a job for hydraulic cylinders with a pressurised protection tube. Drive and hydraulic spring are combined in one component.

On the protection tube side, a double-rod cylinder on the piston rod is pressurised with pressure from an accumulator. Thus, the working area A3 acts as a "protection tube spring". With its two chambers A1 and A2, the cylinder works in addition to this continuous hydraulic force.

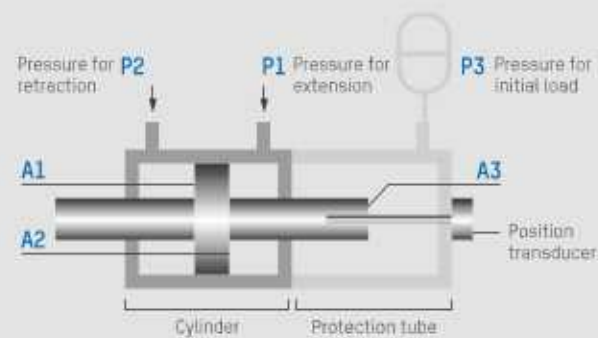

+ Example 2: synchronous cylinder

Hydraulic cylinders with working areas of the same size are convenient for dynamic movement. Synchronous cylinders are the solution for constricted spaces or long-stroke test tasks.

Their length corresponds to that of cylinders with single-sided piston rods. A large rod, in which a smaller rod is moving, transfers the force to the outside. This creates two working areas of the same size, A3 for extension and A2 for retraction.

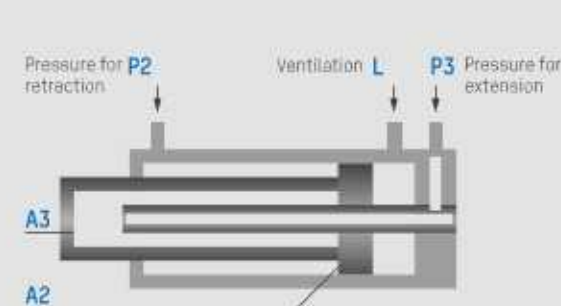

+ Example 3: pressure intensifier

With a hydraulic cylinder (primary cylinder) actuated by a servo-hydraulic drive, any operational profile for the piston rod can be created. This operational profile creates a user-defined pressure pattern in the high-pressure chamber, which can be applied to a test object as test pressure.

Components can, for example, be vibrated with internal pressure – ideal for bursting tests of hollow objects such as hoses, pipes and containers. The test actuator can work with hydraulic oil, while the high-pressure part uses water or other environmentally-friendly fluids.

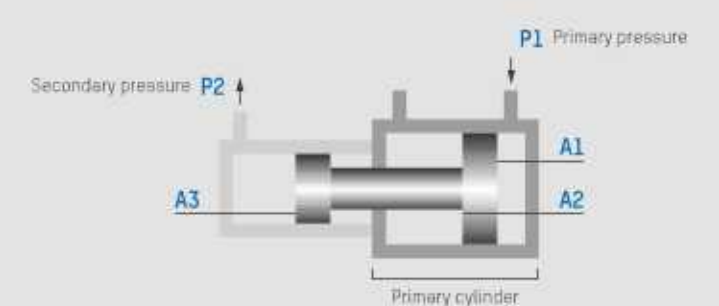



Keeps the position for you!



The patented clamping unit Ratio-Clamp® serves to protect human and machine in case of a power failure or system shutdown. It fixes test specimens and axes during the process or for highly dynamic applications and test processes.

+ Use

- Fixation of all types of round rods in any position
- Out of a standstill
- Clamping force without energy supply for unlimited time
- An additional safety component for gravity loaded axes

+ Safe advantages

- Can be used horizontally and vertically
- Can take tension and pressure in any direction
- Immediate clamping effect without further rod movement
- Wear-free hold without play, even with vibrations of the application
- Energy-efficient thanks to pressureless clamping process

+ Sealing system Servocop®

The basic type of Ratio-Clamp® uses the friction-optimised sealing system Servocop®. Here, the primary seal touches the rod. The maximum speed of the rod is 1 m/s.

+ Sealing system pressure piston seal

For very sensitive applications, we recommend the design with pressure piston seal, where no pressurised seal is touching the rod. Thus, the sliding friction is very low and remains constant regardless of the releasing pressure. The maximum speed of the rod is 2 m/s.



Technical data

Ratio-Clamp*	Rod Ø (mm)	Force (kN)
Standard design	16 - 160	1 - 750
Special solution	up to 300	up to 2,000

Suitable for: all hydraulic cylinders, round rods
 Certification: TÜV, DGUV Test
 Sealing systems: Servocop®, pressure piston seal

Servocop®

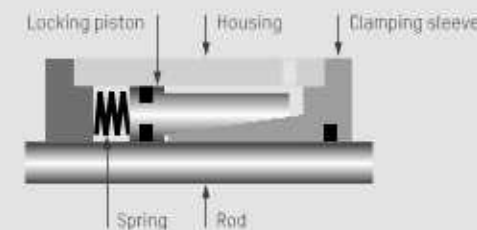

Pressure piston seal

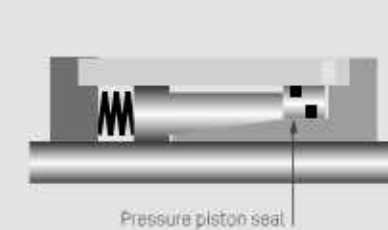

112 Wing test stand: air flow simulation, clamping unit immobilises individual axes during the test process
 3 Tyre test stand: determination of the operation time, clamping unit holds the adjusted angular position of the wheel during the fatigue test



You can find further information on Ratio-Clamp® in our brochure "Clamping unit".



You can find the exact dimensions and the data sheets in our product configurator at www.haenchen-hydraulic.com.

+ According to rod diameter

Rod Ø (mm)	Type	Bore (mm)	Force (kN) 210 bar	Force (kN) 320 bar	Stroke (mm)
25	strong	28- 45	2.6- 23.1	4.0- 35.2	50-170
30	strong	34- 55	4.2- 35.0	6.4- 53.4	50-220
40	strong	45- 70	7.0- 54.4	10.7- 82.9	50-270
50	strong	56- 80	10.5- 64.3	16.0- 98.0	50-450
63	strong	70-110	15.4-134.1	23.4-204.4	50-450

Rod Ø (mm)	Type	Bore (mm)	Force (kN) 210 bar	Force (kN) 320 bar	Stroke (mm)
80	strong slim	90-150 -120	28.0-266 -132	42.7-405 -201	50-450
100	strong slim	110-175 -150	34.6-340 -206	52.8-518 -314	50-450
125	strong slim	140-200 -175	65.6-402 -247	100-613 -377	50-450
160	strong slim	200-260 180-220	238-693 112-376	362-1,056 171-573	50-450
200	strong slim	250-320 240-280	371-1,029 290-633	566-1,568 442-965	50-350 -450

strong: massiv construction (e.g. vertical installation) | slim: light construction (e.g. horizontal installation with spherical rod eyes)

+ According to nominal force

Nominal force	Design	Rod Ø (mm)	Bore (mm)	Force (kN) 210 bar	LATERAL FORCE WHEN EXTENDED (kN) STROKE 100 **			LATERAL FORCE WHEN EXTENDED (kN) STROKE 250 **		
					Servoseal®	Servofloat®	Servobear®	Servoseal®	Servofloat®	Servobear®
4 kN	light rod	25	30	4.5	0.31	0.27	0.51			
	normal rod	30	34	4.2	0.51	0.44	1.0			
6,3 kN	light rod	30	36	6.5	0.51	0.44	1.0			
	normal rod	40	45	7.0	1.6	1.5	2.5	0.57	0.54	0.67
10 kN	light rod	30	39	10.2	0.51	0.44	1.0			
	normal rod*	40	47	10.0	1.6	1.5	2.5	0.57	0.54	0.67
16 kN	light rod	30	44	17.1	0.51	0.44	1.0			
	normal rod*	40	51	16.5	1.6	1.5	2.5	0.57	0.54	0.67
	reinforced rod	50	59	16.2	2.8	2.4	4.6	1.6	1.2	1.2
25 kN	light rod*	40	56	25.3	1.6	1.5	2.5	0.57	0.54	0.67
	normal rod	50	64	26.3	2.8	2.4	4.6	1.6	1.2	1.2
	reinforced rod	63	74	24.9	3.8	3.6	7.8	3.2	2.9	2.3
40 kN	light rod	40	64	41.2	1.6	1.5	2.5	0.57	0.54	0.67
	normal rod*	50	70	39.6	2.8	2.4	4.6	1.6	1.2	1.2
	reinforced rod	63	80	40.1	3.8	3.6	7.8	3.2	2.9	2.3
63 kN	light rod*	50	80	64.3	2.8	2.4	4.6	1.6	1.2	1.2
	normal rod	63	88	62.3	3.8	3.6	7.8	3.2	2.9	2.3
	reinforced rod	80	101	62.7	6.7	6.4	13.3	4.5	5.1	4.4
100 kN	light rod	63	100	99.5	3.8	3.6	7.8	3.2	2.9	2.3
	normal rod*	80	112	101.3	6.7	6.4	13.3	4.5	5.1	4.4
	reinforced rod	100	127	101.1	11.1	10.3	24.9	9.7	8.7	9.7
160 kN	light rod*	80	127	160.5	6.7	6.4	13.3	4.5	5.1	4.4
	normal rod	100	140	158.3	11.0	10.3	24.9	9.7	8.7	9.7
	reinforced rod	125	160	164.5	16.2	15.1	49.5	15.9	14.6	23.9
250 kN	light rod	100	160	257.3	11.0	10.3	24.9	9.7	8.7	9.7
	normal rod*	125	175	247.4	16.2	15.1	49.5	15.9	14.9	23.9
	reinforced rod	160	202	250.8	24.7	22.1	81.6	24.0	22.7	42.2
400 kN	light rod*	125	200	402.0	16.2	15.1	49.5	15.9	14.6	23.9
	normal rod	160	225	412.7	24.7	22.1	81.6	24.0	22.7	42.2
	reinforced rod	200	255	412.7	31.7		99.1	30.6		58.4
630 kN	normal rod*	160	255	650.3	24.7	22.1	81.6	24.0	22.7	42.4
	reinforced rod	200	280	633.3	31.7		99.1	30.6		58.4
1,000 kN	normal rod*	200	320	1,029.2	31.7		99.1	30.6		58.4

The assignment of the piston to the nominal force serves for orientation purposes. For optimised design under consideration of hydraulics, dynamics or weight, please use the calculation in our product configurator H&K at www.haenchen-hydraulic.com.

* Reference to common standard dimensions

** The mechanical guiding systems of Servoseal® and Servofloat® are limited by the permissible surface pressure, but can absorb very high lateral forces and deflections during long strokes. Hydrostatic bearings (Servobear®) are characterised by a very high bearing and lateral load capacity, especially with short strokes.

+ Dimensions with position transducer

Bore (mm)	Rod Ø (mm)	SERIES 120	SERIES 160	SERIES 300
		150 bar* Force F ₁ F ₂ (kN)	ISO 6020-1 160 bar Force F ₁ F ₂ (kN)	300 bar Force F ₁ F ₂ (kN)
40	25	18.8 11.5	-	-
50	25	29.5 22.1	-	-
	28	-	31.4 21.6	-
	30	29.5 18.8	-	58.9 37.7
	40	-	-	58.9 21.2
60	30	42.4 31.8	-	-
	40	42.4 23.6	-	84.8 47.1
	50	-	-	84.8 25.9
63	36	-	49.9 33.6	-
80	40	75.4 56.5	-	-
	45	-	80.4 55.0	-
	50	75.4 45.9	-	150.8 91.9
	60	-	-	150.8 66.0
100	50	117.8 88.4	-	-
	56	-	125.7 86.3	-
	60	117.8 75.4	-	235.6 150.8
	80	-	-	235.6 84.8
125	60	184.1 141.7	-	-
	70	-	196.3 134.8	-
	80	184.1 108.7	-	368.2 217.4
	100	-	-	368.2 132.5
140	80	230.9 155.5	-	-
	100	230.9 113.1	-	461.8 226.2
160	80	301.6 226.2	-	-
	100	301.6 183.8	-	-
180	100	381.7 263.9	-	-
	120	381.7 212.1	-	-

* When pivot mounted, the pressure is limited to 120 bar.

F₁ = Compressive force while the cylinder is extended | F₂ = Compressive force while the cylinder is retracted
With double-rod cylinders, retraction and extension corresponds to the value F₂.



Basis for a successful collaboration.

Do you need support? At Hänchen, we offer you comprehensive all around advice and fast support.

For all questions and problems regarding virtually anything, such as accessories and tools, we are always at your side. Because we want to give you the best drive solution and smooth test scenarios for your individual requirements: by minimising the time required for installation and maintenance, and providing the best functional reliability.

At www.haenchen-hydraulic.com, you will find further information on:

- Technical information
- Applications
- Installation and maintenance



If required, we also supply suitable matching accessories: from mounting plates, valves and accumulators to flanges and force transducers.



Do you need support or further dimensions? Speak to us. We provide you with comprehensive advice and support you during the design phase. You can find our contact details at www.haenchen-hydraulic.com.



You can find design and calculation assistants together with data sheets in our product configurator at www.haenchen-hydraulic.com.

Herbert Hänchen GmbH & Co. KG
Brunnwiesenstr. 3, 73760 Ostfildern
Postfach 4140, 73744 Ostfildern
Germany
Fon +49 711 44139-0
info@haenchen.de
www.haenchen-hydraulic.com



HÄNCHEN®