

**ECKART**<sup>®</sup>  
[HYDRAULIK · PNEUMATIK]

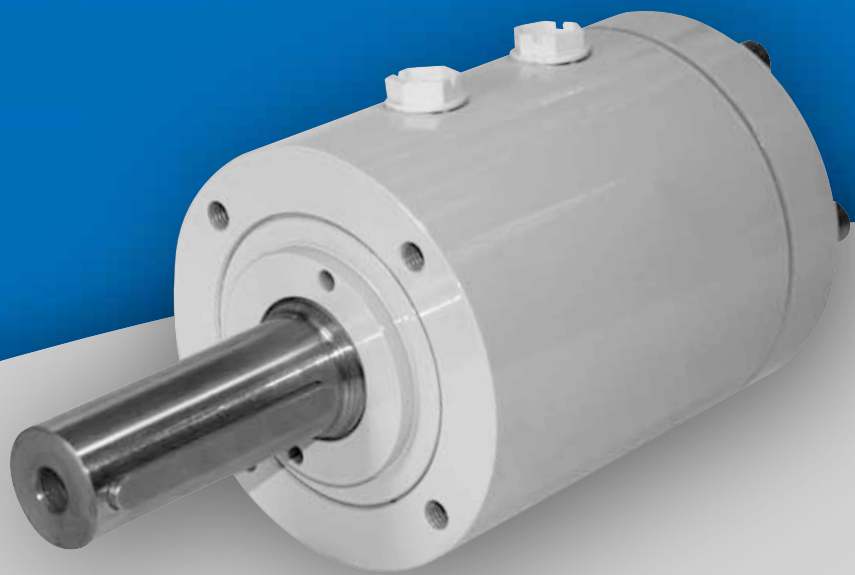

**Rotary actuator E1**  
Hydraulic / 100 bar

[ GATEWAY  
to new technologies. ]

### minimal required space

- we took great care, by the development, to have small dimensions

### low hydraulic axial load on drive shaft

#### through small differential

- less load on the ball bearing, freeing it for more important tasks
- extending the service life of the rotary actuator

### adjustable drive shaft datum

- if you manufacture the hub, it is not necessary to regard the exact position of the keyways.
- the total angle can be re-adjusted at any time

### ball bearing

- in spite of the possibility is the radial- and axial power through the application of ball bearings by low hydraulic pressure warranted

### modern sealing technology

- extended service life of seals
- increased safety, also with regard to the environment
- suitable for most fluids
- all installation places have the smallest possible tolerances, in case of that, do we avoid a gap extrusion of the seals.
- no internal leakages through solid seals enabling the load to be held in any intermediate position

### flexible mounting possibility

- if front-flange- or foot mounting, with or without threads, we can fit the E1 on all kind of practicable technical mounting possibilities

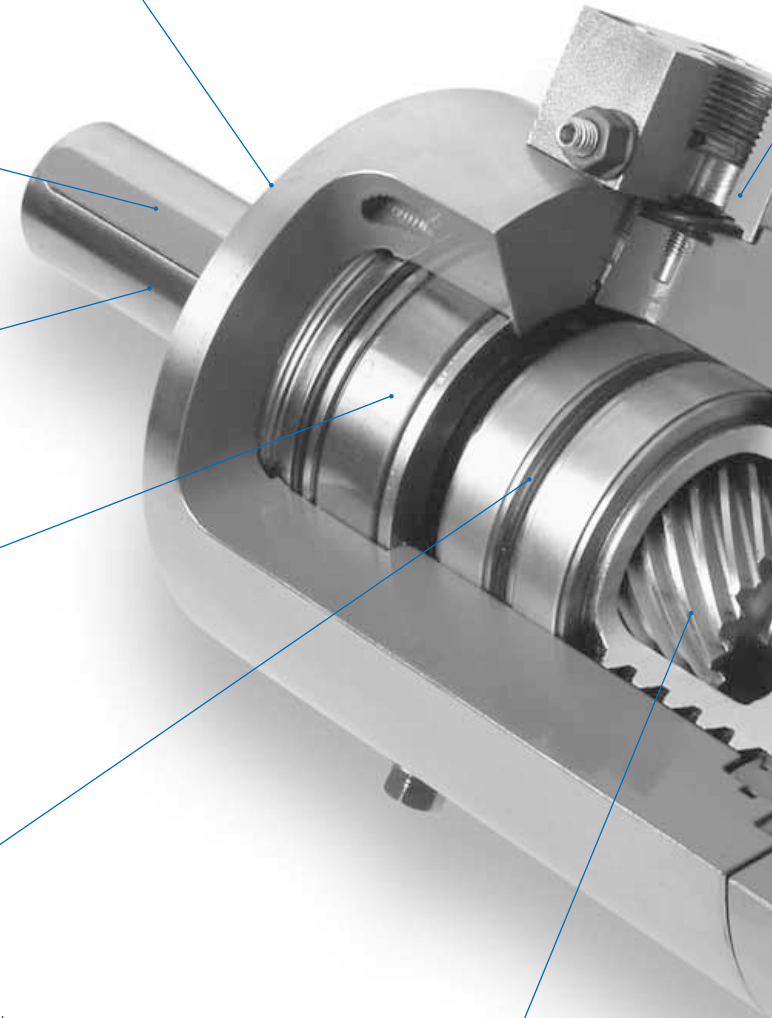

### wear-resistant moving parts

- long service life of the rotary actuator through extended-period nitriding
- excellent sliding characteristics of the gears

## highly perfected end cushioning for absorption of kinetic energy

- negating the need for expensive proportional or servo controls with virtually identical characteristics

## large-area press-fit joint

- assuring positive power/torque transmission even at peak load conditions

## ... over time

- short delivery times through flexible storage
- individual solutions for your product
- quality assurance according to DIN EN ISO 9001

## from 10 bar economically applicable

- through precise combined helical gears and low friction seals, is the E1 already from 10 bar economically applicable

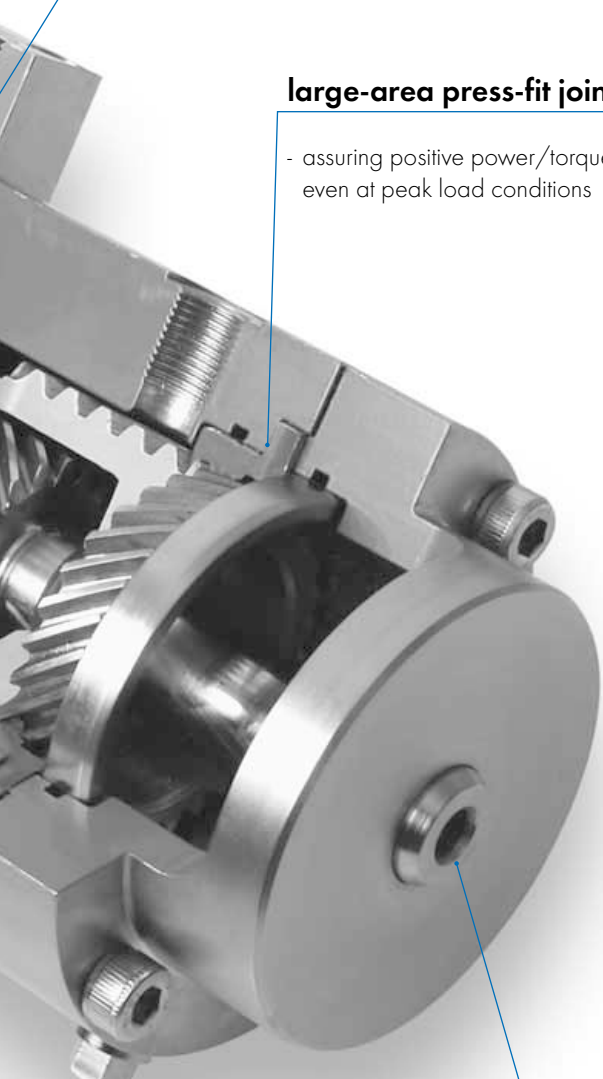

## through shaft

- the axial force required for mounting the shaft on the hub can be exerted at the end of the shaft, preventing destruction of the ball bearing
- the mounting of components for the pivoting angle monitoring is possible without problems

## Contents

Features E1	2, 3
Function and features	4, 5
Modular down to the tiniest details	6, 7
End cushioning	8
Options	8, 9, 10
Technical data and information	11
Dimensions	12, 13
Important technical information	14
Size and hazard analysis	15
Applications	16

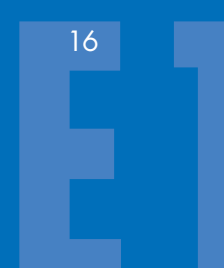

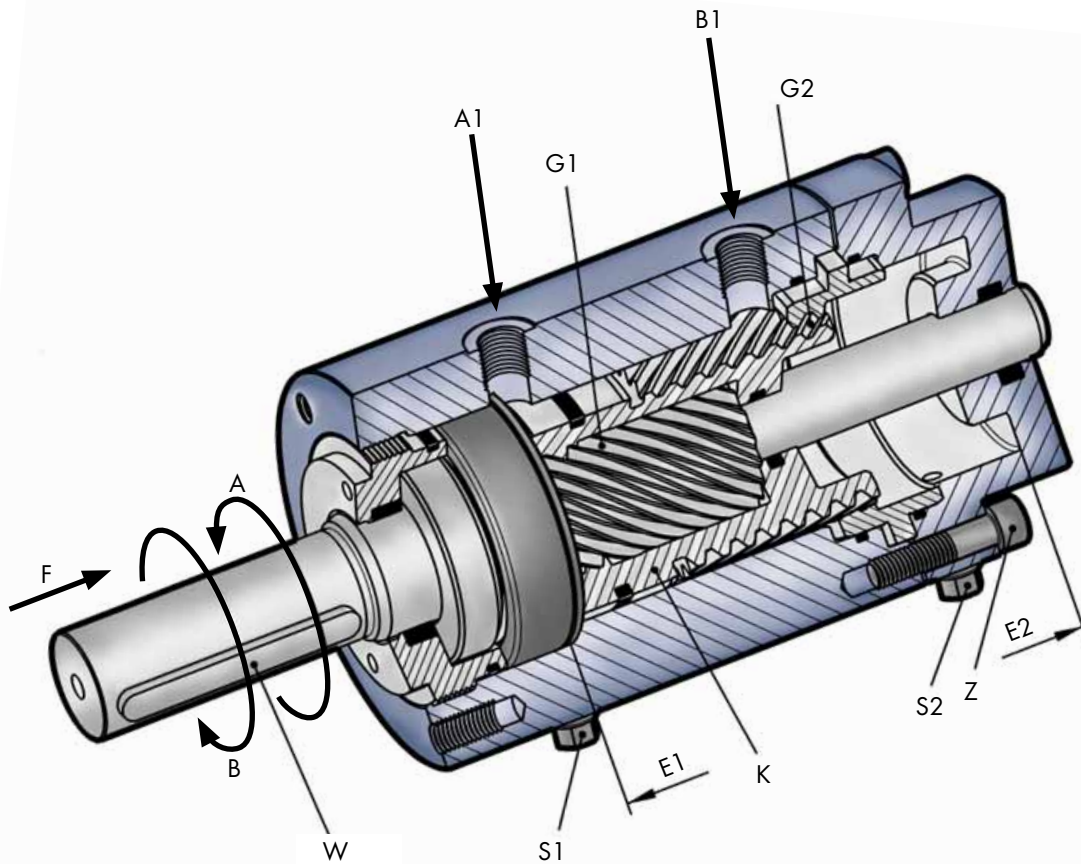

figure-2

### [ Operation ]

The rotary actuator E1 is used for rotating or turning useful loads.

As in a hydraulic cylinder the piston K (fig.-2) is moved in a linear motion between the two mechanical end positions E1 and E2 by means of hydraulic power.

Through the multiple helical gears the linear motion is mechanically transformed into a turning motion and transferred to the drive shaft W.

The opposed direction of the helical gears G1 and G2 causes a simple stroke of the piston to produce a doubling of the angular movement.

The pairs of helical gears are not self-inhibiting. Positive lubrication and nitriding of the surfaces of the helical gears ensures a long service life of the rotary actuator.

### [ Operating pressure ]

The maximum operating pressure of the rotary actuator is 100 bar. Low friction seals allow the rotary actuator to operate from as low as 5 bar operating pressure and so can be economically set at approximately 10 bar.

For especially slow rotation stick-slip seals can be supplied as a special specification.

### [ Drive shaft datum ]

The drive shaft datum can be adjusted within the angular minute range. After loosening the screws Z (1/2 turn), any drive shaft or key position can be adjusted. Once the required adjustment has been made, tighten the screws Z again as instructed (see manual).

The drive shaft datum is adjusted at the factory as shown in fig.- 2, with the piston K resting against the stop E1 (also see pages 12 and 13).

### [ Torque output ]

The stated torque figures are effective torques, with the pressure versus the torque curve being virtually linear. For multi-shift, heavy duty or high frequency applications a safety factor between 1.2 and 1.5 is recommended. Torque output is equal in both directions.

## [ Shaft rotation ]

From view F, the drive shaft W will rotate anti-clockwise (arrow A) when pressure is applied to port A1. A different direction of rotation is available as a special feature.

## [ Rotation ]

Standard rotations are 90°, 180°, 270° and 360°. Other rotations can be supplied on request by using the model with the next standard rotation up and limiting the stroke of the piston in accordance. Also available are special models with rotations in excess of 360°.

## [ Backlash ]

In order to function, the set of helical gears require a certain backlash of approx. 20 angular minutes. On special request, the rotary actuator can also be supplied with a reduced backlash of as little as 5 angular minutes.

## [ Fluids ]

We recommend mineral oil based hydraulic fluids of the group HLP as per DIN 51524 / Part 2 and VDMA recommendation 24318. Fluids without emulsifying agents reduce the service life of the rotary actuator. For heavily flammable fluids, please consult factory. The recommended viscosity range is 16 cSt to 68 cSt at 40° to 60° C.

## [ Operating temperature ]

The operating temperature can range from -25° C to +70° C, providing suitable fluids with the correct viscosity rating are used. Please contact us for any applications outside these limits.

## [ Oil change ]

The oil change depends on the size of the system and should be carried out at regular intervals.

## [ Filtration ]

The hydraulic fluid used in the rotary actuator does not exceed the pollution classification 19/15 in accordance with ISO 4406. Therefore, a filter setting of < 25 µm should be installed in the pressure line. With hermetically sealed containers a return filter should suffice. With open containers a pressure filter must be installed in the compressed air line. The maintenance intervals described above should be adhered to in line with manufacturer specifications.

## [ Leakage ]

The use of solid seals reduces leakage to the absolute minimum, therefore allowing the load to be held in any intermediate position.

## [ End of stroke ]

The piston K (fig. 2) can be moved under load against the end stops E1 and E2 and be loaded in this position.

The end stops are designed to withstand the force created by the maximum allowable operating pressure relating to the maximum permissible torque output.

If higher forces can be expected, we recommend installation of external stops or other methods of control such as end cushioning (see page 8 and 14) or control valves.

## [ Installation, maintenance and running in ]

An operating instruction for the installation, maintenance and running in are provided with every delivery.

Spare-part-list as well as dismantling and assembly instruction are available by request.

## [ Non-standard options ]

In addition to the options listed in this catalogue, special features can also be supplied. A few ideas are listed on pages 6 and 7. Please contact our engineers for further information.

### [ Extras which give flexibility ]

Successful companies gain competitive advantage, both for themselves and their customers, through innovative ideas and technologies. On the basis of E1, we have achieved special designs which are tailored precisely to your needs.

Please feel free to call us - our engineers and technicians will be pleased to help you.

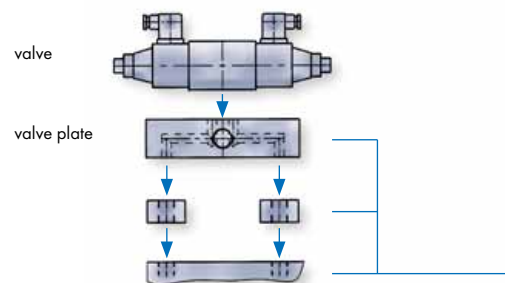
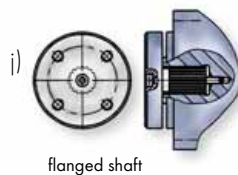
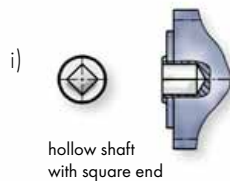
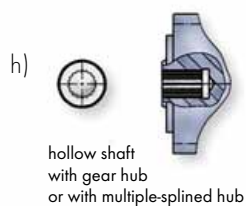
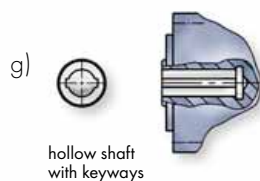
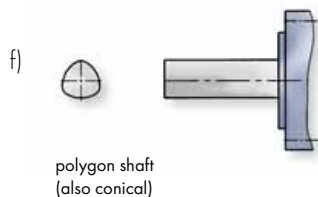
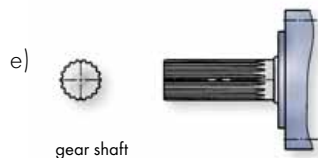
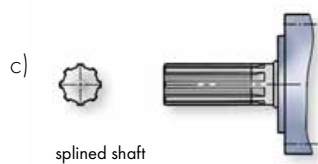
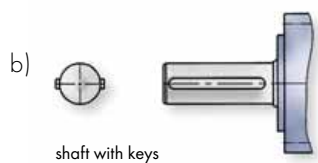
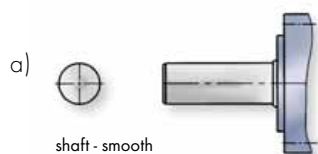

basic model

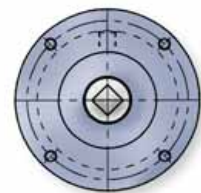
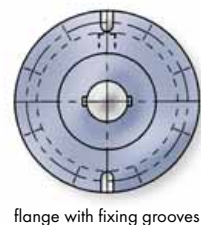
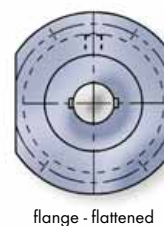
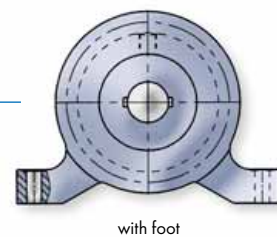
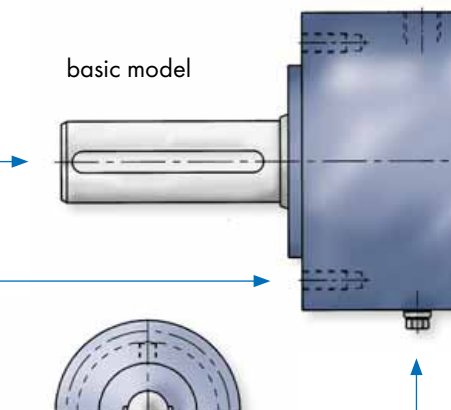



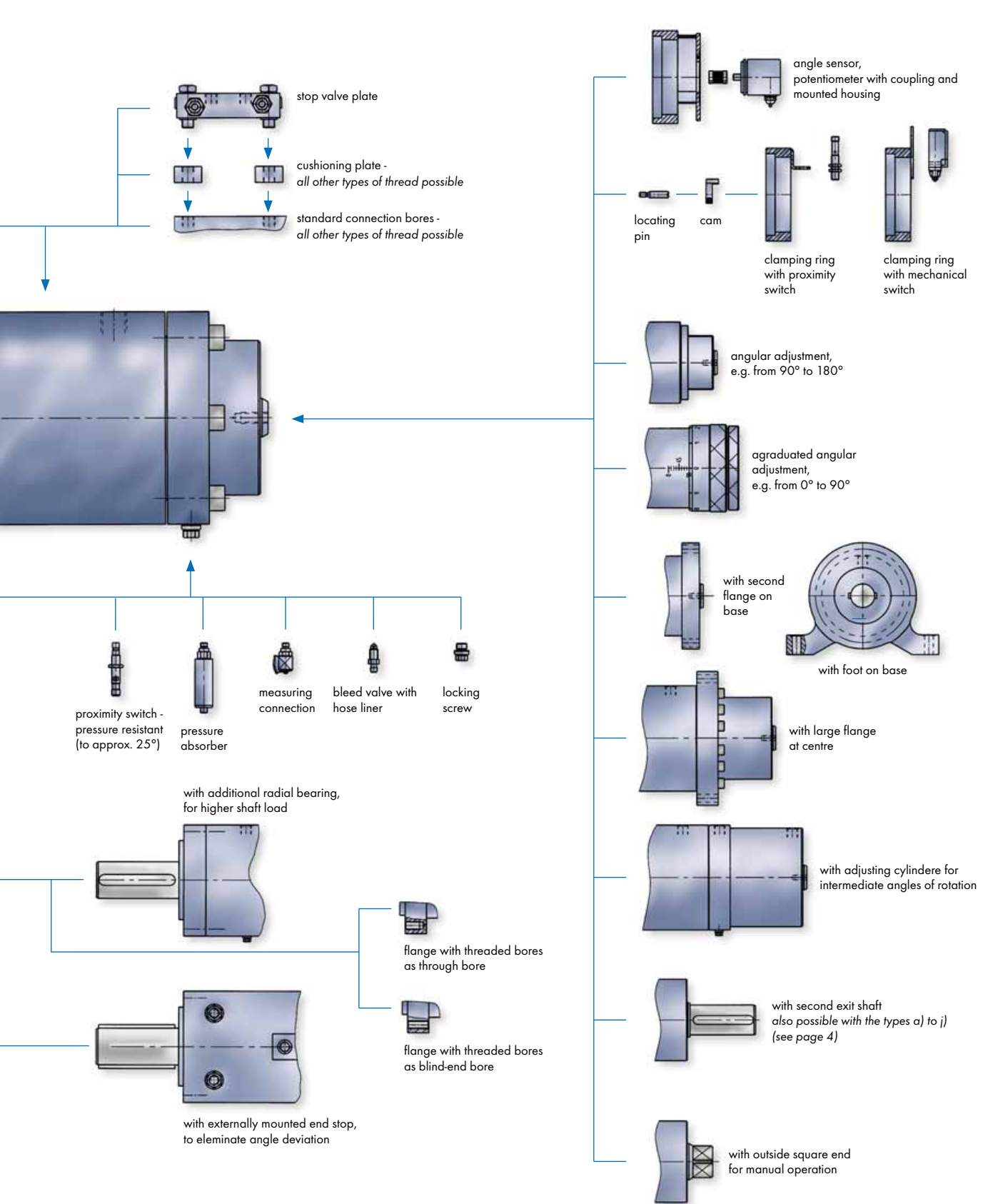

### [ Z1- End cushioning ]

End cushioning is aimed at dissipating and/or decelerating the rotary movement before the final end stop.

Eckart end cushioning is designed to meet the toughest requirements in modern hydraulics. On the basis of continuous research and development as well as close co-operation with our customers, we can offer you state-of-the-art end cushioning.

- You do not need to include any expensive proportional or servo controls in order to dissipate kinetic energy, because Eckart end cushioning will perform this function almost identically.
- Eckart end cushioning largely prevents pressure peaks, which often destroy rotary actuators with conventional single-stage cushioning or throttle regulation (see diagram in fig. 3)

### [ Operation ]

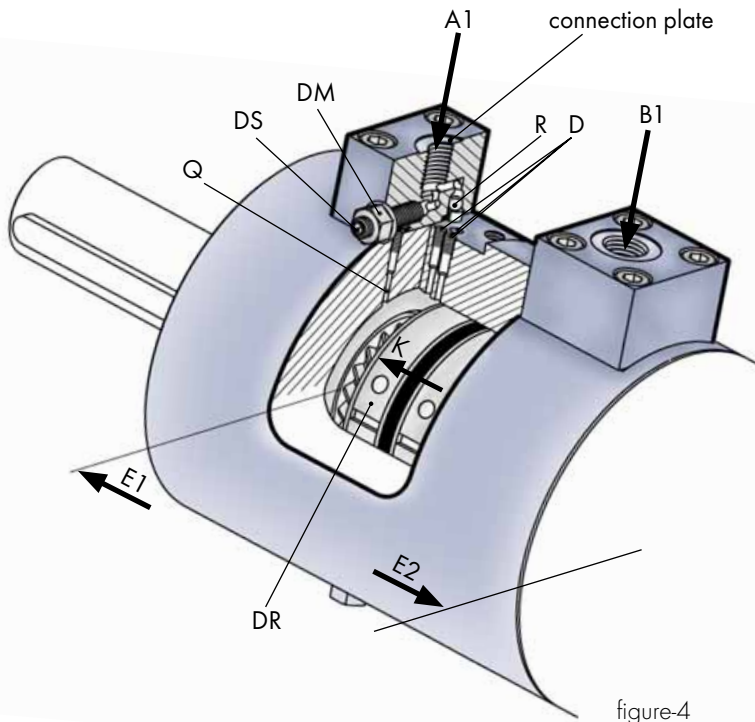

figure-4

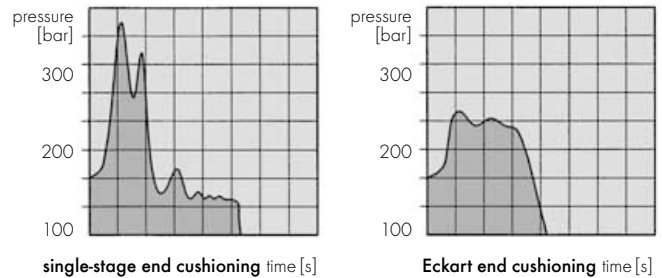

figure-3

The diagram shows one of the advantages of Eckart end cushioning over conventional cushioning with single-stage control

- The standard effective cushioning range in the end position is approx. 10° for all sizes. Other cushioning can be supplied on request.
- It is possible for the customer to adjust the cushioning effect individually by screwing in nozzles.
- End cushioning Z1 can also be delivered for each special angle of rotation (see too page 14).

#### A. Starting position

- piston K is in end position E2
- port A1 is pressurised
- port B1 (without connection plate drawn) is unpressurised

#### B. Reversing the directional control valve

- port B1 is pressurised
- ball check valve R in port B1 opens
- hydraulic fluid flows freely into the cylinder space
- piston K moves in the direction end position E1 (direction arrow piston K)
- ball check valve R is closed in port A1
- pressure medium flows off freely through the bores D

#### C. Cushioning process

- piston K now approaches the end position E1 and seals the bores D one after the other
- piston speed is progressively reduced
- piston K now completely covers the bores D
- pressure medium can now only escape through the bore Q with the adjusting screw DS to the port A1
- the cushioning effect can therefore be adjusted again by the adjusting screw DS
- the cushioning phase linear

Dimensions see page 12



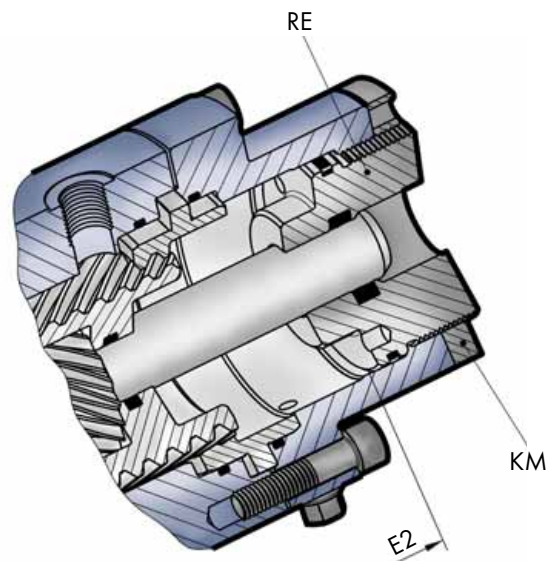

figure5

### [ Z2 - Externally adjustable end stop ]

The end angle can be re-adjusted at any time by  $\pm 5^\circ$ . In conjunction with the adjustable drive shaft datum, it is therefore possible to adjust the initial and final position of the total angle required. For adjustment, you only have to loose the counter nut KM. After this, you can reach the wished rotating angle through screwing in or out of the adjusting insert RE. A positioning is only possible, in the state of no pressure.

### [ SM1 - Replaceable with SM1 ]

The Eckart E1 is the successor of the classic SM1 which was build for over 30 years and was used for over 100.000 times. We attach a lot of importance by the development concerning the reducement of the dimensions at the same time for the replacement to the SM1. With this option is the replaceability warranted.

### [ Z4 - Long-range adjustable end stop ]

The angle of rotation can be adjusted individually with this option, both over its total range of rotation and over a partial range (e.g. total angle  $270^\circ$ , desired partial adjustment of  $180^\circ$  to  $270^\circ$ ). To this end, the adjusting insert RE is simply screwed inwards or outwards to give the desired angle of rotation. The shaft goes all the way through, allowing control equipment to be fitted. Adjustment is only possible in the unpressurised state. The long-range externally adjustable end stop Z4 is similar as shown on picture 5 and does only build, concerning the wished adjustable range longer (see too page 14).

### [ FL - Flange design ]

The E1 can also be delivered with a flange instead of the tapped holes at the front surface. The flange is mounted on the front surface holes.

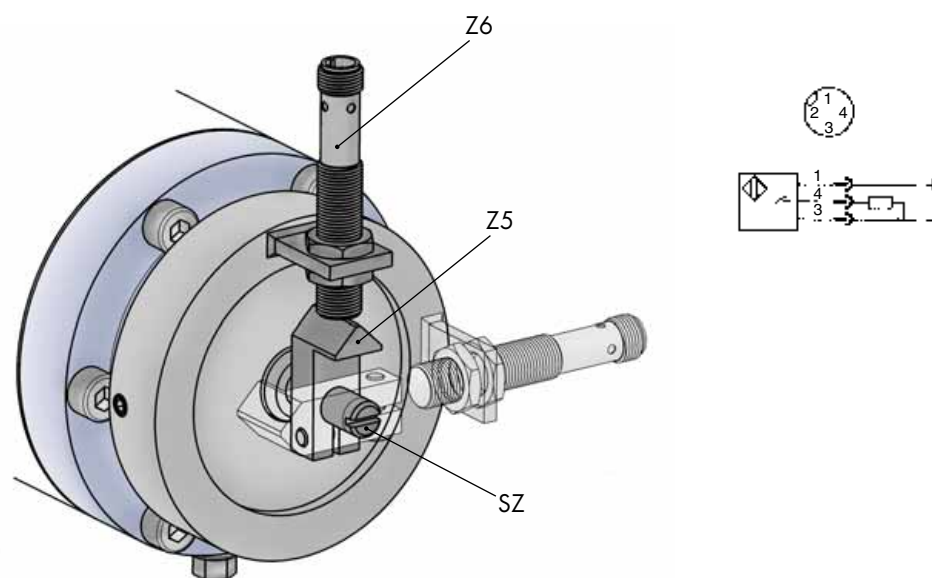

figure-6

### [ SZ - Locating pin ]

The locating pin SZ (fig. 3) is intended for the fitting of cams Z5 or other control equipment. It simply screws or is glued into the tapping provided at the back end of the shaft. It can be supplied at a later stage without reconstruction of the rotary actuator. The locating pin should not be used for torque transmission or for limiting the angle of rotation.

### [ Z5 - Cam ]

The cam Z5 (fig. 3) is clamped onto the locating pin SZ and is used to operate the control switches. If two cams are fitted, the second one is reversed and fitted upside down, while both cams remain individually adjustable.

### [ ZW - Gear shaft DIN 5480 ]

The gear shaft profile DIN 5480 is preferable to the standard key connection if high alternating and bending loads are expected. The profile and assembly dimensions are given on page 13.

### [ Z6 - Control switch assembly ]

This option allows the respective end positions to be touchless and electronically confirmed and the intermediate angles to be recalled. The locating pin SZ and the cam Z5 are included in this option.

Also the mounting of a couple of control elements is possible, by this will only get the amount of the elements higher (for example 2xZ6).

#### Technical data Z6 - inductive(fig.-6):

control element:	PNP normally open M12x1
nominal control interval:	2 mm
operating voltage:	10 ... 30 V DC
current carrying capacity:	200 mA
connection type:	plug
permissible temperature:	-25°...+70°
system of protection:	IP 67

#### **Plugs are not delivered as standard!**

Concerning this we ask for your inquiry.

### [ ZN - Gear hub DIN 5480 (hollow shaft) ]

Rotary actuators with a gear hub profile as per DIN 5480 shorten the structural length of the total construction, or are used for if the customer's counterpart can not be provided with a hub. The profile and assembly dimensions are given on page 13.

**Dimensions see page 12 + 13**

## [ Technical data ]

Size (piston-Ø)		40	50	63	80	100	125	
max. torque at 100 bar	[Nm]	74	162	304	588	1275	2450	
spec. torque	[Nm/bar]	0,74	1,62	3,04	5,88	12,75	24,50	
angle of rotation		standard 90°/180°/270°/360° and any intermediate angle, even above 360°						
medium		recommended: mineral oil of group HLP/DIN 51524, page 2 and VDMA page 24318; others on request						
min. operating pressure required		5 to 10 bar						
max. allowable operating pressure		100 bar / higher on request						
installation position		as required, provided that adequate air bleeding is provided						
temperature range		- 25°C to +70°C / higher or lower on request						
absorption volume	[cm <sup>3</sup> /1°]	0,17	0,38	0,7	1,43	2,98	5,86	
max. admissible rotation time per 90° (without load)	[s]	0,13	0,18	0,24	0,26	0,43	0,55	
weight [kg] ca. By the female construction is the weight about 7 % less.	angle	90°	4,0	6,5	10,0	13,7	23,8	39,0
		180°	4,6	7,5	11,8	16,4	29,0	48,0
		270°	5,2	8,5	13,6	19,1	34,2	57,0
		360°	5,8	9,5	15,4	21,8	39,4	66,0
max. radial load F <sub>R</sub>	[kN]	0,589	1,864	3,434	7,358	8,829	11,772	
max. axial load F <sub>AE</sub>	[kN]	1,472	2,453	4,905	8,829	11,772	17,658	
max. axial load F <sub>AA</sub>	[kN]	0,245	0,392	0,589	0,758	1,117	1,472	

## [ Important technical information ]

- Adherence to the data provided here is a precondition for trouble-free operation.
- The regulations of the Technical Supervision, Social Insurance Against Occupational Hazards and the respective environmental regulations etc. must be observed.
- Plant driven by a rotary actuator must be laid out in such a manner that in case of technical or human failure there is no danger of injury or death.
- We reserve the right to alter or improve design specifications without prior notice.

## [ Ordering code ]

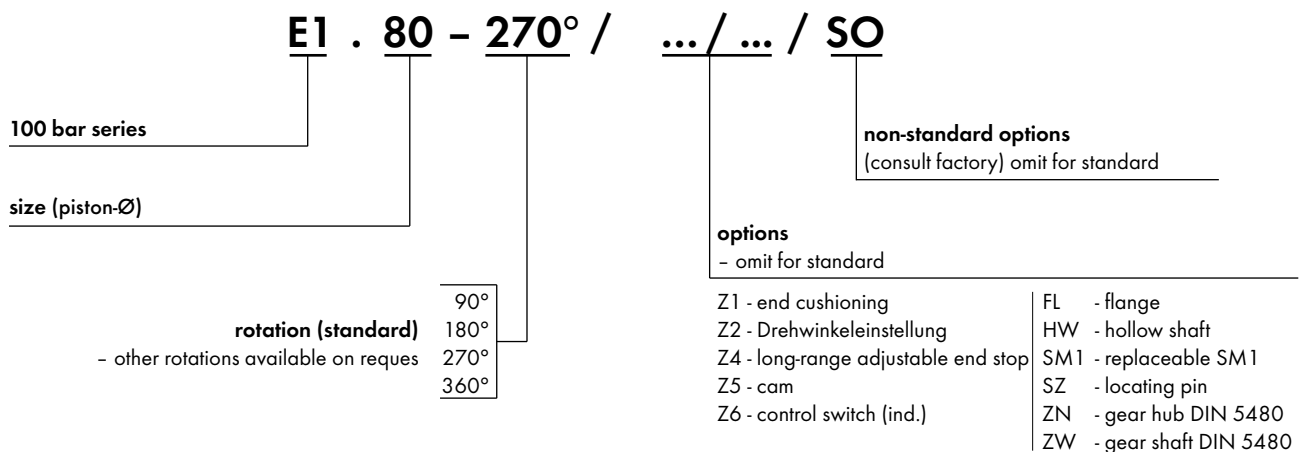

[ Standard model - size 40 - 125 ]

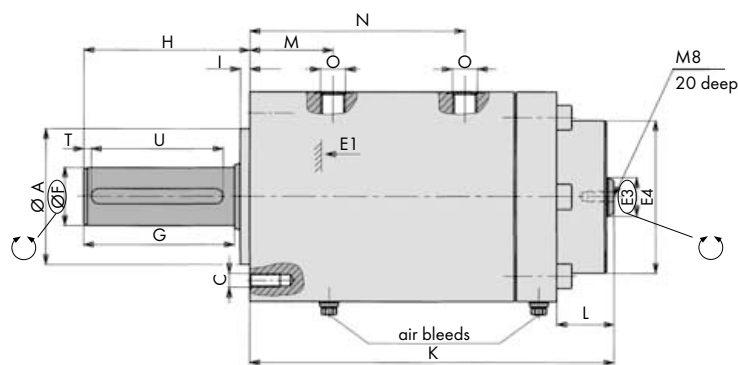

[ Locating pin - SZ ]

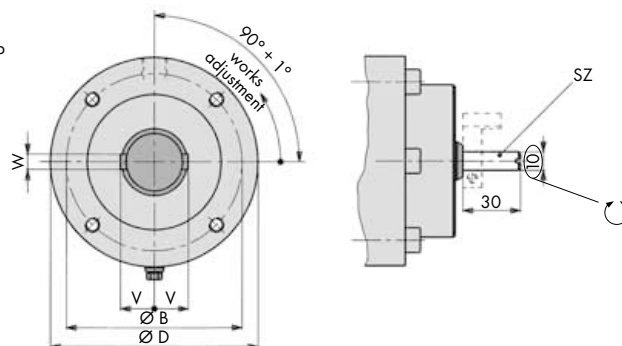

[ Model with hollow shaft - HW ]

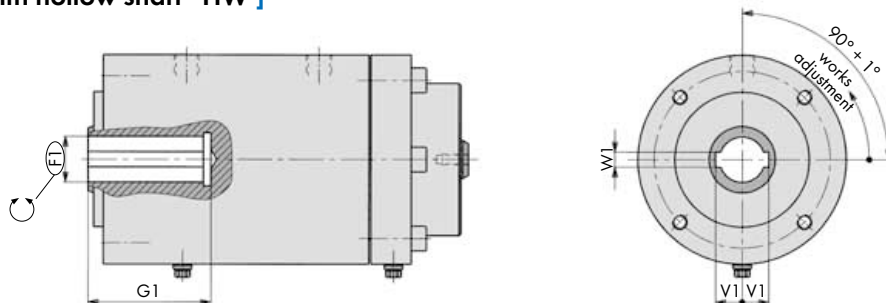

[ Model with end cushioning - Z1 ]

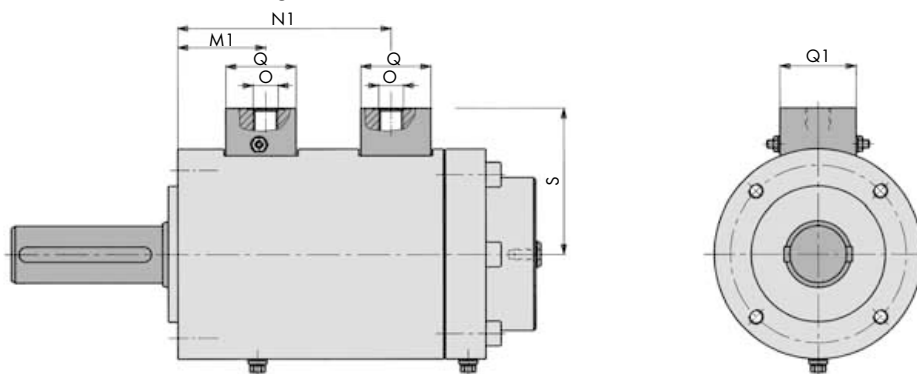

[ Comments ]

- 1) Dimension varies for models including option Z4 = adjustment of angle of rotation. Please consult factory.
- 2) max. length screwed out state
- 3) Depth as per DIN 6885, page 3

Order code on page 11

Size (piston-Ø)	Rotary actuator E1																																	
	øA	øA1	øB	øB1	øB2	C	øC1	øD	øD1	øD2	øE3	øE4	øF	øF1	G	G1	G2	G3	H	I	J	J1	K <sup>1)</sup>				K1				L <sup>1)</sup>			
	h7	h7				/Gew.depth							k6	H7										90°	180°	270°	360°	90°	180°	270°	360°	90°	180°	270°
40	45	40	65	90	73	M6/13	6,5	78	103	85	12	52	18	-	50	-	50	-	55,5	3	10	11	119,5	145,8	172,6	199,4	133	159,8	186,6	213,4	6	18,9	32,3	45,7
50	55	50	80	105	86	M6/13	6,5	93	118	98	12	62	25	-	60	-	60	35	67	4	11,5	11	135,6	169,1	205,1	241,1	147,6	183,6	219,6	255,6	8	23,5	41,5	59,5
63	65	60	93	125	102	M8/18	9	110	140	116	20	80	30	24	80	65	80	40	88	5	13,5	14	149	193	237	281	164,9	208,9	252,9	296,9	8,3	30,3	52,3	74,3
80	80	70	105	143	130	M10/20	11	123	163	150	20	92	35	30	80	85	80	45	89	6	14	18	172,8	226,8	280,8	334,8	190,2	244,2	298,2	352,2	17,5	44,5	71,5	98,5
100	105	80	130	168	143	M10/20	11	148	188	160	28	116	45	45	110	102	110	55	120	6	17	20	205,5	277,1	348,7	420,3	226,5	298,1	369,7	441,3	25,4	61,2	97	132,8
125	125	100	155	200	182	M12/24	13	177	225	205	32	140	60	55	140	120	140	60	152	7	19,5	21	237,4	327,4	417,4	507,4	260,2	350,2	440,2	530,2	34,6	79,6	124,6	169,6

[ Model with flange - FL ]

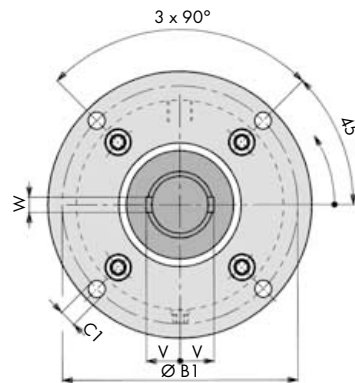
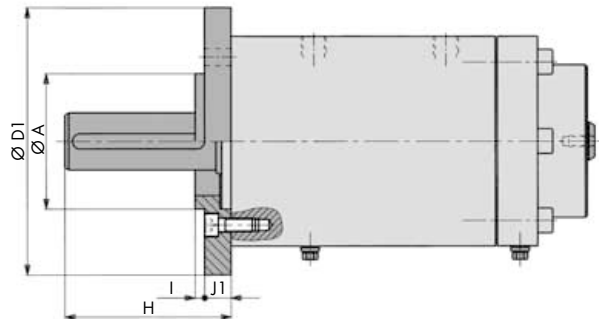

[ Externally djustable end stop - Z2 ]

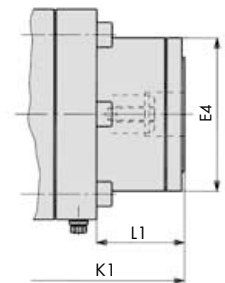

[ Replaceable - SM1 ]

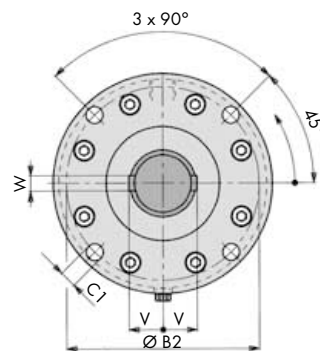
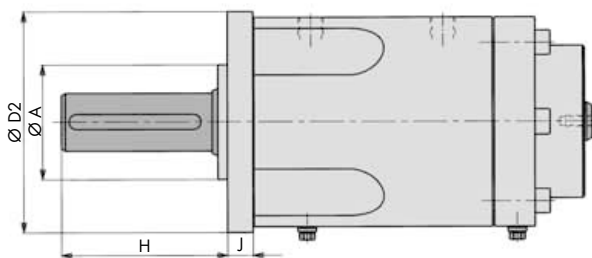

[ Cam - Z5 ]

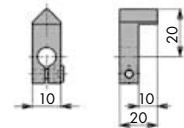

[ Model with gear shaft profile DIN 5480 - ZW ]

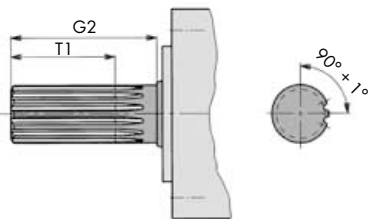

[ Model with gear hub profile DIN 5480 - ZN ]

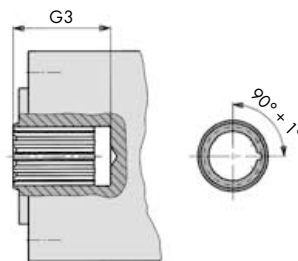

[ Control switch - Z6 ]

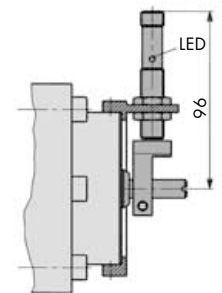

- We reserve the right to alter or improve design specifications without prior notice.

- Non-standard options on request

Rotary actuator E1																				ZW	ZN	Z6	Size (piston-Ø)					
L1 <sup>2)</sup>				M	M1	N				N1				O	Q	Q1	S	T	T1	U DIN 6885	V DIN 6885	V1 <sup>3)</sup> DIN 6885		W DIN 6885	W1 DIN 6885	DIN 5480	DIN 5480	b
90°	180°	270°	360°			90°	180°	270°	360°	90°	180°	270°	360°	port size														
19,5	32,9	46,3	59,7	35	38,3	75	88,4	101,8	115,2	71,8	85,2	98,6	112	G1/4"	37	40	60	1,5	35	45	11,5	-	6	-	W18x1,25 x13x8f	-	96	<b>40</b>
18	36	54	72	43	43,1	87	105	123	141	83,1	101,1	119,1	137,1	G1/4"	37	40	68	3	40	50	15,5	-	8	-	W25x1,25 x18x8f	N22x1,25 x16x9H	96	<b>50</b>
24,2	46,2	68,2	90,2	44	46,4	92	114	136	158	90,6	112,6	134,6	156,6	G1/4"	37	40	76,5	4	55	70	18	14	8	8	W30x2 x14x8f	N25x1,25 x18x9H	96	<b>63</b>
34,9	61,9	88,9	115,9	48	51	109	136	163	190	105	132	159	186	G3/8"	37	40	83,5	4	55	70	20,5	18,3	10	8	W35x2 x16x8f	N35x2 x16x9H	96	<b>80</b>
46,4	82,2	118	153,8	60	61	132	167,8	203,6	239,4	127,2	163	198,8	234,6	G3/8"	37	40	96,5	4	80	100	26	26,3	14	14	W45x2 x21x8f	N48x3 x14x9H	96	<b>100</b>
57,4	102,4	147,4	192,4	65	67	150	195	240	285	143,5	188,5	233,5	278,5	G3/8"	37	40	111	5	105	125	34	31,8	18	16	W60x3 x18x8f	N60x3 x18x9H	96	<b>125</b>

Because of its torque, angle of rotation, pressure range, positioning accuracy, stability of position, type of attachment and dimensions, the Eckart E1 rotary actuator can be used in a wide range of applications.

The selection and the size depends above all on the demands and the operating conditions under which the rotary actuator is operating. For the planning of special items, it is also important for us to be aware of all technical details.

### [ When planning the rotary actuator, we recommend the following ]

- The mechanical stops within the rotary actuator are designed to withstand the force created by the maximum allowable operating pressure relating to the maximum permissible torque output. If they are used to stop the load, the forces acting on them, including forces of inertia, must not exceed the force created by the maximum operating pressure.

If higher forces can be expected, we recommend installation of external stops or other methods of control such as end cushioning, as described below, or control valves.

- On hermetic locking of the rotary actuator (e.g. hydraulically controlled double release valves) and the impact of resetting force on the axle a holding pressure is generated. If the holding pressure reaches the level of the operating pressure there is a torque increase on the axle of 38 %. If resetting forces are expected this should be reflected in selecting the size of the rotary actuator. This also has to be taken into consideration in those cases of operation in which the optional end cushioning Z1 is used.
- In order to guarantee a fresh supply of pressure fluid or medium, the pressure connection lines should be kept as short as possible, and/or the directional control valve should be mounted directly onto the rotary actuator. If this is not possible, we recommend a hydraulically controlled double release valve with additional tank line.
- On hermetic locking of the rotary actuator (e.g. hydraulically controlled blocking valves) and the impact of heat from external sources it should be considered that the hydraulic pressure in the rotary actuator increases by about 6-8 bar per 1°C increase of the temperature. In case of substantial temperature increase the rotary actuator could be destroyed. If operating conditions with substantial temperature increases are expected, appropriate protective measures (e.g. safety valves, cycles of operation) should be provided.

In order to provide this we have prepared a catalogue of questions on page 15 which you can fax us if any lack of clarity emerge. Our staff will be glad to work out and submit a proposal to you.

We accept no guarantee claims for disturbances in functioning or complaints which are attributable to lack of information by the customer.

- During installation, care should be taken that the drive shaft or hub is perfectly aligned with the counterpart, since otherwise the maximum permissible radial and axial forces can easily be exceeded.
- In case of externally adjustable end stop Z2 on actuators with the end cushioning option Z1, the cushioning effect on the bottom side should also be changed.
- By the combination of both options long-range externally adjustable end stop Z4 and end cushioning Z1 is the building of the bottom end cushioning not possible.
- Ensure that air bleeding S1/S2 is accessible (important in the case of end cushioning Z1)
- The rotary actuator needs to be dismantled when changing replacement parts. It is therefore necessary to allow enough clearance for this to be carried out easily.
- In case of rotary actuators with the end cushioning option Z1, the flowing back of the pressure medium is progressively throttled down which causes the hydraulic pressure to rise on the cushioned side of the piston. In this context it must be ensured that the anticipated cushioning pressure does not exceed the operating pressure maximally admissible. As not all factors can be exactly pre-determined, not all requirement profiles can be implemented in configurations which use the end cushioning Z1. For this reason the details of the execution for the end cushioning Z1 must be established under all circumstances during the commissioning of the initial delivery of rotary actuators (we will be glad to assist you concerning this).

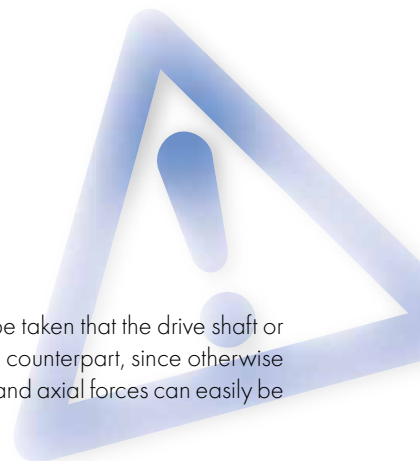



FAX to +49 (0)6661 9628-50

<b>ECKART GmbH</b> construction/sales department Am Knöschen 2 36381 Schlüchtern  Tel.    +49 (0)6661 9628-0 Fax     +49 (0)6661 9628-50 E-Mail  ek@eckart-gmbh.de	company name	_____
	department	name/ref. _____
	street	_____
	country/postcode/place	_____
	phone	fax _____
	e-mail	_____

date	project	no.
------	---------	-----

<b>We calculate for you!</b>		9	torque output	$M_d$	Nm										
		10	mass moment of inertia	$I$	kgm <sup>2</sup>										
		11	lever	$r$	mm										
		12	centre of mass	$R$	mm										
		13	mass	$m$	kg										
		14	reset power, holding power	$M_r$	Nm										
		15	radial load	$F_R$	N										
1	fitting position of rotary actuators				16	axial load	$F_{AA}$	N							
								17	axial load	$F_{AE}$	N				
	A	B	C	D	E	F	G	18	required working pressure	$P_A$	bar				
	options				19	maximum operating pressure	$P_B$	bar							
	Z1	Z2	Z4	Z5	Z6	FL	HW	SM1	SZ	ZN	ZW	20	pressure peaks	$P_S$	bar
	3				angle of rotation, max.				°	21	medium				
	4				angle of rotation, in operate				°	22	temperature of medium		°C		
5				rotation time, total	$t_g$			sec.	23	temperature of environment		°C			
6				cushioning time	$t_d$			sec.	24	volume flow	$Q$	l/min.			
7				cycle frequency	$T$			sec.	25	stops	<input type="checkbox"/> internal <input type="checkbox"/> external				
8				duration of operation per day				h	26	Z4 range of adjustment					
sketch/special features/ field of application/circuit diagram															

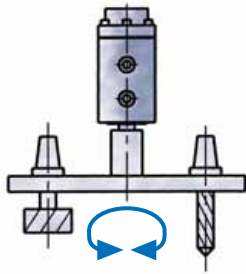

tool change

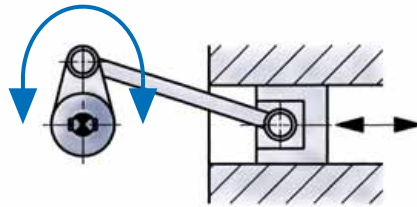

linear actuation

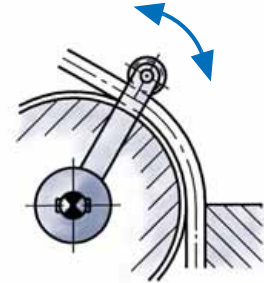

bending machines

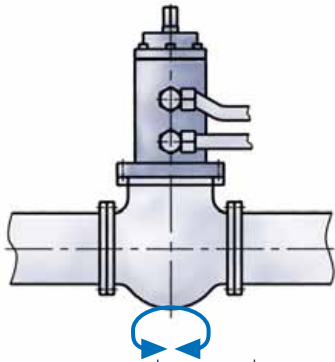

gate valve control

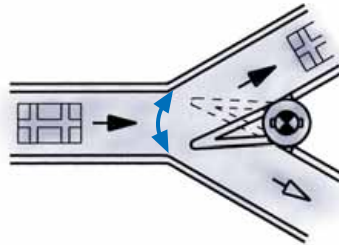

conveyor belts

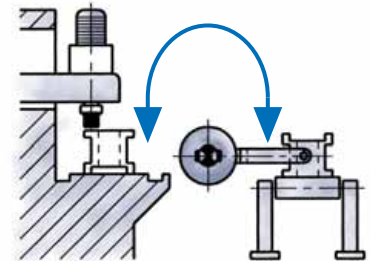

work piece positioning / changing

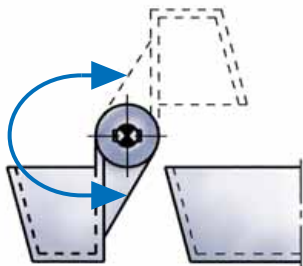

tipping devices

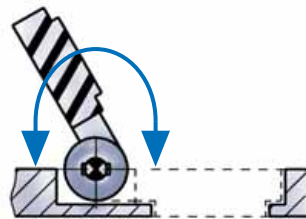

opening / closing

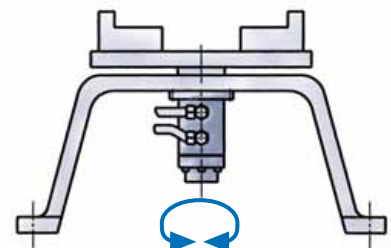

rotational devices