

Operation Instructions for the MP-F Pressure Intensifier

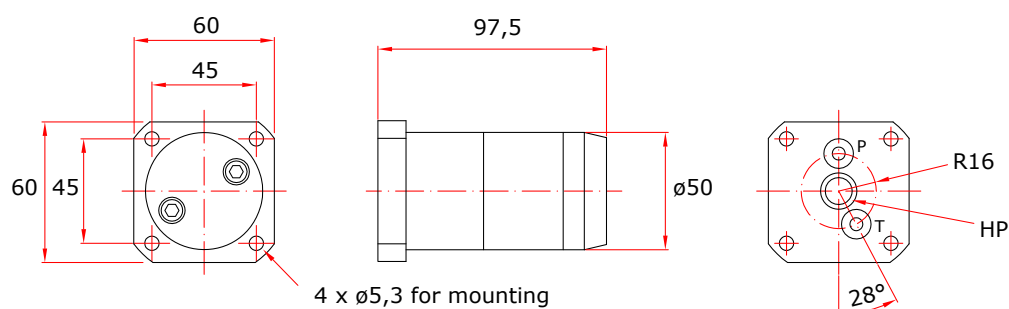

Before installing the intensifier

Ensure the surroundings and the connecting parts are clean and free from burrs.

Filtration requirements

10 μm nominal or better, maximum 19/16 according to ISO 4406

Seals

HP: Kantseal DKAR00014
P & T: O-ring 9,25x1,78 NBR90

Fluids

For use with standard hydraulic oils and water glycol (min. 5% glycol). Preferred viscosity range 20 - 46 cSt

Hydraulic bleeding

During start-up of the system, it is recommended to ensure no air is trapped in the system, as this may cause function problems.

Mounting to a customer block

The MP-F pressure intensifier is designed to be mounted on the side of a hydraulic block. The P and T ports are connected to A and B, and the discharge HP is providing higher pressure back into the block. The MP-F is fixated by 4 x M6 or similar sized screws

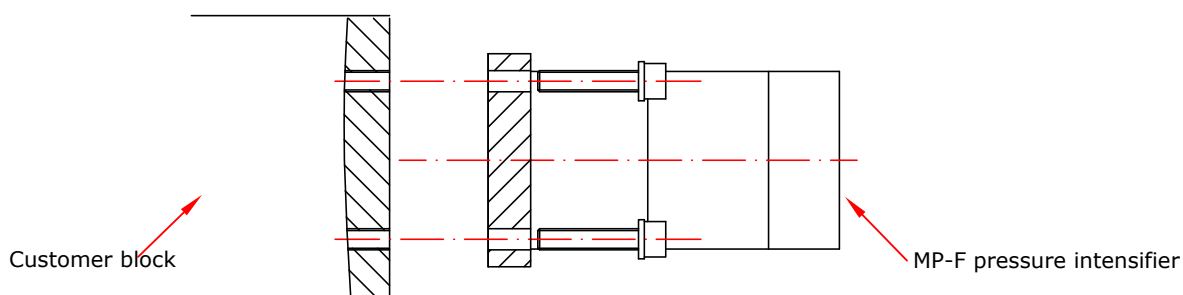

CAUTION:

Ensure the fittings and components on the output side are rated for the end pressure delivered by the Scanwill intensifier.

Function

The MP-F is a flange-on hydraulic pressure intensifier designed to increase a supplied pump pressure to a higher end pressure (for fluids only). The intensification ratio is fixed, and the end pressure is always proportional with the supplied pressure. Fig. 1 shows the schematic of the MP-F intensifier increasing the pressure in a single or double acting cylinder.

When applying flow to the P-port and connecting the T-port to tank, the full pump flow will go straight through the intensifier check valves CV1, CV2 and POV (optional) to the cylinder, allowing the rod to move out at pump speed. When the cylinder is filled up and the pressure has risen to pump pressure, the intensifier pistons automatically increase the pressure to the set end pressure. Keeping the pump connected ensures the intensifier will automatically work to maintain the end pressure in the cylinder, in case the pressure drops.

If the POV is integrated the cylinder can be retracted by connecting the P-port to tank and the T-port to pump. This will open the POV creating a free passage from the HP-side back to tank.

Fig.1

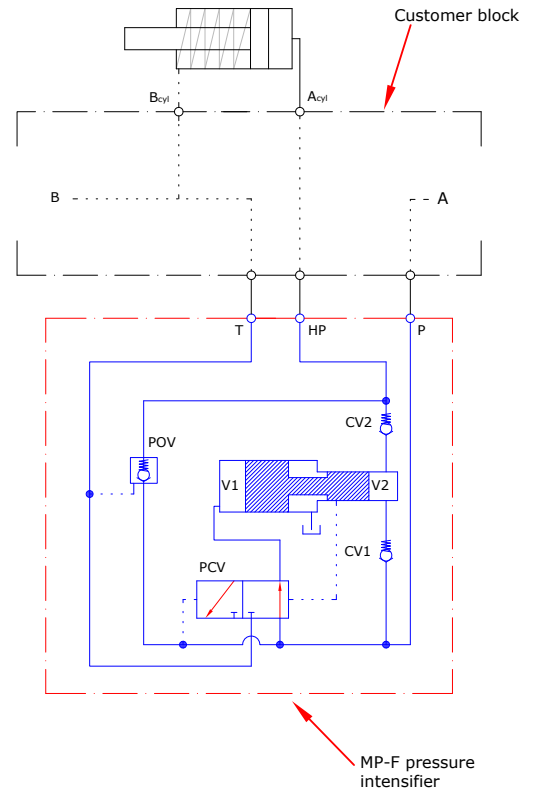

Intensification ratios, flow and pressure settings

Product number*	Intensification ratio	Max. supply Flow** (LPM)	Outlet supply pressure*** (bar)	Average outlet Flow**** (LPM)	Outlet pressure range***** (bar)
MP-F-1.5 / MP-F-1.5-S	1.5	15.0	200	0.3	30 - 300
MP-F-2.0 / MP-F-2.0-S	2.0	15.0	200	0.5	40 - 400
MP-F-2.8 / MP-F-2.8-S	2.8	8.0	200	0.3	56 - 560
MP-F-3.4 / MP-F-3.4-S	3.4	15.0	200	0.5	68 - 680
MP-F-4.0 / MP-F-4.0-S	4.0	14.0	175	0.4	80 - 700
MP-F-5.0 / MP-F-5.0-S	5.0	14.0	140	0.3	100 - 700
MP-F-7.0 / MP-F-7.0-S	7.0	13.0	100	0.2	140 - 700
MP-F-7.0 / MP-F-7.0-S	9.0	13.0	78	0.1	180 - 700

* S means intensification only, (no p.o. check valve POV is integrated)

** Max. supply flow limits not to be exceeded, as this will damage the internal check valves and over speed the intensifier pistons.
Min. supply flow is 2 LPM

*** Max. supply pressure limits not to be exceeded, as this will cause damage to the intensifier parts, and will cause to high outlet pressure.
Pressure spikes must be avoided.

**** The Average flow is the flow generated by the intensifier pistons when increasing the pressure from pump pressure to end pressure. Initially the flow is high, and as the pressure increases the flow decreases and will eventually stop when the end pressure has been reached.

***** The outlet pressure is proportional with the supplied pressure, and can be set at any value within the range.
The max. pressure within the range for each intensification ratio must not be exceeded

For additional technical support in North America, please contact your authorized distributor or IC-Fluid Power, Inc. for more information: sales@icfluid.com or +1.877.423.5843.