

JAHNS

HYDRAULIK

Flow divider designs

Edition 28.01

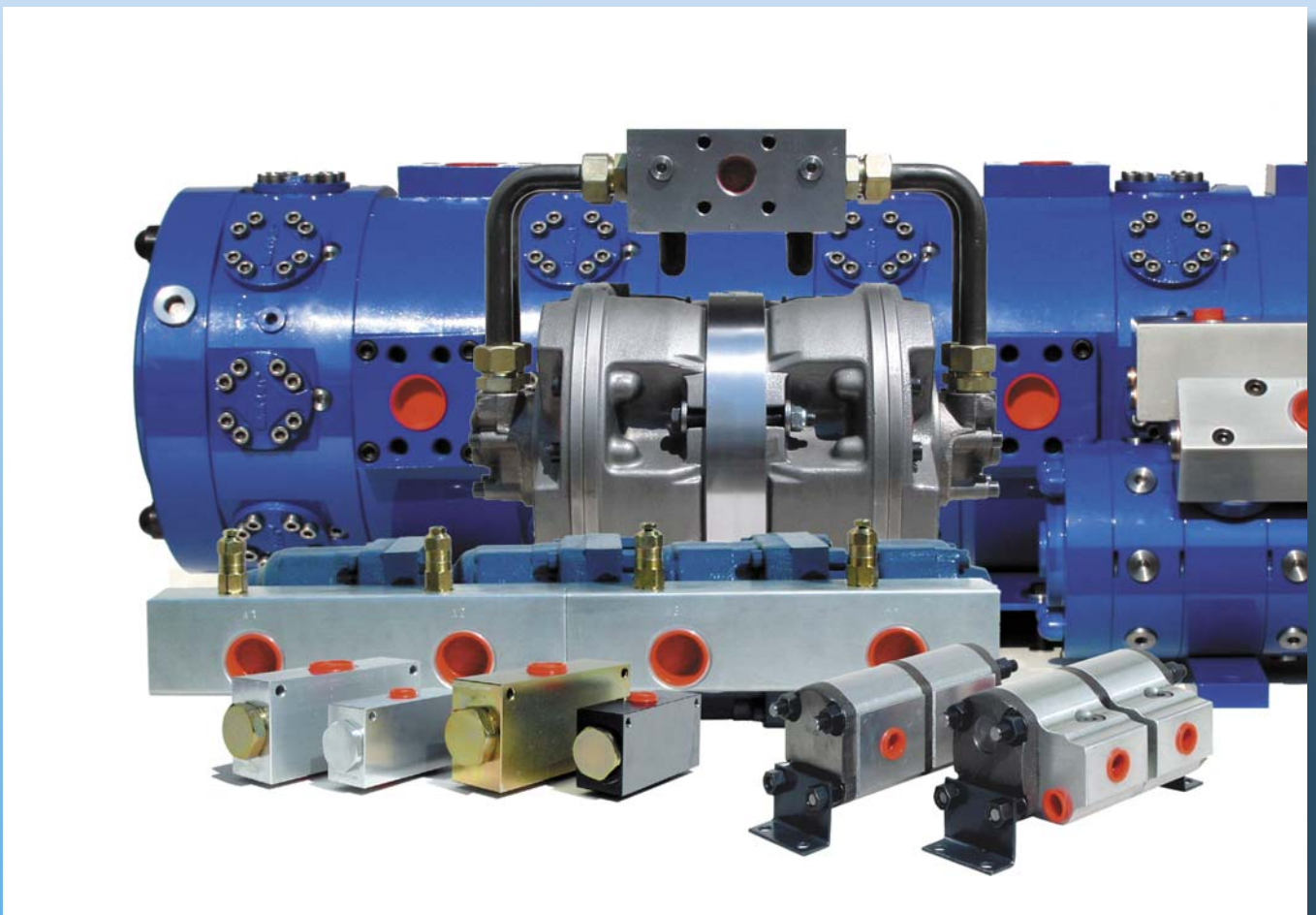

Jahns-Regulatoren GmbH

D 63069 Offenbach

D 63009 Offenbach

<http://www.jahns-hydraulik.de>

Sprendlinger Landstraße 150

Postbox 10 09 52

Telephon +49 (0)69 848477-0

Telefax +49 (0)69 84847725

info@jahns-hydraulik.de

Contents

Flow-divider applications

| | |
|---|---|
| Synchronised running | 3 |
| Pressure multipliers | 3 |
| Lubricating-oil flow divider | 3 |
| Synchronisation differences | 4 |
| Internal pressure-drop | 4 |
| Means of overcoming the pressure-drop | 4 |
| Using a "driver" | 5 |
| Compensating synchronisation-errors | 5 |
| Hydraulic fluids | 6 |
| Noise-levels | 6 |
| Applications limits | 6 |
| Synchronisation ratios | 6 |
| Synchronisation errors due to different oil-compression | 6 |
| Inlet/outlet-blocks | 6 |
| Use of other fluids than mineraloil | 6 |
| How to install the flow divider, start-up | 7 |
| Integral pressure valves | 8 |
| Installation instructions, Commissioning | 9 |

Technical data, dimensions

Series MKA, MKS, valves for 2 sections

| | |
|----------------------|--------|
| Size 1, size 2 | 10, 11 |
|----------------------|--------|

Series MTO, Aluminium housing, for 2 up to 12 sections

| | |
|--------------|--------|
| Size 0 | 12, 13 |
| Size 1 | 14, 15 |
| Size 2 | 16, 17 |

Series MTO, Cast Iron housing, for 2 up to 12 sections

| | |
|---|--------|
| Size 3, Inlet and Outletblock EA7 in aluminium | 18, 19 |
| Size 3, Inlet and Outletblock EA9 in steel | 20, 21 |
| Size 4, Inlet and Outletblock EA9 in steel | 22, 23 |

Series HTO, Cast Iron housing, for 2 up to 12 sections

| | |
|--------------|--------|
| Size 3 | 24, 25 |
| Size 4 | 26, 27 |

Series MT-GM, only 2 sections

| | |
|--|---------|
| MT-GM1 - MT-GM6, without Inlet/Outletblock | 28 - 30 |
| MT-GM1 - MT-GM6, with Inlet/Outletblock | 31 - 33 |

Series MTL and STL, for 2 up to 12 sections

| | |
|---|--------|
| MTL-../29 - MTL-../270, without Inlet/Outletblock | 34, 35 |
| MTL-../29 - MTL-../270, with Inlet/Outletblock | 36, 37 |
| STL-../220 - STL-../320, with and without Inlet/Outletblock | 38, 39 |

© Jahns Regulatoren GmbH 2004, 2005, 2006, 2007, 2009, 2010, 2011, 2014, 2016, 2017

Reprinting, even partially, not permitted.

No responsibility for possible errors in catalogues or other printed material is accepted.

Former catalogues lost their validity.

Catalogues are subject to be changed.

Flow-divider application

Synchronised running

If several motors or cylinders are operate from a single pump without any means of controlling their individual flows only the motor or cylinder with the lowest pressure requirement would start its work cycle. The motor or cylinder with the next lowest pressure requirement would only start when the first unit has completed its work cycle. This mode of operation is generally undesirable and it is therefore necessary for the total pump flow to be divided into a series of partial flows. This can be achieved in the following ways:

- Throttles or flow regulation valves in each of the motor or cylinders connections.
- Operating the units in a series circuit.
- With flow divider valves for 2 sections.
- With flow dividers of various designs.

Jahns flow dividers are of the rotating motor type and offer, independently of their design, the following synchronisation advantages:

- High degree of synchronisation even with the simpler gear-motor flow-dividers.
- High degree of synchronisation is maintained over a wide range of flows.
- Due to low leakage rates in the individual section the high degree of synchronisation is maintained with differing load conditions.

The use of flow dividers is not complicated if applied with an appropriate hydraulic circuit design. Additional installation alterations are not necessary.

For applications, where only a lower degree of synchronisation is necessary, Jahns offers flow divider valves, too. These valves are a very economic alternative. See page 8.

Pressure multipliers

As mentioned earlier as well as operating as a synchronising instrument the flow divider can be utilised as a pressure multiplier. The entire range of gear-motor flow dividers can be used for this type of application and due to their low internal pressure losses and low cost they often represent the optimal solution.

The cast-iron MTO range should be used when it is necessary to increase the output pressure to values around 280 bar. There is the option of requesting special versions with individual sections having varying absorption volumes. This enables pressures to be increased by a factor of three, four and more.

The pressure values in the example diagram below are indicative of an MT. The theoretical output pressure value of approx. 400 bar will be lower due to efficiency losses. It should be noted that the pressure gain achieved is made possible through an increase in system flow. This type of hydraulic circuit can be used where a low pressure circuit is already in use and where there is only need of small high pressure flow.

The installation of a supplementary high pressure circuit with pump, electric motor, pressure relief valve and manometer would not be convenient in this case as it would be possible to utilise the existing low pressure circuit.

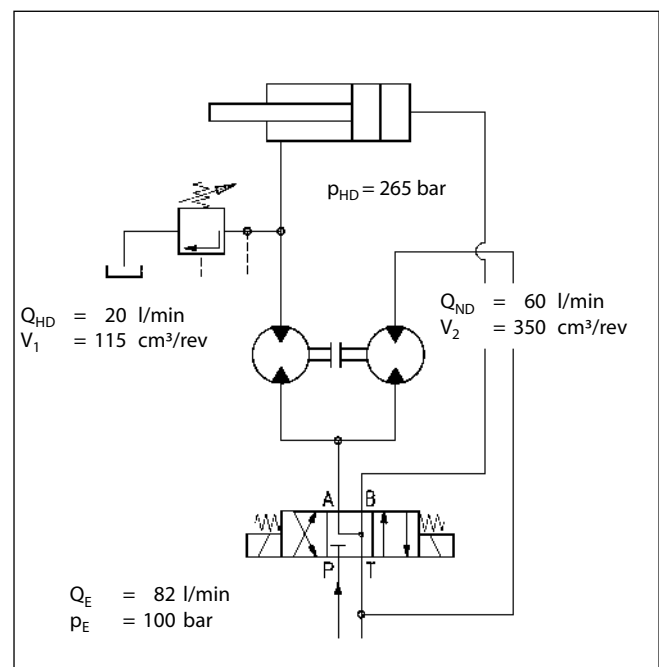

Lubricating-oil flow-divider

Shafts with multiple sets of friction bearings require a sure supply of lubricating oil in equal quantities to each of the bearings. With the gear-motor flow dividers, that do not have any external leakages, if the gear of one of the sections are turning then a synchronised flow in all the other sections is ensured. It is therefore only necessary to check the speed of one of the shafts with an electronic sensor and Jahns can supply the component required for this solution.

Flow-divider application

Synchronisation differences

With particular reference to the gear-motor flow dividers MTO but also for the radial-motor flow dividers MT-GM and MTL synchronisation differences depend on the following parameters:

- Oil viscosity and temperature
- Pressure load variability
- System pressure levels
- Total flow rate to be divided

Precise indications of synchronisation levels are only possible if the details of all the above parameters are known.

A general indication may be obtained from the following values:

MK under maximum oil-flow-values in the catalogue synchronisation tolerances $\pm 4,0$ up to $\pm 5,0$ %

MTO Size 0 (aluminium housing) synchronisation tolerances $\pm 2,0$ up to $\pm 3,0$ %

MTO Size 1 and 2 (aluminium housing) running more than 1200 rpm synchronisation tolerances $\pm 1,5$ up to $\pm 2,0$ %

MTO Size 3 and 4 (cast iron housing) synchronisation tolerances ± 3 up to ± 4 %

HTO synchronisation tolerances ± 3 up to ± 4 %

MT-GM synchronisation tolerances $\pm 0,5$ up to $\pm 0,8$ %

MTL synchronisation tolerances $\pm 0,5$ up to $\pm 0,8$ %

Jahns is able to carry out test-bench simulations of specified working conditions in order to determine the synchronisation levels of a customer's particular application. In this way it is possible for the customer to avoid incorporating large "safety margins" in the design.

Internal pressure drop in flow-divider valve.

You find the datas in the diagrams on page 10.

Internal pressure drop in gear-motor flow-dividers

Currently the decrease in pressure in the MTO series geared oil-flow dividers must be calculated based on the following pressure loss: 15-20 bar for size 2, 25-30 bar for size 3 and 30-40 bar for size 4. These values are respective to an initial pressure of 150-180 bar and a flow volume equating to 1200 revs./min.

If it is important for you to know the actual value, please enquire providing details as regards the respective pressure, oil flow-rate and oil viscosity.

Internal pressure drop in radial-piston flow-dividers

The radial piston motor design has larger pressure drops than the gear motor design and the pressure drop also depend on the outlet pressure. The following of the outlet pressure for all MT-GM an MTL models:

| Required output pressure (bar) | Input pressure (bar) | Pressure drop (bar) |
|--------------------------------|----------------------|---------------------|
| 50 | 60 | 10 |
| 100 | 120 | 20 |
| 140 | 175 | 35 |
| 150 | 190 | 40 |
| 180 | 225 | 45 |
| 190 | 240 | 50 |
| 210 | 265 | 55 |
| 230 | 285 | 55 |

Pressure drop in radial-piston flow-dividers MT-GM and MTL

Means of overcoming the disadvantage of pressure drop

- Often for cylinders the high pressure is only required in one flow direction. The flow divider can be built into the return line were the pressure is much lower.
- In several applications synchronisation is not required during the high pressure phase of the work cycle, for example, in a 2 cylinder press synchronisation is only needed when the cylinders are working at low pressure. During the high pressure phase of the work cycle the flow divider can be by-passed using check valves.

Flow-divider application

Using a “driver”

This is achieved by adding an extra section of equal or greater displacement to the flow divider. The return line of this section is connected directly to tank so that it in effect works as a motor for the other sections in the flow divider thereby increasing their outlet pressures. This is useful, for example, in lifting platforms that should lower under action of their own weight, but where the weight of the empty platform is insufficient for this to occur.

Compensating synchronisation errors - installation of the flow divider in the hydraulic circuit

As the flow divider is an independent flow control mechanism without any direct means of measuring the synchronisation errors that will always occur, any corrections have to take place as the cylinders reach the end of their stroke.

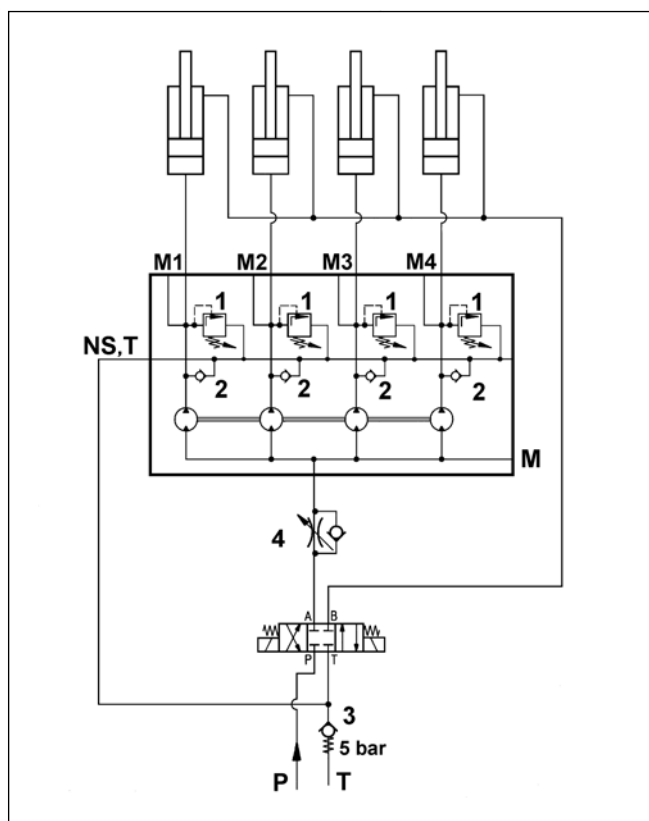

The diagram shows an example of such a circuit. The valves in the circuit have the following functions: The pressure relief valves **1** serve as protection against excess pressure in the cylinder outlet lines as may be caused by the pressure multiplier effect. In this way

all cylinders are able to complete their strokes even if one of them has reached the stroke-end. Valves **2** and **3** maintain a minimum pressure of approx. 4 bar in each of the flow divider sections. The difference of 1 bar from the opening tension of valve **3** is due to the opening tension of valves **2** of 1 bar.

The minimum pressure feed is important, for example, when one of the cylinder has reached its end stroke, but the flow divider continues running due to the slower cylinders. The pressure feed then prevents suction occurring in the line connecting the fastest cylinder. Valve **4** has an important function which is often ignored on flow dividers: If the oil flow from the pump reaches the cylinders and the flow divider has the task of collection the returnline oil in order to perform an equalisation of the flows, valve **4** ensures that the flow divider is not made to run at the speed of the fastest cylinder then the other cylinders do not follow due to friction, loading, pinching etc.: the flow divider can only operate as a collector if all the cylinders operate at the same speed.

A pressure relief valve or an over-centre valve could be used instead of the throttle valve **4**.

The use of such a valve in the circuit becomes particularly important when the cylinder return strokes occur without a controlling pump flow, eg. under action of their own weight.

Minimum flows

The gear flow-dividers in particular are not low speed components. Generally the minimum flows per section are as follows:

$$\text{MTO} : Q_{\min} (\text{l/min}) = V_{\text{Kammer}} (\text{cm}^3/\text{U}) \times 0.5$$

Bei den Radialstromteilern gilt:

$$\text{MT-GM} : Q_{\min} = 0.15 \times Q_{\max}$$

$$\text{MTL} : Q_{\min} = 0.25 \times Q_{\max}$$

Flow-divider application

Hydraulic fluids

Our flow dividers are designed to be used with mineral oil in accordance with DIN 51524.

The operating temperature range is fixed at -25°C to +80°C with normal seals and -25°C to +100°C when using Viton seals.

The recommended oil viscosity is between 12 and 100 cSt, while at start-up they are approved for maximum values up to 600 cSt.

Use of other fluids than mineral oil

Specially the radial-piston flow dividers, but the flow-divider valves, too, accept other fluids than mineral oil, such as HFC, HFD, non-contaminating fluids. Please contact Jahns in those cases.

Flow divider start-up

The smallest flow dividers in particular do not start if there is already a high outlet pressure at the beginning of the cycle.

This situation occurs, for example, with the flow divider installed between the pump and cylinders, when the lifting of a load is stopped and held by pressure in the flow divider outlet.

In this case it is possible to use check valves to hold the load while the flow divider outlets are relieved of pressure. Depending on the type of application a variety of solutions are possible; it is merely a question of taking this into consideration when designing the circuit.

Noise-levels

Specially the gear-motor flow dividers cause a noise-level running over 1800 rpm that can not always be accepted. Please choose the displacement according to this fact.

Synchronisation ratios

In general, the synchronisation ratio required is 1:1. Different ratios are possible on request. If so, please contact Jahns technical staff. Obtaining different ratios is made easier if it is possible to obtain the required section displacement difference in the same section housing.

Application limits

Due to the propensity of all flow dividers to leak oil it is not possible to keep the cylinders under pressure for an extended period of time. As a consequence it is necessary to fit pilot-operated non-return valves in every line between flow divider and cylinder.

Flow dividers are not able to compensate for the error (0.07% per 10 bar) due to differential oil compression at varying load pressures.

For very short stroke or cycle times and also for small cylinder volumes our MZB volume synchronisers are potentially a better solution. Please contact us for more information.

If you are considering the use of flow dividers but you are not sure whether using flow dividers will work, please contact us, preferably by sending us the intended circuit diagram. Due to our many years of experience working with our customers in this area, we will be able to provide you with the best possible application advice.

Synchronisation errors due to differing oil compression

The flow divider is not able to compensate for errors due to differing oil compression caused by differing cylinder loads. It is advisable to minimise oil volumes between the flow divider and the cylinder by using short tubes of equal length for all cylinders. If the difference in load in the cylinders is unchanging then it is possible to correct or eliminate oil compression synchronisation errors with the appropriate use of pressure relief valves.

Inlet / outlet-blocks

To achieve a minimum of piping and fittings and to guarantee the proved quality of important valves for the hydraulic circuit, you can get from Jahns so called inlet/outlet blocks for MTZ, MT and MTL flow divider. They have to be ordered directly together with the flow dividers, because a later assembly is generally impossible or causes problems. The blocks for the MT series are not separated into inlet/outlet ports, but integrated in one block only.

The present outlet-blocks have a relief-valve for each section and a separate port to measure the pressure. The pressure setting should be done, when the cylinder are in the external stroke-end. The pressure-setting should be 20 bar over the pressure to lift the cylinder with their charge. The port NS, T should be connected with the return-line. This return-line should have a pretension of 3-5 bar.

Integral pressure valves in the MTO

The pressure control valves are set to these values

The fact that the pressure valves are counter-sunk means that it is not possible to adjust them, whilst at the same time looking at the pressure manometer. In order to set the valves it is necessary to remove the pressure cartridge from the block. Since the safety valves need not be set to a great degree of precision and can easily accommodate a tolerance of 3 bar, it is possible to set the valve by simply measuring the distance 'L' using a calliper rule. In the diagrams (left) you can read off the values for pressure = f(L) for the different springs. These tables indicate the pressure levels and the corresponding spring lengths. After installing the pressure control valves again, the adjustment is completed.

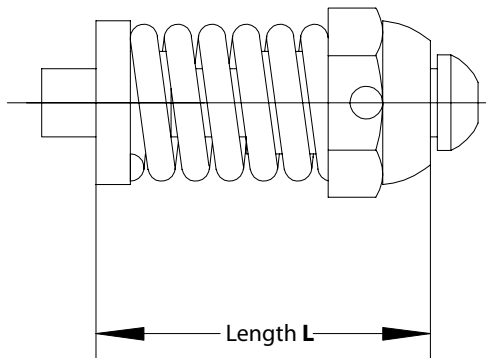

Standardspring, colour red, standard, preset to approx. 180 bar

| pressure (bar) | Length L (mm) | pressure (bar) | Length L (mm) |
|----------------|---------------|----------------|---------------|
| 130 | 27,50 | 220 | 26,15 |
| 140 | 27,35 | 230 | 26,05 |
| 150 | 27,20 | 240 | 25,90 |
| 160 | 27,05 | 250 | 25,80 |
| 170 | 26,90 | 260 | 25,65 |
| 180 | 26,75 | 270 | 25,55 |
| 190 | 26,60 | 280 | 25,40 |
| 200 | 26,45 | 290 | 25,25 |
| 210 | 26,30 | 300 | 25,15 |

Specialspring, colour green, preset to approx. 120 bar

| pressure (bar) | Length L (mm) | pressure (bar) | Length L (mm) |
|----------------|---------------|----------------|---------------|
| 90 | 26,80 | 150 | 25,70 |
| 100 | 26,60 | 160 | 25,55 |
| 110 | 26,40 | 170 | 25,35 |
| 120 | 26,25 | 180 | 25,20 |
| 130 | 26,05 | 190 | 25,00 |
| 140 | 25,90 | 200 | 24,80 |

Specialspring, colour blue, preset to approx. 100 bar

| pressure (bar) | Length L (mm) | pressure (bar) | Length L (mm) |
|----------------|---------------|----------------|---------------|
| 60 | 26,6 | 120 | 25,0 |
| 70 | 26,3 | 130 | 24,8 |
| 80 | 26,0 | 140 | 24,5 |
| 90 | 25,8 | 150 | 24,2 |
| 100 | 25,6 | 160 | 24,0 |
| 110 | 25,3 | | |

Specialspring, colour black, preset to approx. 50 bar

| pressure (bar) | Length L (mm) | pressure (bar) | Length L (mm) |
|----------------|---------------|----------------|---------------|
| 30 | 26,2 | 60 | 25,3 |
| 40 | 25,9 | 70 | 25,0 |
| 50 | 25,6 | 80 | 24,7 |

Flow-divider application

MTO Sizes 0 to 2

Aluminium housing. The different displacements of units within the same size are indicated by the width of the housing.

It is possible to interconnect flow dividers of any displacement listed in the tables. The same is also possible in terms of combining both component groups. This is important when they are used as pressure boosters.

The inlets to the individual chambers are interconnected internally. The number of connections on the inlet side must be based on the flow to be divided.

In version 'A' each section has a combined pressure relief and suction valve which is incorporated directly in the housing. Although the pressure relief valves are adjustable, they are concealed so as to prevent unregulated, operational adjustment. However, they can be adjusted should it be necessary to do so.

MTO Sizes 3 and 4

Cast iron housing. All Size 3 units have the same width of housing irrespective of displacements. The individual sections of the flow dividers are bolted together.

The flow dividers can also be supplied with inlet and outlet blocks.

MTO Size 3 EA7 (aluminium)
 EA9 (steel)

MTO Size 4 EA9 (steel)

If no inlet block is used, every inlet on the flow divider must be connected.

HTO Sizes 3 and 4

Cast iron housing. Irrespective of displacement there is only one width of housing in each range. The individual sections of the flow dividers are bolted together, which facilitates assembly and disassembly.

The operating pressure for the HTO is 320 bar.

The housing incorporates an inlet and outlet block. Couplings are used to connect the individual sections. The number of connections on the inlet side must be based on the flow to be divided.

In the case of the size 4 it is necessary to connect up at least every second connection.

Assembly-position of inputs and outputs MTO Size 1 and 2

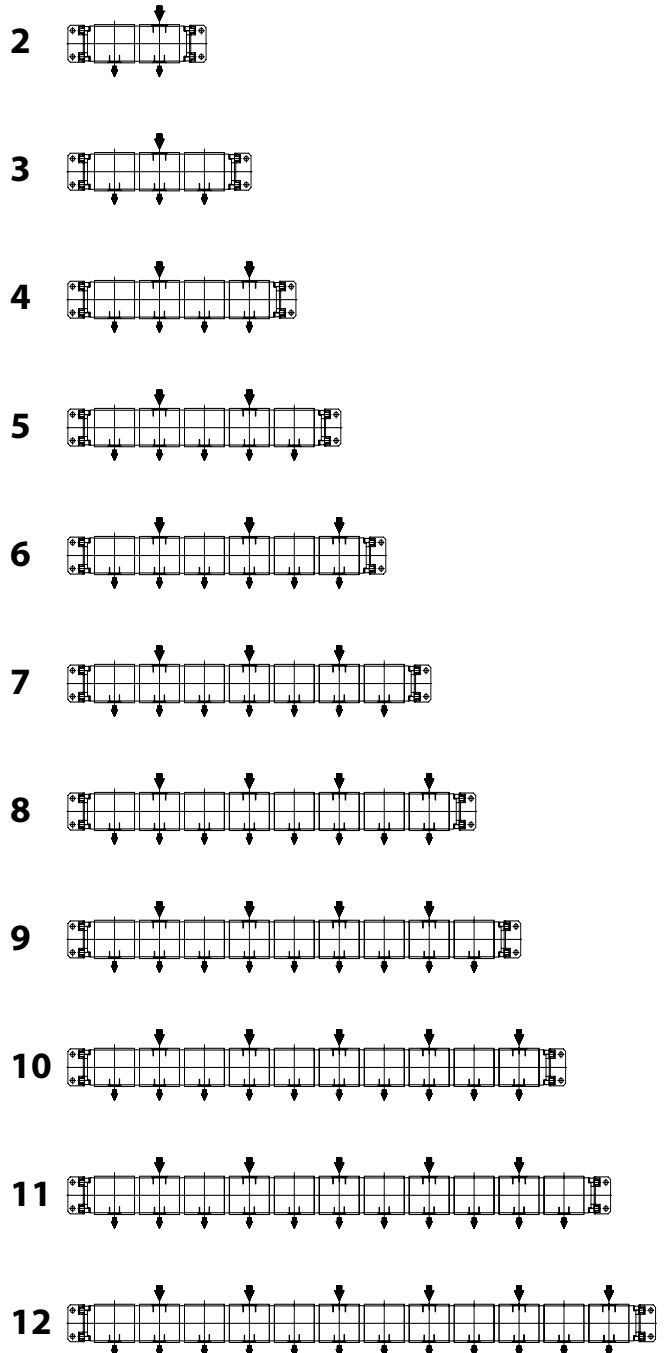

Integral pressure valves in the MTO

General points

Flow dividers must be fitted as close to the cylinders as possible and the pipe connections to the individual chambers must be of equal length, as far as this is possible.

Hydraulic fluids, viscosities

Oil flow dividers are designed for use of mineral oil in accordance with DIN 51524. The recommended oil viscosity is between 12 and 100 cSt, while at start-up they are approved for maximum values up to 600 cSt.

Temperature range

The operating temperature range is fixed at -25°C to +80°C with normal seals and at -25°C to +100°C when using Viton seals.

Filtration

Filtration is of critical importance especially to achieve high levels of synchronisation. Ultimately it is necessary to achieve the crucial metallic seal between the external surfaces of the gears and the internal bore of the housing. In any case over the past few years the subject of filtration has no longer been an issue, with the aim being not to accommodate a lower level of filtration, but to highlight the benefits of good filtration for the whole system. We recommend a nominal filter rating of 10 µm and an absolute value of 25 µm.

Oil or filter changes are to be carried out in accordance with the recommendations of the machine or oil manufacturer.

Installation instructions

In the case of valves for **piston flow divider** installation in the horizontal plane is the only essential requirement. Otherwise there are not special issues with regards to commissioning.

Gear flow dividers do not have a leakage oil connection and do not need to be filled with oil before commissioning.

Radial piston flow dividers in the **MT** range have two leakage oil connections that must both be connected. The leakage oil pressure must be a maximum of 1.5 bar. The leakage oil pipes must be fitted so that the housing cannot run dry. They must be unpressurised and return the oil to the tank.

In the **MTL** range of **radial piston flow dividers** there is a connection for leakage oil at both the beginning and the end. Only one of these needs to be connected, because the leakage oil chamber is connected to all

chambers of the divider. Leakage oil pressure maximum of 10 bar, or a maximum of 1.5 bar for versions with protruding measurement shaft.

Commissioning

The radial piston flow divider produces minimal leakage oil. As a result it is necessary to fill the housing with oil before commissioning; otherwise the period the flow divider runs dry will be much too long before it is lubricated by its own leakage oil. Regrettably this important point is seldom taken into account.

Low pressure feed and tank line

In the case of flow dividers with integral outlet blocks or integrated valves it is essential to ensure that the low pressure feed / tank line is connected correctly. Please check page 5 of the circuit diagram!

Divider-valves

The valve produces 2 flows or reunifies 2 flows. The total flow should lie between the minimum and maximum limits below. Within the flow-limits, the flow are nearly independent of oil-pressure and viscosity.

Using this valve it's important to know that a stop of the first flow causes a throttling of the second-one. This produces heat. Please take care of this fact.

Generally we recommend the alloy-version, last not least due to the lower costs. Only a pressure of over 210 bar leads to the steel-version.



| Type | Total flow minimal (l/min) | Total flow maximal (l/min) | Peak-pressure Type MKA (bar) | Peak-pressure Type MKS (bar) |
|------------------------|----------------------------|----------------------------|------------------------------|------------------------------|
| MKS-0 / 6 | 2 | 6 | - | 315 |
| MKA-1/12 MKS-1/12 | 4 | 12 | 210 | 350 |
| MKA-1/24 MKS-1/24 | 12 | 24 | 210 | 350 |
| MKA-1/40 MKS-1/40 | 24 | 40 | 210 | 350 |
| MKA-2/90 MKS-2/90 | 40 | 90 | 210 | 350 |
| MKA-2/150 MKS-2/150 | 90 | 150 | 210 | 350 |

Order-code

Example: **MKA-1/24**

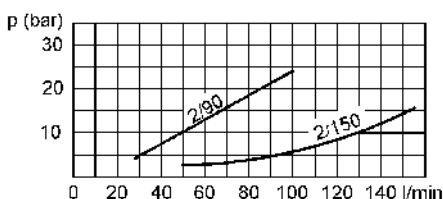
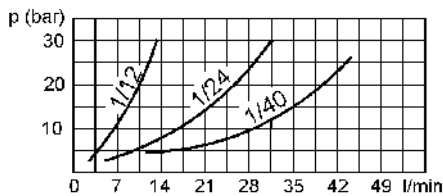
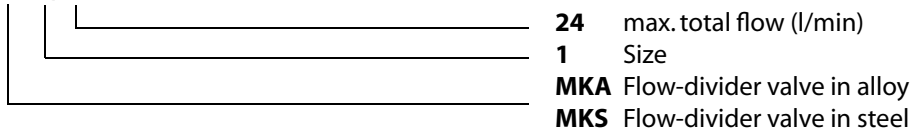

Internal pressure-drop in flow-divider-valves

Circuit according DIN ISO 1219

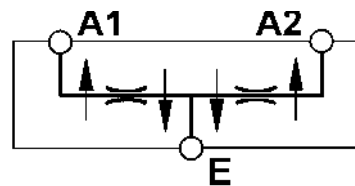

Divider-valves

Size 1

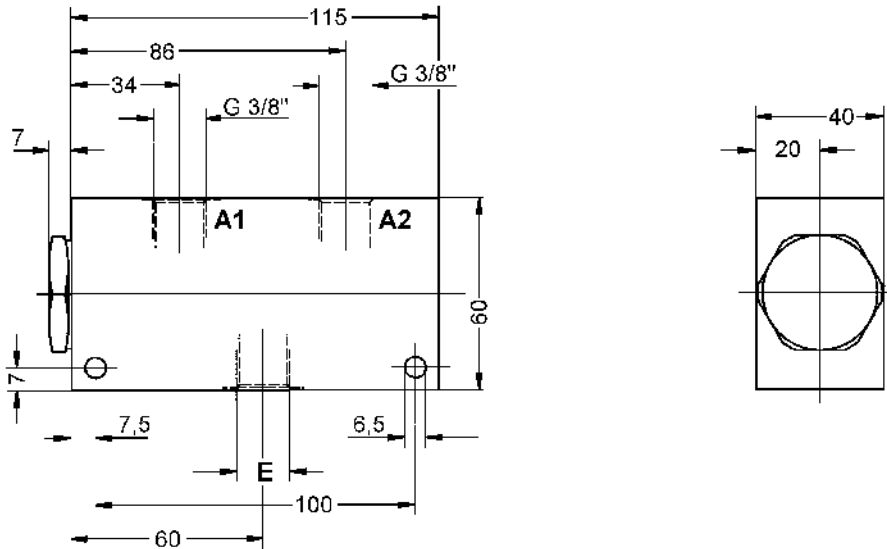

| Type | E | A | Weight MKA | Weight MKS |
|-----------------|-------|-------|------------|------------|
| MKA / MKS -1/12 | G3/8" | G3/8" | 0,80 kg | 1,85 kg |
| MKA / MKS-1/24 | G3/8" | G3/8" | 0,85 kg | 1,90 kg |
| MKA / MKS-1/40 | G1/2" | G3/8" | 0,85 kg | 1,90 kg |

Size 2

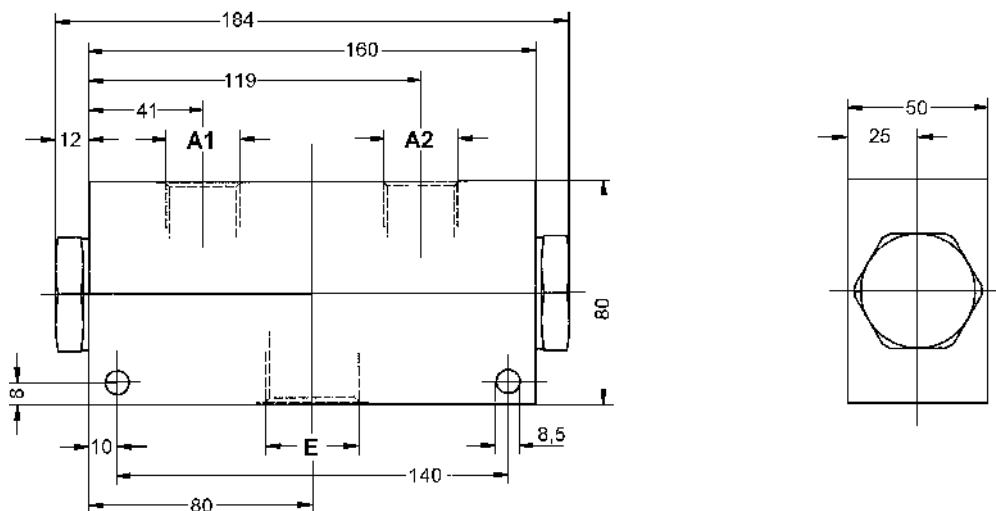

| Type | E | A | Weight MKA | Weight MKS |
|-----------------|-------|-------|------------|------------|
| MKA / MKS -2/90 | G3/4" | G1/2" | 2,1 kg | 4,4 kg |
| MKA / MKS-2/150 | G1" | G3/4" | 2,2 kg | 4,5 kg |

Gear flow-divider (aluminium housing) MTO Size 0

| Type | Displacement per section (cm ³ /U) | min. flow per section (l/min) | rec. flow per section (l/min) | max. flow per section (l/min) | Continue pressure (bar) | Peak pressure (bar) | max. pressure difference between the sections outputs (bar) |
|--------------------|---|-------------------------------|-------------------------------|-------------------------------|-------------------------|---------------------|---|
| Size 0 | | | | | | | |
| MTO-..-1 | 0,99 | 0,35 | 1,5 | 4 | 250 | 280 | 200 |
| Size 1 Page 14, 15 | | | | | | | |
| MTO-..-4 | 4,2 | 1,6 | 5,0 | 9 (10) | 250 | 280 | 200 |
| MTO-..-5 | 5,5 | 2,2 | 7,5 | 12 (14) | 230 | 250 | 200 |
| Size 2 Page 16, 17 | | | | | | | |
| MTO-..-8 | 8,16 | 3,5 | 12 | 19 (22) | 250 | 280 | 200 |
| MTO-..-14 | 14,45 | 5,0 | 20 | 32 (39) | 250 | 280 | 200 |
| MTO-..-31 | 31,4 | 12,5 | 35 | 62 (70) | 210 | 240 | 200 |

Providing that the flow-noise is not an issue, it is possible to increase the pressure values in the chambers.

Order codes

Example: **MTO-4-1-AVR**

4-section flow-divider with all section of 0,99 cm³/rev, pressure valve adjustable

| | |
|------------|---|
| AVR | Pressure control valves adjustable from 130 to 280 bar, standard Spring colour red , preset to approx. 180 bar |
| AVG | Pressure control valves adjustable from 90 to 200 bar, Spring colour green , preset to approx. 120 bar |
| AVB | Pressure control valves adjustable from 60 to 160 bar, Spring colour blue , preset to approx. 100 bar |
| AVS | Pressure control valves adjustable from 30 to 80 bar, Spring colour black , preset to approx. 50 bar |
| G | Divider without additional valves, threaded connector |
| 1 | Nominal displacement per chamber, actual displacement see above |
| 4 | Number of part flows, maximum 12 |

Gear flow-divider (aluminium housing) MTO Size 0

The drawing shows a 4-section flow-divider. Using more or less sections, you have to calculate the total length with a difference of **47,1 mm** each section.

MTO-...-G

Weight: MTO...-1-G 1,1 kg/section

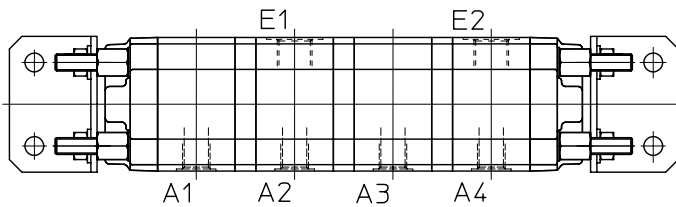
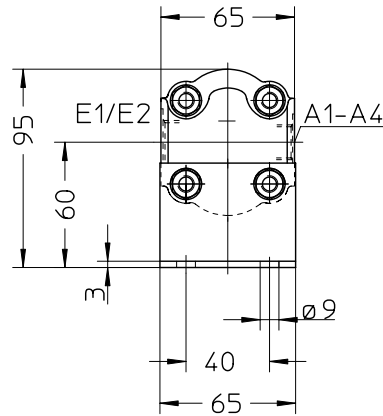
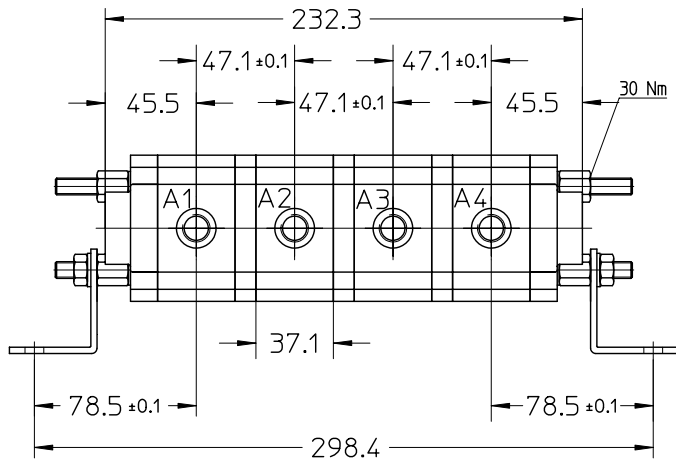

Connections

| | | |
|----------|--------------|-------------------------------|
| E1 to E2 | G3/8" | Input |
| A1 to A4 | G1/4" | Output, divided flows |
| T,NS | G3/8" | Tank and low-pressure-feeding |

MTO-...-A...

Weight: MTO...-1-A 1,6 kg/section

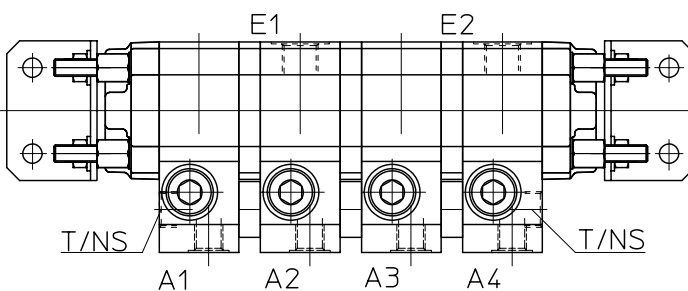
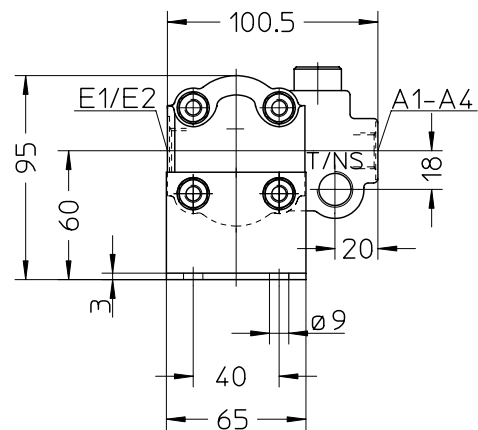
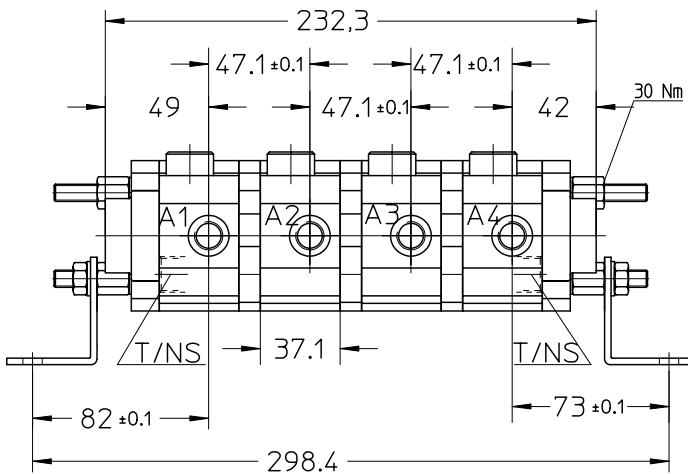

Circuit according DIN ISO 1219

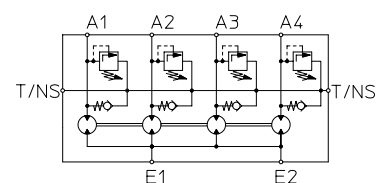

Gear flow-divider (aluminium housing) MTO Size 1

| Type | Displacement per section (cm ³ /rev) | min. flow per section (l/min) | max. flow per section (l/min) | Continue pressure (bar) | Peak pressure (bar) | max. pressure difference between the sections outputs (bar) |
|-------------------|---|-------------------------------|-------------------------------|-------------------------|---------------------|---|
| Size 1 | | | | | | |
| MTO-..-4 | 4,2 | 1,6 | 9 (10) | 250 | 280 | 200 |
| MTO-..-5 | 5,5 | 2,2 | 12 (14) | 230 | 250 | 200 |
| Size 2 Page16, 17 | | | | | | |
| MTO-..-8 | 8,16 | 3,5 | 19 (22) | 250 | 280 | 200 |
| MTO-..-14 | 14,45 | 5,0 | 32 (39) | 250 | 280 | 200 |
| MTO-..-31 | 31,4 | 12,5 | 62 (70) | 210 | 240 | 200 |

Providing that the flow-noise is not an issue, it is possible to increase the pressure values in the chambers.

Order codes

Example: **MTO-4-5-AVR**

4-section flow-divider with all section of 5,5 cm³/rev, pressure valve adjustable

| | |
|------------|---|
| AVR | Pressure control valves adjustable from 130 to 280 bar, standard Spring colour red , preset to approx. 180 bar |
| AVG | Pressure control valves adjustable from 90 to 200 bar, Spring colour green , preset to approx. 120 bar |
| AVB | Pressure control valves adjustable from 60 to 160 bar, Spring colour blue , preset to approx. 100 bar |
| AVS | Pressure control valves adjustable from 30 to 80 bar, Spring colour black , preset to approx. 50 bar |
| G | Divider without additional valves, threaded connector |
| 5 | Nominal displacement per chamber, actual displacement see above |
| 4 | Number of part flows, maximum 12 |

Gear flow-divider (aluminium housing) MTO Size 1

The drawing shows a 4-section flow-divider. Using more or less sections, you have to calculate the total length with a difference of **B** each section.

MTO-...-G

Weight: MTO...-4-G 1,1 kg/section
MTO...-5-G 1,2 kg/section

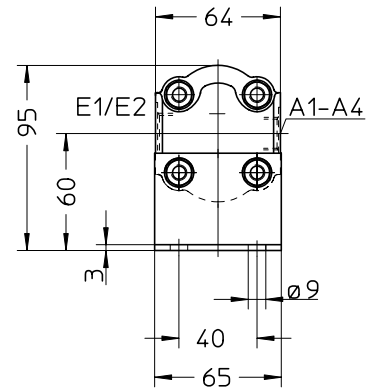
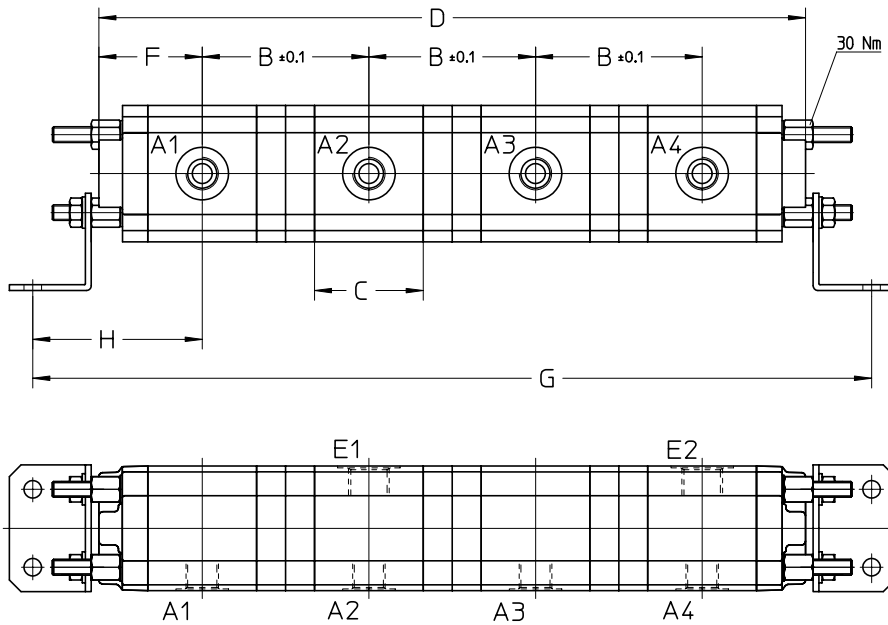

Connections

E1 to E2 **G1/2"** Input
A1 to A4 **G3/8"** Output, divided flows
T, NS **G3/8"** Tank and low-pressure-feeding

MTO-...-A...

Weight: MTO...-4-A 1,6 kg/section
MTO...-5-A 1,8 kg/section

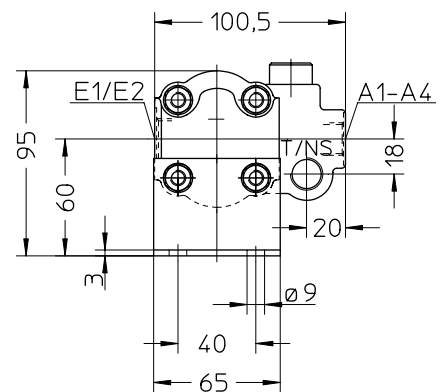
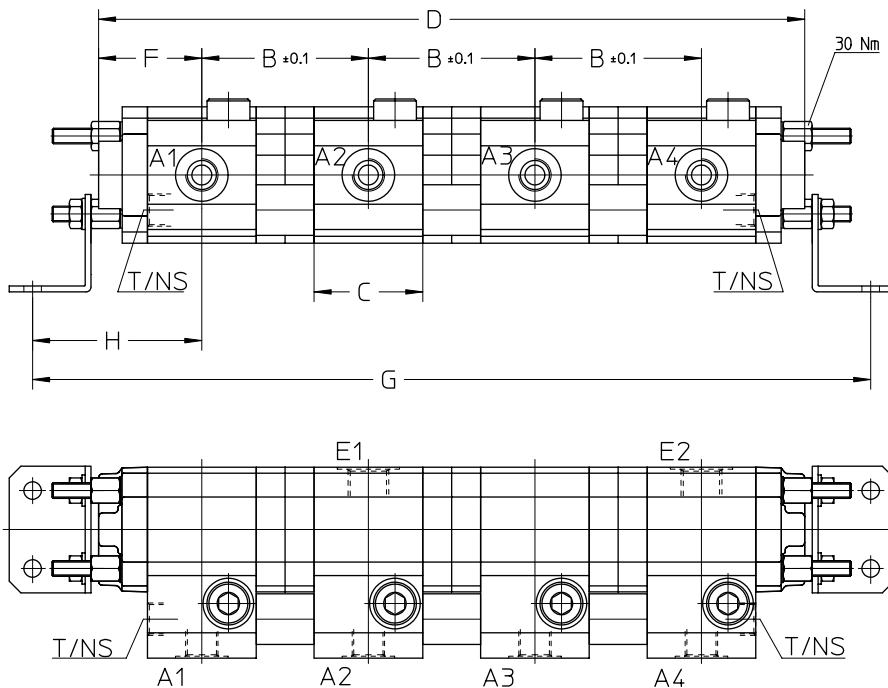

Circuit according DIN ISO 1219

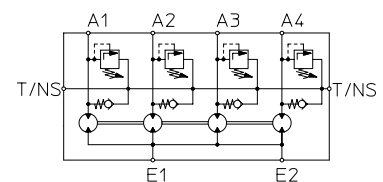

| Type | A1-4 | E1-2 | T/NS | B | C | D | F | G | H |
|----------|-------|-------|-------|------|------|-------|------|-------|------|
| MTO...-4 | G3/8" | G1/2" | G3/8" | 80,5 | 50,7 | 344,3 | 51,4 | 412,1 | 85,3 |
| MTO...-5 | | | | 85,7 | 55,9 | 364,9 | 53,9 | 432,7 | 87,8 |

Gear flow-divider (aluminium housing) MTO Size 2

| Type | Displacement per section (cm ³ /rev) | min. flow per section (l/min) | max. flow per section (l/min) | Continue pressure (bar) | Peak pressure (bar) | max. pressure difference between the sections outputs (bar) |
|--------------------|---|-------------------------------|-------------------------------|-------------------------|---------------------|---|
| Size 1 Page 12, 13 | | | | | | |
| MTO-..-4 | 4,2 | 1,6 | 9 (10) | 250 | 280 | 200 |
| MTO-..-5 | 5,5 | 2,2 | 12 (14) | 230 | 250 | 200 |
| Size 2 | | | | | | |
| MTO-..-8 | 8,16 | 3,5 | 19 (22) | 250 | 280 | 200 |
| MTO-..-14 | 14,45 | 5,0 | 32 (39) | 250 | 280 | 200 |
| MTO-..-31 | 31,4 | 12,5 | 62 (70) | 210 | 240 | 200 |

Providing that the flow-noise is not an issue, it is possible to increase the pressure values in the chambers.

Order codes

Example: **MTO-4-8-AVR**

4-section flow-divider with all section of 8,16 cm³/rev, pressure valve adjustable

| | |
|------------|---|
| AVR | Pressure control valves adjustable from 130 to 280 bar, standard Spring colour red , preset to approx. 180 bar |
| AVG | Pressure control valves adjustable from 90 to 200 bar, Spring colour green , preset to approx. 120 bar |
| AVB | Pressure control valves adjustable from 60 to 160 bar, Spring colour blue , preset to approx. 100 bar |
| AVS | Pressure control valves adjustable from 30 to 80 bar, Spring colour black , preset to approx. 50 bar |
| G | Divider without additional valves, threaded connector |
| 5 | Nominal displacement per chamber, actual displacement see above |
| 4 | Number of part flows, maximum 12 |

Gear flow-divider (aluminium housing) MTO Size 2

The drawing shows a 4-section flow-divider. Using more or less sections, you have to calculate the total length with a difference of **B** each section.

MTO-...-G

Weight: MTO-...-8-G 2,1 kg/section
 MTO-...-14-G 2,6 kg/section
 MTO-...-31-G 3,5 kg/section

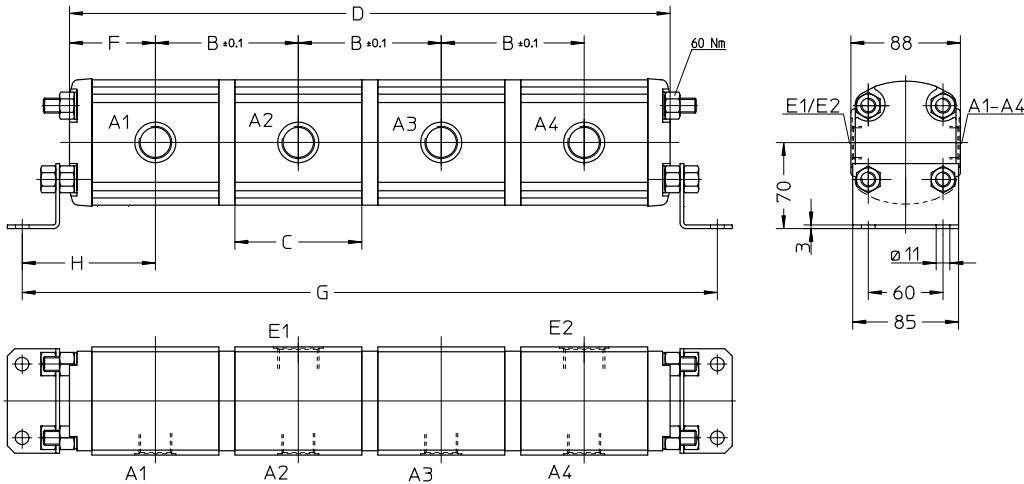

Connections

E1 to E2 Input
 A1 to A4 Output, divided flow
 T, NS Tank and low-pressure-feeding

MTO-...-A..

Weight: MTO-...-8-A 2,7 kg/section
 MTO-...-14-A 3,4 kg/section
 MTO-...-31-A 4,5 kg/section

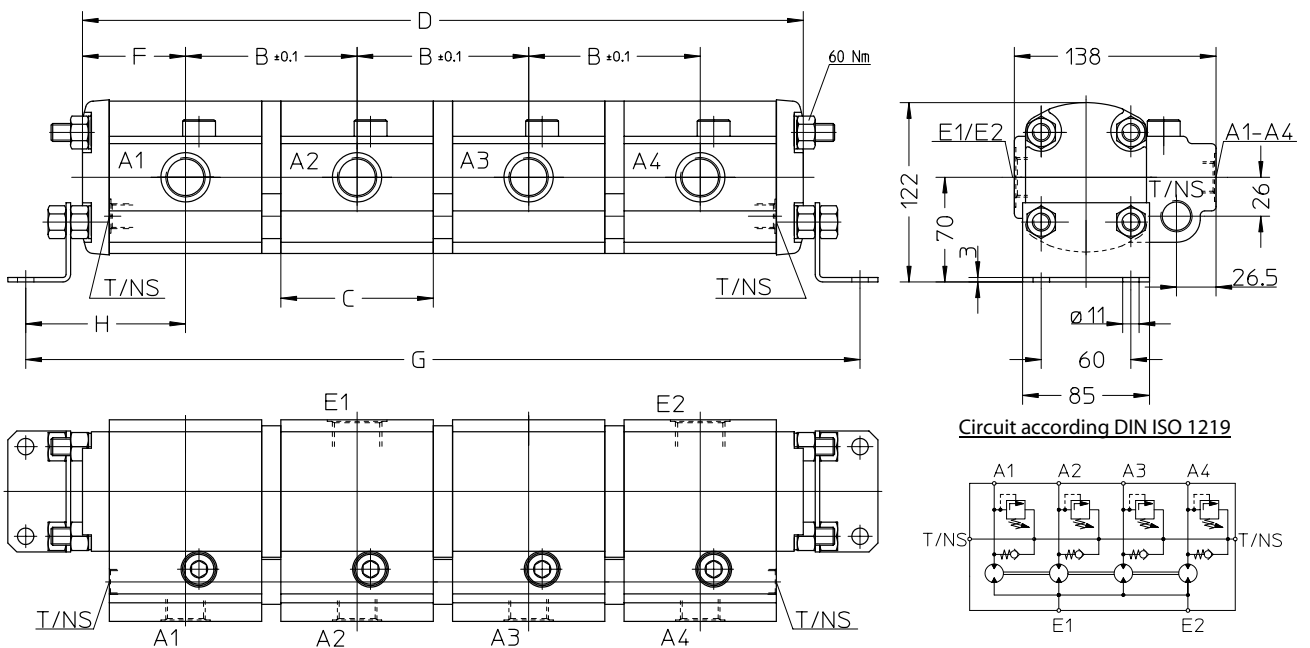

| Type | A1-4 | E1-2 | T/NS | B | C | D | F | G | H |
|------------|-------|-------|-------|-----|-------|-----|------|-------|-------|
| MTO-...-8 | G1/2" | G3/4" | G1/2" | 70 | 57,1 | 303 | 46,5 | 379,2 | 84,6 |
| MTO-...-14 | G1/2" | G3/4" | | 88 | 75,1 | 375 | 55,5 | 451,2 | 93,6 |
| MTO-...-31 | G3/4" | G1" | | 115 | 102,1 | 483 | 69,0 | 559,2 | 107,1 |

MTO Gear flow-divider (cast iron housing) Size 3

| Type | Displacement per section (cm ³ /U) | min. flow per section (l/min) | max. flow per section (l/min) | Continue pressure (bar) | Peak pressure (bar) |
|--------------------|---|-------------------------------|-------------------------------|-------------------------|---------------------|
| Size 3 | | | | | |
| MTO-.-25 | 24,9 | 12 | 66 | 270 | 290 |
| MTO-.-35 | 34,3 | 16 | 82 | 260 | 285 |
| MTO-.-55 | 54,5 | 27 | 98 | 260 | 285 |
| MTO-.-80 | 78,7 | 40 | 140 | 260 | 285 |
| Size 4 Page 22, 23 | | | | | |
| MTO-.-110 | 105,4 | 50 | 200 | 270 | 290 |
| MTO-.-150 | 149,7 | 80 | 220 | 235 | 250 |

Order codes

Example: **MTO-4-55-EA7**

4-section flow-divider with all sections of 54,5 cm³/rev.

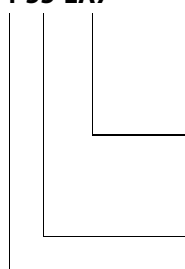

- G** Threated connection
- GB** Threated connection, for valve block assembly
- E** Inlet block
- A7** Outlet block, design series 7
- Displacement per section
- Number of section, maximum 8

Restrictions in the use of other operating fluids than mineral oil

| Type | Fluid | max. pressure (bar) | max. revs (rev/min) | temperatur range | seals |
|--|-----------------|---------------------|---------------------|------------------|-------|
| HFC | water glycol | 160 | 1300 | -20 bis 60°C | * |
| HFD | phosphate ester | 160 | 1500 | -10 bis 60°C | FKM |
| * Perbunan oder FKM according to the HFC manufacturer's recommendation | | | | | |

MTO Gear flow-divider (cast iron housing) Size 3 EA7

The drawing shows a 4-section flow-divider. Using more or less sections, you have to calculate the total length with a difference of 167,5 mm each section.

MTO-...-G

Weight: 17 kg/section

Connections

E **G1"** Input
A1 to A4 **G1"** Output, divided flows

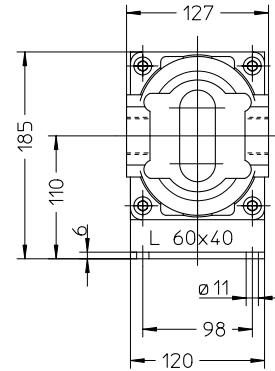
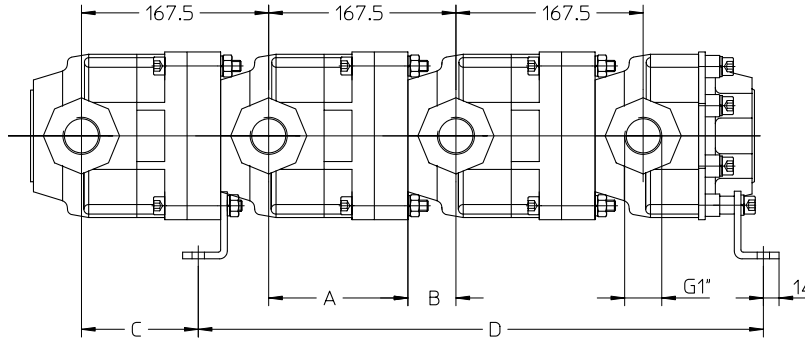

Connections

E **G1 1/4"** Input
A1 to A4 **G1 1/4"** Output, divided flows
T, NS **G1/2"** Tank and low-pressure-feeding
M1 to M4 **G3/4"** Measuring port for each section

MTO-...-EA7

Weight: 22 kg/section

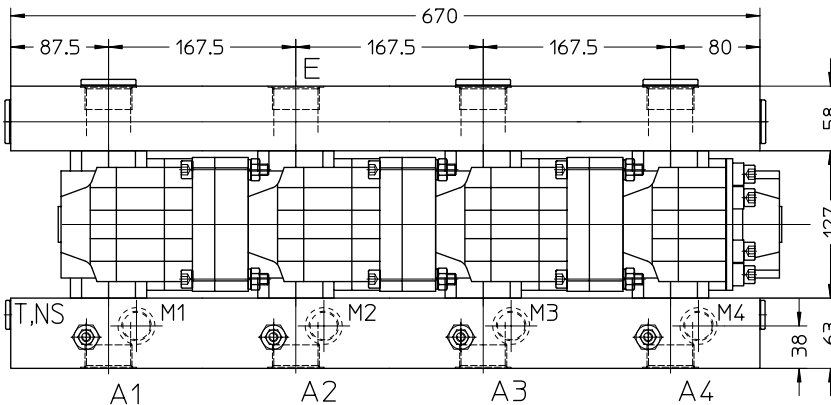
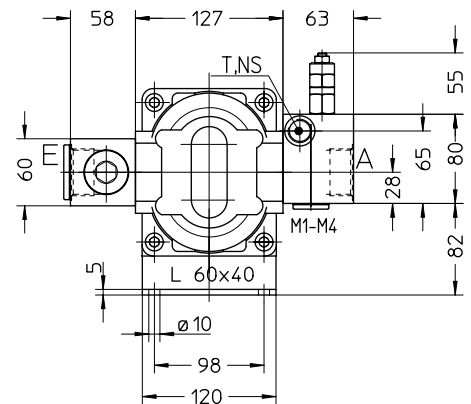
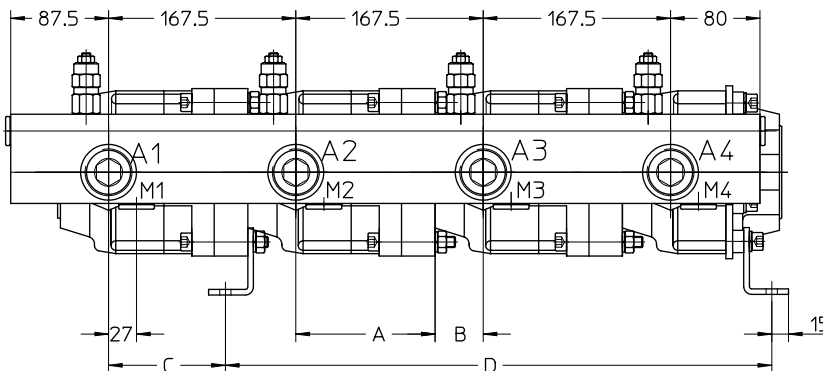

Circuit according DIN ISO 1219

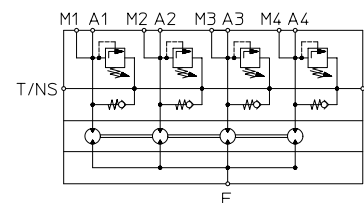

| Type | A | B | C | D |
|-------------------|-------|------|-------|-------|
| MTO-...-35 | 130,0 | 37,5 | 110,0 | 471,5 |
| MTO-...-55 | 124,5 | 43,0 | 104,5 | 488,5 |
| MTO-...-80 | 109,0 | 58,5 | 89,0 | 504,0 |

Gear flow-divider (cast iron housing) MTO Size 3

| Type | Displacement per section (cm ³ /U) | min. flow per section (l/min) | max. flow per section (l/min) | Continue pressure (bar) | Peak pressure (bar) |
|--------------------|---|-------------------------------|-------------------------------|-------------------------|---------------------|
| Size 3 | | | | | |
| MTO-..-25 | 24,9 | 12 | 66 | 270 | 290 |
| MTO-..-35 | 34,3 | 16 | 82 | 260 | 285 |
| MTO-..-55 | 54,5 | 27 | 98 | 260 | 285 |
| MTO-..-80 | 78,7 | 40 | 140 | 260 | 285 |
| Size 4 Page 22, 23 | | | | | |
| MTO-..-110 | 105,4 | 50 | 200 | 270 | 290 |
| MTO-..-150 | 149,7 | 80 | 220 | 235 | 250 |

Order codes

Example: **MTO-4-55-EA9**

4-section flow-divider with all sections of 54,5 cm³/rev.

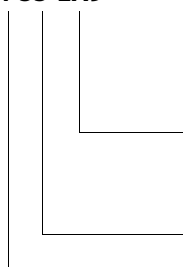

- G** Threated connection
- GB** Threated connection, for valve block assembly
- E** Inlet block
- A9** Outlet block, design series 9
- Displacement per section
- Number of section, maximum 8

Restrictions in the use of other operating fluids than mineral oil

| Type | Fluid | max. pressure (bar) | max. revs (rev/min) | temperatur range | seals |
|------------|-----------------|---------------------|---------------------|------------------|-------|
| HFC | water glycol | 160 | 1300 | -20 bis 60°C | * |
| HFD | phosphate ester | 160 | 1500 | -10 bis 60°C | FKM |

* Perbunan oder FKM according to the HFC manufacturer's recommendation

Gear flow-divider (cast iron housing) MTO Size 3 EA9

The drawing shows a 4-section flow-divider. Using more or less sections, you have to calculate the total length with a difference of 167,5 mm each section.

MTO-...-G

Weight: 17 kg/section

Connections

E **G1"** Input
 A1 to A4 **G1"** Output, divided flows

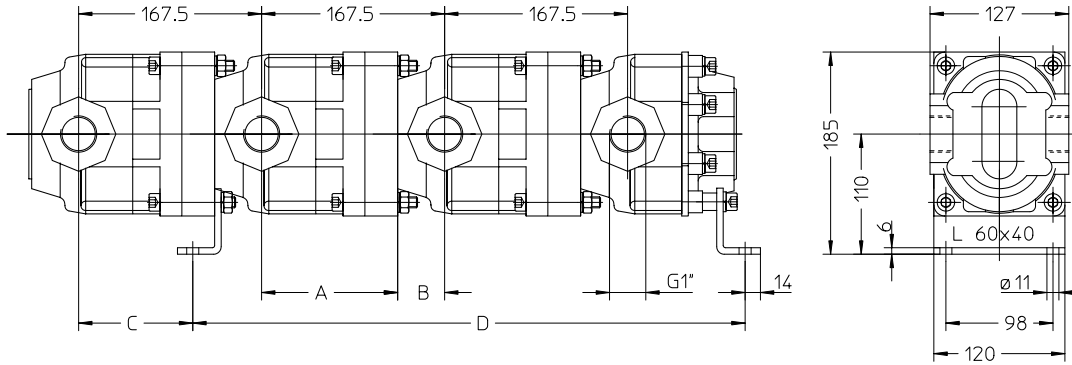

Connections

E **G1 1/4"** Input
 A1 to A4 **G1 1/4"** Output, divided flows
 T, NS **G1 1/4"** Tank and low-pressure-feeding
 M1 to M4 **G1/4"** Measuring port for each section

MTO-...-EA9

Weight: 36 kg/section

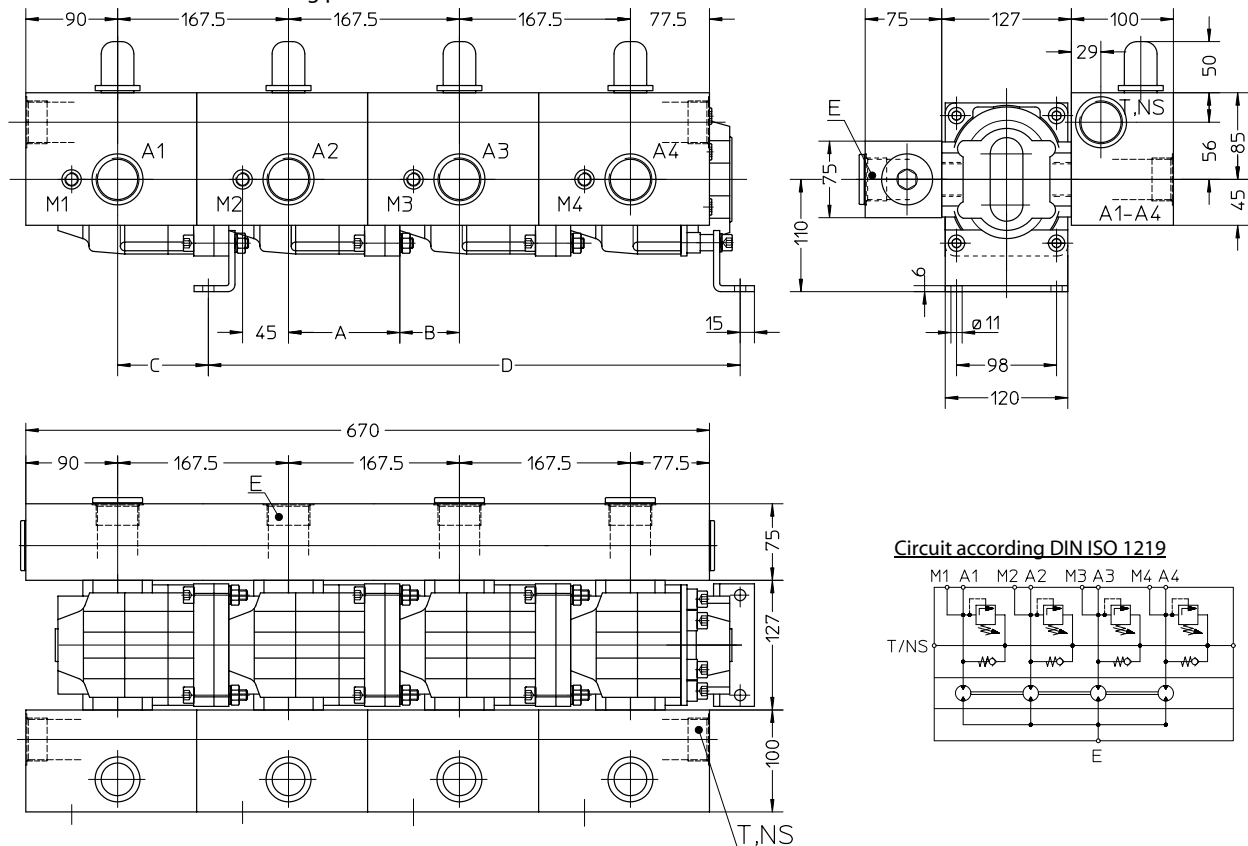

| Type | A | B | C | D |
|-------------------|-------|------|-------|-------|
| MTO-...-35 | 126,0 | 41,5 | 104,5 | 492,5 |
| MTO-...-55 | 124,5 | 43,0 | 104,5 | 505,5 |
| MTO-...-80 | 109,0 | 58,5 | 89,0 | 521,0 |

MTO Gear flow-divider (cast iron housing) Size 4

| Type | Displacement per section (cm ³ /U) | min. flow per section (l/min) | max. flow per section (l/min) | Continue pressure (bar) | Peak pressure (bar) |
|-------------------|---|-------------------------------|-------------------------------|-------------------------|---------------------|
| Size 3 Page 18,21 | | | | | |
| MTO-..-25 | 24,9 | 12 | 66 | 270 | 290 |
| MTO-..-35 | 34,3 | 16 | 82 | 260 | 285 |
| MTO-..-55 | 54,5 | 27 | 98 | 260 | 285 |
| MTO-..-80 | 78,7 | 40 | 140 | 260 | 285 |
| Size 4 | | | | | |
| MTO-..-110 | 105,4 | 50 | 200 | 270 | 290 |
| MTO-..-150 | 149,7 | 80 | 220 | 235 | 250 |

Order codes

Example: **MTO-4-110-EA9**

4-section flow-divider with all sections of 105,4 cm³/rev.

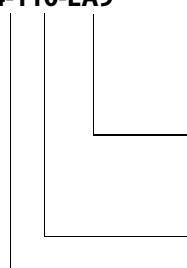

- S** SAE 1 1/2" 3000 psi
 - SB** SAE 1 1/2" 3000 psi, for valve block assembly
 - E** Inlet block
 - A9** Outlet block, design series 9
- Displacement per section
Number of section, maximum 8

Restrictions in the use of other operating fluids than mineral oil

| Type | Fluid | max. pressure (bar) | max. revs (rev/min) | temperatur range | seals |
|------------|-----------------|---------------------|---------------------|------------------|-------|
| HFC | water glycol | 160 | 1300 | -20 bis 60°C | * |
| HFD | phosphate ester | 160 | 1500 | -10 bis 60°C | FKM |

* Perbunan oder FKM according to the HFC manufacturer's recommendation

MTO Gear flow-divider (cast iron housing) Size 4

The drawing shows a 4-section flow-divider. Using more or less sections, you have to calculate the total length with a difference of **B** each section.

MTO-...-S

Weight: 25 kg/section

Connections

E1 to E4 **SAE 1 1/2" 3000 psi**, Input
 A1 to A4 **SAE 1 1/2" 3000 psi**, Output, divided flows

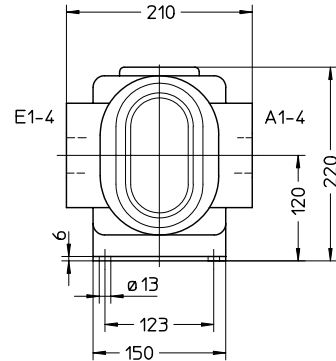
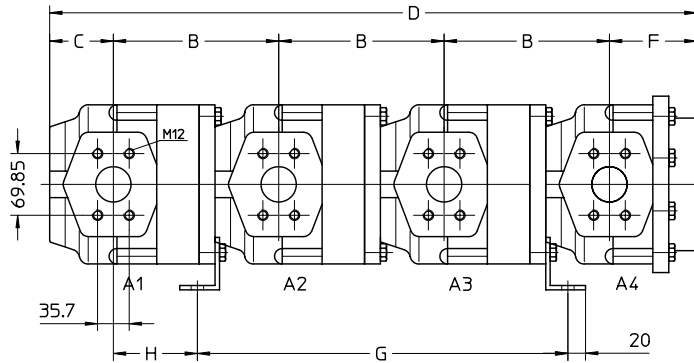

Connections

E1 to E2 **SAE 2" 6000 psi**, Input
 A1 to A4 **SAE 1 1/2" 6000 psi**, Output, divided flows
 T, NS **G1 1/4"** Tank and low-pressure-feeding
 M1 to M4 **G1/4"** Measuring port for each section

MTO-...-EA9

Weight: 56 kg/section

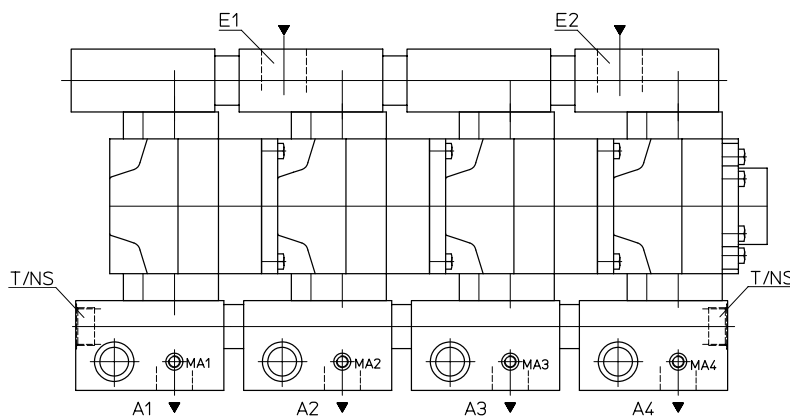
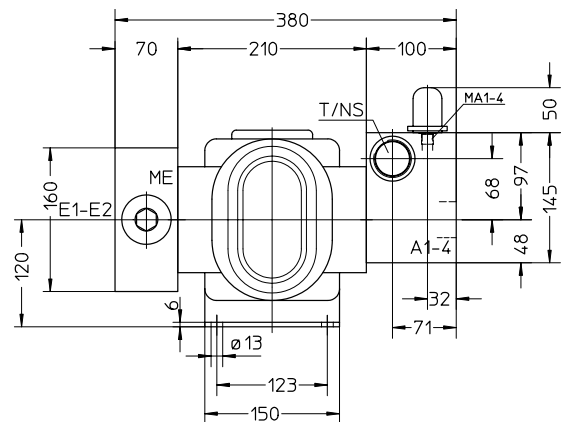
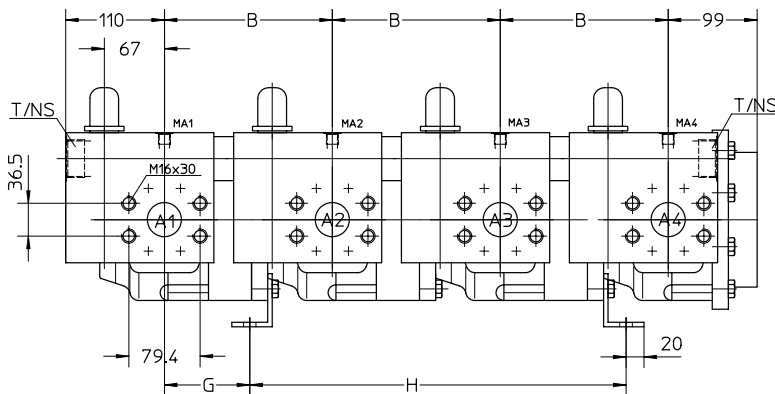

Circuit according DIN ISO 1219

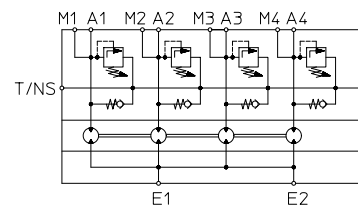

| Typ | B | C | D | F | G | H |
|--------------------|-----|-----|-------|-------|----|-----|
| MTO-...-110 | 171 | 117 | 683,5 | 99,5 | 92 | 419 |
| MTO-...-150 | 187 | 133 | 747,5 | 102,5 | 95 | 387 |

HTO Gear flow-divider (cast iron housing) Size 3

| Type | Displacement per section (cm ³ /U) | min. flow per section (l/min) | max. flow per section (l/min) | Continue pressure (bar) | Peak pressure (bar) |
|-------------------|---|-------------------------------|-------------------------------|-------------------------|---------------------|
| Size 3 | | | | | |
| HTO-..-35 | 34,3 | 12 | 82 | 320 | 380 |
| HTO-..-80 | 78,7 | 27 | 140 | 320 | 380 |
| Size 4 Page 26,27 | | | | | |
| HTO-..-110 | 105,4 | 50 | 200 | 320 | 380 |
| HTO-..-150 | 149,7 | 80 | 220 | 320 | 380 |

Order codes

Example: **HTO-4-35-FI**

4-section flow-divider with all sections of 34,3 cm³/rev.

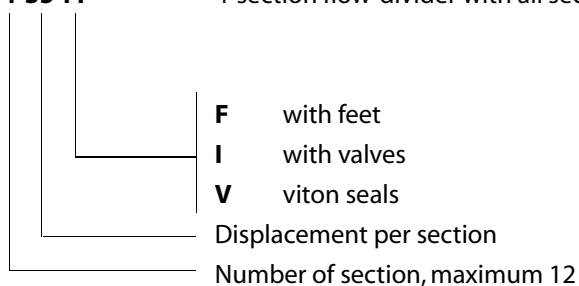

Restrictions in the use of other operating fluids than mineral oil

| Type | Fluid | max. pressure (bar) | max. revs (rev/min) | temperatur range | seals |
|--|-----------------|---------------------|---------------------|------------------|-------|
| HFC | water glycol | 160 | 1300 | -20 bis 60°C | * |
| HFD | phosphate ester | 160 | 1500 | -10 bis 60°C | FKM |
| * Perbunan oder FKM according to the HFC manufacturer's recommendation | | | | | |

HTO Gear flow-divider (cast iron housing) Size 3

The drawing shows a 4-section flow-divider. Using more or less sections, you have to calculate the total length with a difference of 167,5 mm each section.

HTO-...-FI

Weight: 40 kg/section

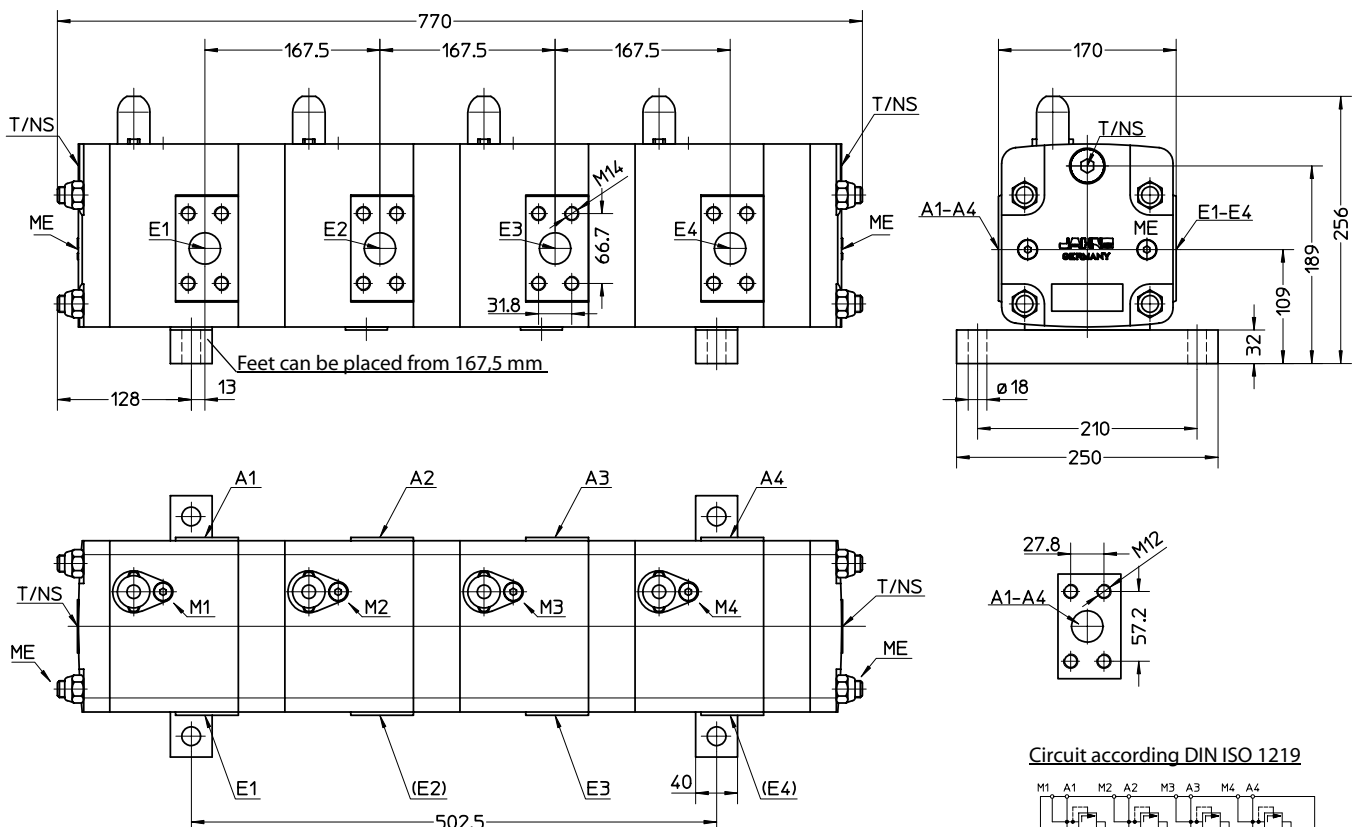

Connections

| | |
|----------|--|
| E1 to E4 | SAE NW32 420 bar (1 1/4", 6000 psi) , Input |
| A1 to A4 | SAE NW25 420 bar (1", 6000 psi) , Output, divided flows |
| T, NS | G3/4" Tank and low-pressure-feeding |
| ME | G1/4" Measuring, input |
| M1 to M4 | G1/4" Measuring port for each section, output |

HTO Gear flow-divider (cast iron housing) Size 4

| Type | Displacement per section (cm ³ /U) | min. flow per section (l/min) | max. flow per section (l/min) | Continue pressure (bar) | Peak pressure (bar) |
|--------------------|---|-------------------------------|-------------------------------|-------------------------|---------------------|
| Size 3 Page 24, 25 | | | | | |
| HTO-..-35 | 34,3 | 16 | 82 | 320 | 380 |
| HTO-..-80 | 78,7 | 40 | 140 | 320 | 380 |
| Size 4 | | | | | |
| HTO-..-110 | 105,4 | 50 | 200 | 320 | 380 |
| HTO-..-150 | 149,7 | 80 | 220 | 320 | 380 |

Order codes

Example: **HTO-4-110-FI**

4-section flow-divider with all sections of 105,4 cm³/rev.

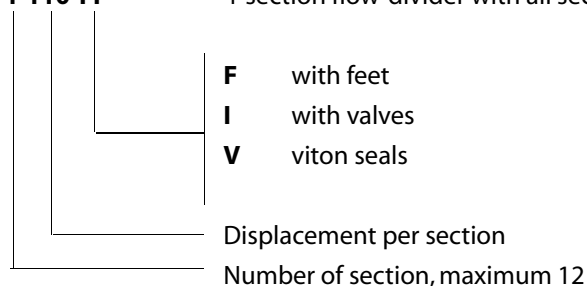

Restrictions in the use of other operating fluids than mineral oil

| Type | Fluid | max. pressure (bar) | max. revs (rev/min) | temperatur range | seals |
|------------|-----------------|---------------------|---------------------|------------------|-------|
| HFC | water glycol | 160 | 1300 | -20 bis 60°C | * |
| HFD | phosphate ester | 160 | 1500 | -10 bis 60°C | FKM |

* Perbunan oder FKM according to the HFC manufacturer's recommendation

HTO Gear flow-divider (cast iron housing) Size 4

The drawing shows a 4-section flow-divider. Using more or less sections, you have to calculate the total length with a difference of **194 mm** each section.

HTO-...-FI

Weight: 75 kg/section

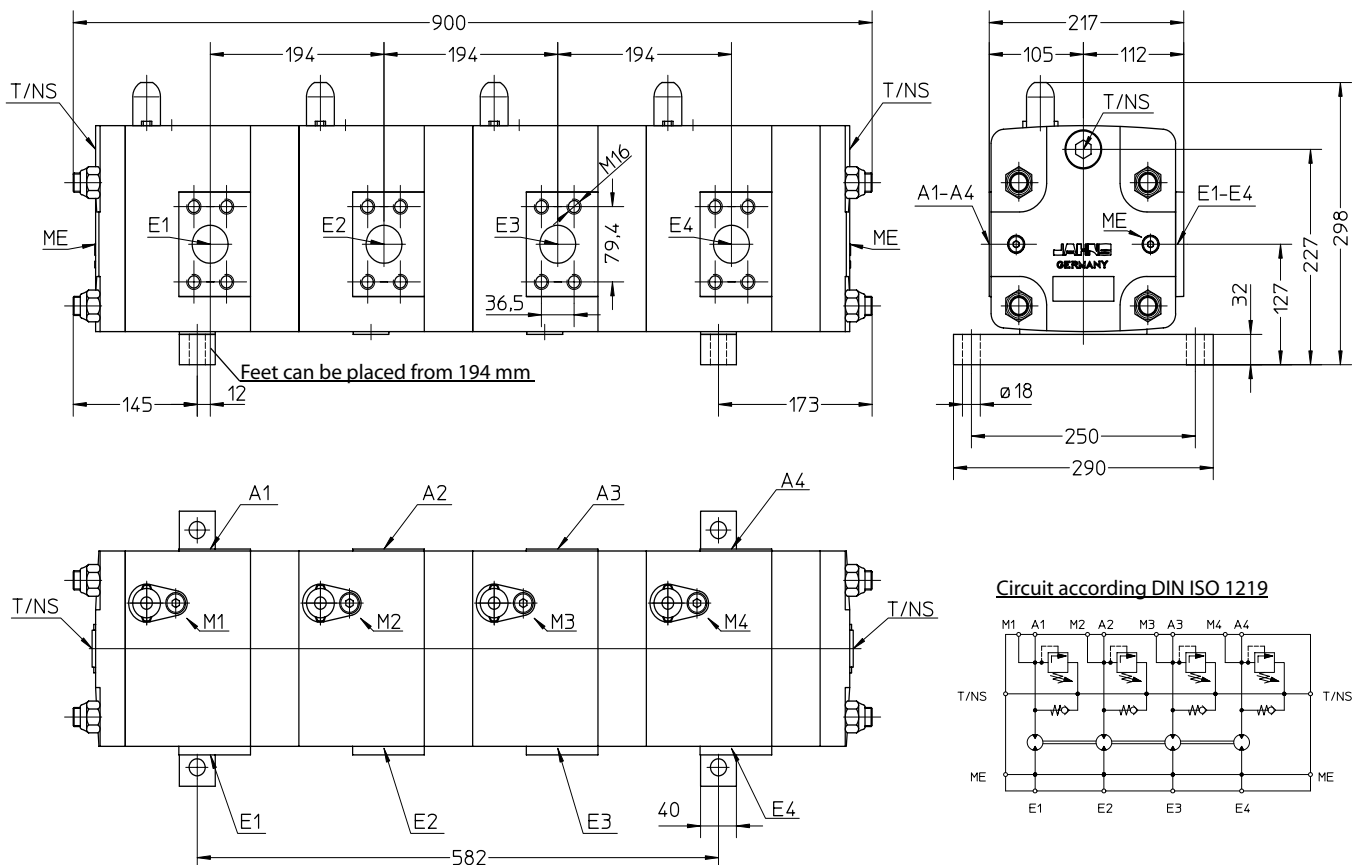

Connections

| | |
|----------|---|
| E1 to E2 | SAE NW40 420 bar (1 1/2", 6000 psi), Input |
| A1 to A4 | SAE NW40 420 bar (1 1/2", 6000 psi), Output, divided flows |
| T, NS | G1" Tank and low-pressure-feeding |
| ME | G1/4" Measuring, input |
| M1 to M4 | G1/4" Measuring port for each section, output |

Radial piston flow divider MT-GM

| Type | | Displacement per section cm ³ /rev | Flow per section | | Pressure | | Max power per section kW |
|---------------|------------------|---|------------------|---------|------------|--------------|--------------------------------|
| | | | continuous | maximum | continuous | intermittend | |
| | | | l/min | l/min | bar | bar | |
| MT-GM1 | 100/100 | 99 | 35 | 50 | 240 | 300 | 24 |
| MT-GM1 | 175/175 | 172 | 70 | 100 | 240 | 300 | 30 |
| MT-GM2 | 350/350 | 347 | 120 | 175 | 240 | 300 | 45 |
| MT-GM2 | 500/500 | 493 | 145 | 210 | 240 | 300 | 45 |
| MT-GM3 | 800/800 | 792 | 235 | 280 | 240 | 300 | 60 |
| MT-GM5 | 1800/1800 | 1816 | 340 | 430 | 240 | 300 | 90 |
| MT-GM6 | 3000/3000 | 3041 | 430 | 550 | 240 | 300 | 120 |

Complete drawings of the assembled units of different sizes to be used as pressure-multipliers or flow-dividers are available upon request.

Order Codes Example: **MT-GM1-100/100-FG**

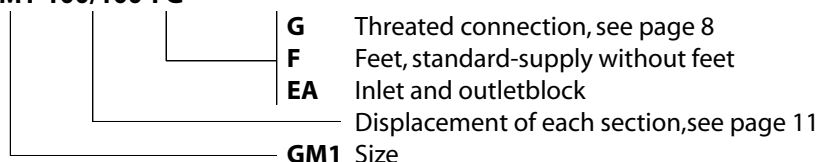

MT-GM1... / ...-FG

Weight: 70 kg

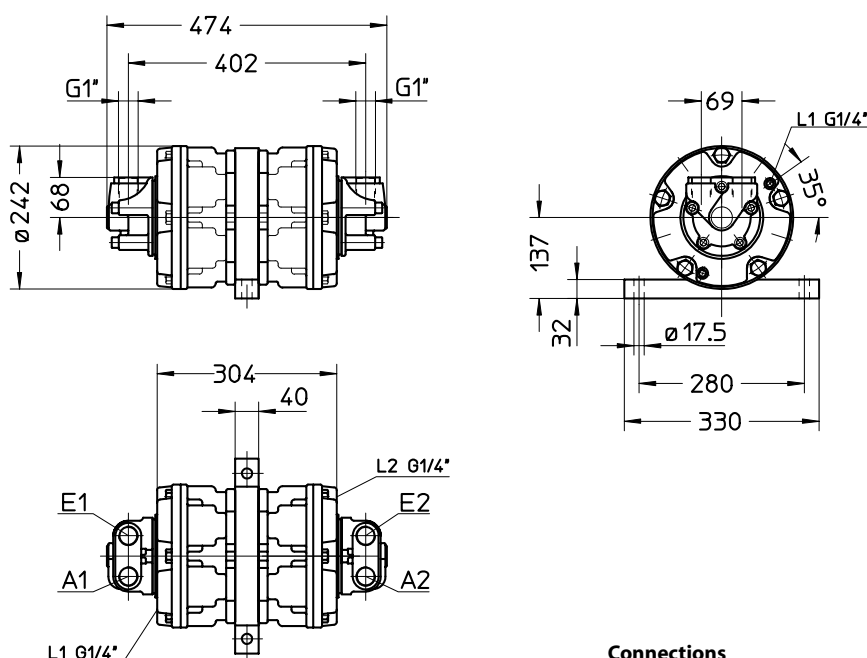

Connections

- E1 - E2 **G1"** Input, to be connected together
 - A1 - A2 **G1"** Output, section-flows
 - L1 - L2 **G1/4"** Drain-ports, drain pressure max. 2 bar
- Important:** both ports have to be connected to the tank !

Radial piston flow divider MT-GM

MT-GM2... / ...-FG

Weight: 130 kg

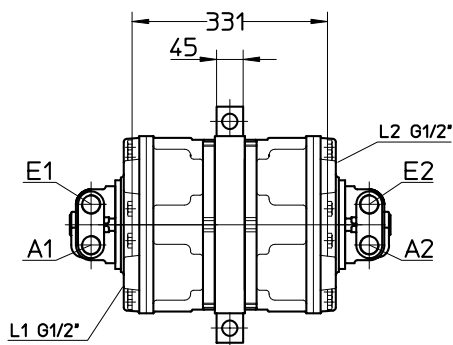
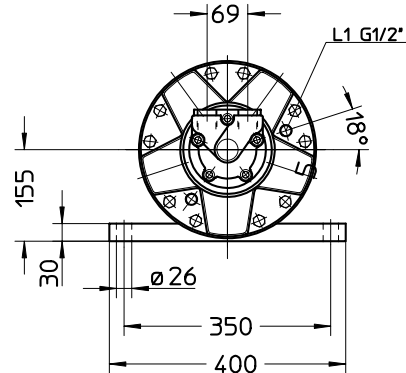
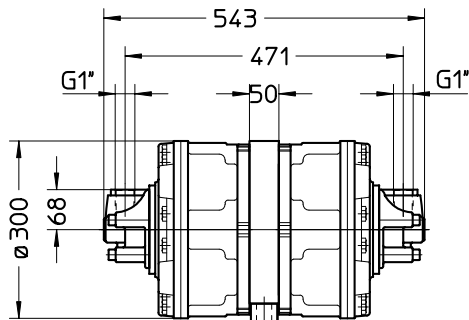

Connections

- E1 - E2 **G1"** Input, to be connected together
- A1 - A2 **G1"** Output, section-flows
- L1 - L2 **G1/2"** Drain-ports, drain pressure max. 2 bar

Important: both ports have to be connected to the tank !

MT-GM3... / ...-FG

Weight: 215 kg

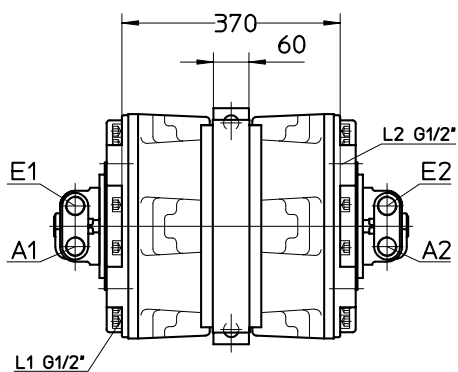
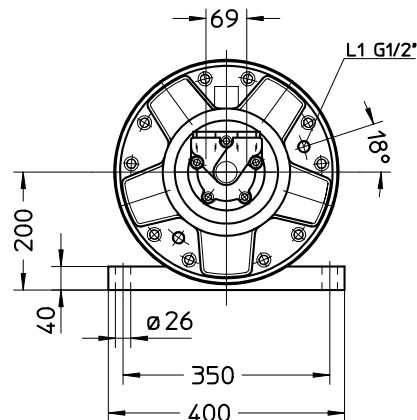
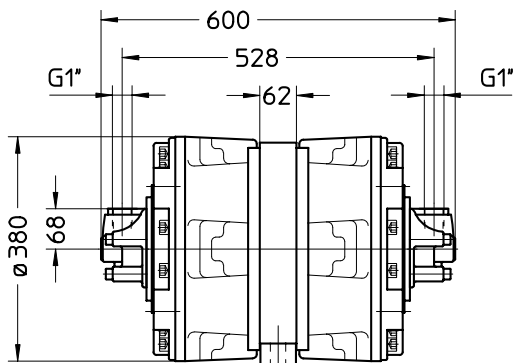

Connections

- E1 - E2 **G1"** Input, to be connected together
- A1 - A2 **G1"** Output, section-flows
- L1 - L2 **G1/2"** Drain-ports, drain pressure max. 2 bar

Important: both ports have to be connected to the tank !

Radial piston flow divider MT-GM

MT-GM5... / ...-FS

Weight: 425 kg

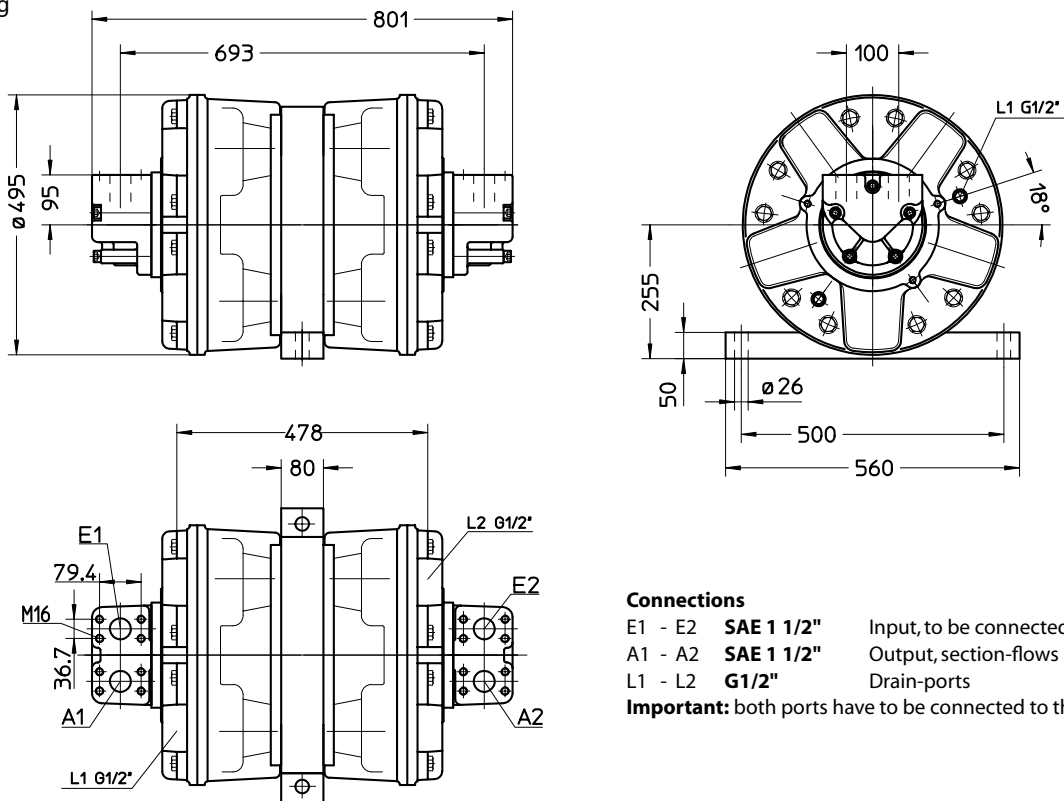

Connections

- E1 - E2 **SAE 1 1/2"** Input, to be connected together
- A1 - A2 **SAE 1 1/2"** Output, section-flows
- L1 - L2 **G1/2"** Drain-ports

Important: both ports have to be connected to the tank !

MT-GM6... / ...-FS

Weight: 550 kg

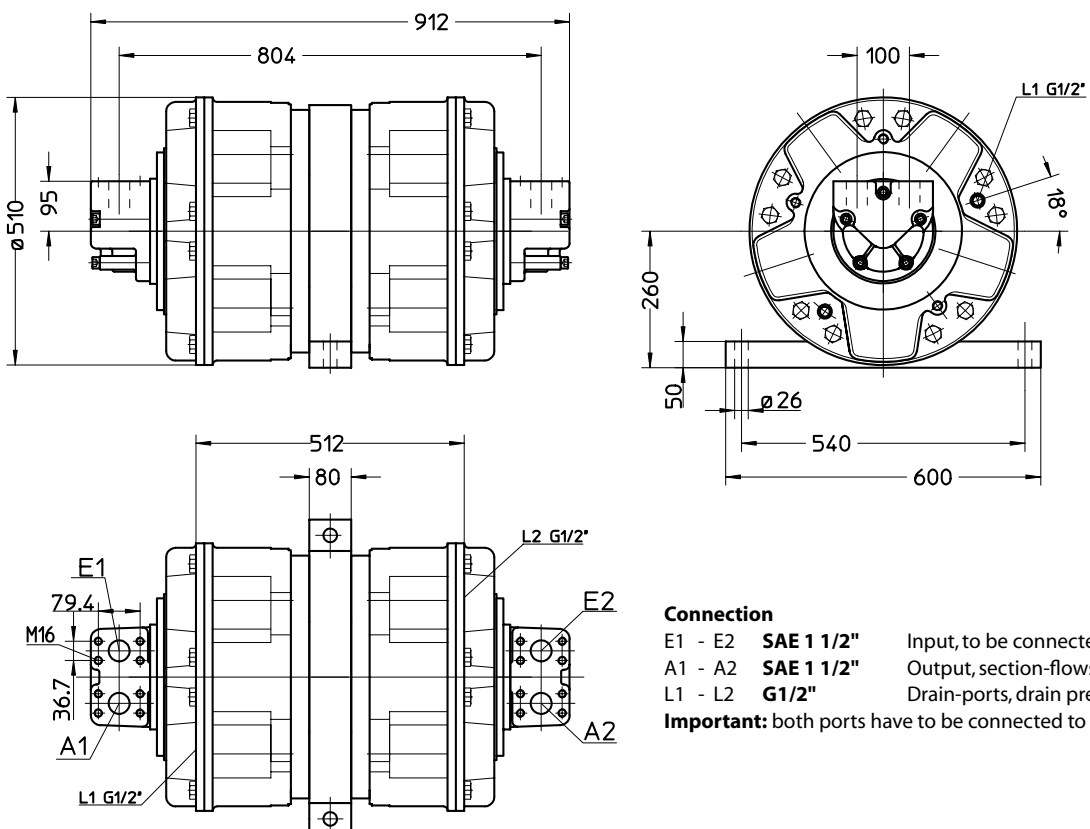

Connection

- E1 - E2 **SAE 1 1/2"** Input, to be connected together
- A1 - A2 **SAE 1 1/2"** Output, section-flows
- L1 - L2 **G1/2"** Drain-ports, drain pressure max. 2 bar

Important: both ports have to be connected to the tank !

Radial piston flow divider MT-GM

| Typ | Displacement per section | Flow per section | | Betriebsdruck | | Max power per section |
|-------------------------|-----------------------------|------------------|---------|---------------|--------------|--------------------------|
| | | continuous | maximum | continuous | intermittend | |
| | cm ³ /rev. | l/min | l/min | bar | bar | kW |
| MT-GM1 100/100 | 99 | 35 | 50 | 240 | 300 | 24 |
| MT-GM1 175/175 | 172 | 70 | 100 | 240 | 300 | 30 |
| MT-GM2 350/350 | 347 | 120 | 175 | 240 | 300 | 45 |
| MT-GM2 500/500 | 493 | 145 | 210 | 240 | 300 | 45 |
| MT-GM3 800/800 | 792 | 235 | 280 | 240 | 300 | 60 |
| MT-GM5 1800/1800 | 1816 | 340 | 430 | 240 | 300 | 90 |
| MT-GM6 3000/3000 | 3041 | 430 | 550 | 240 | 300 | 120 |

Complete drawings of the assembled units of different sizes to be used as pressure-multipliers or flow-dividers are available upon request.

Order Codes Example: MT-GM1-100/100-FEA

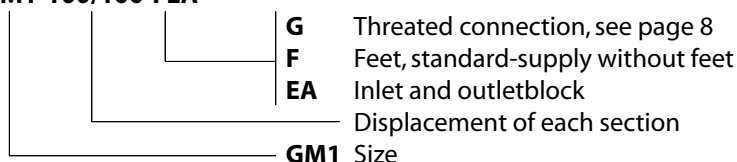

MT-GM1... / ...-FEA

Weight: 90 kg

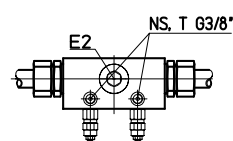
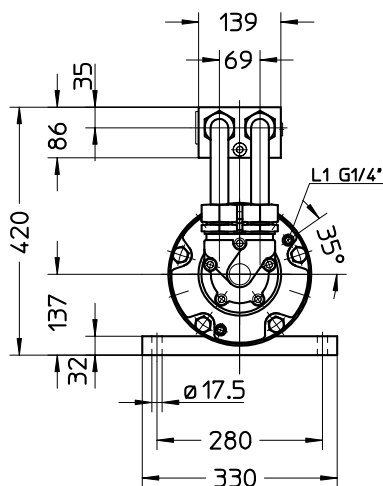
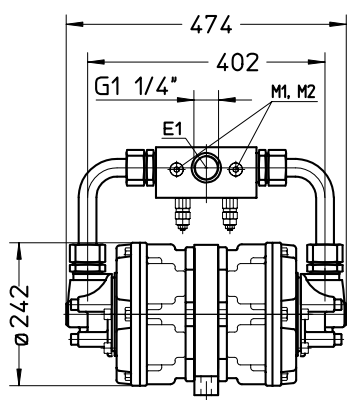

Circuit according DIN ISO 1219

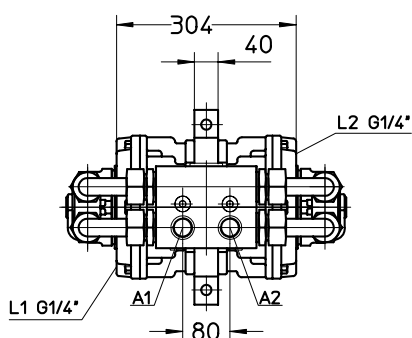
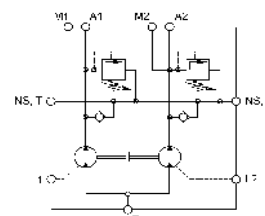

Connection

- E1 - E2 **G1 1/4"** Input, alternatively
- A1 - A2 **G1"** Output, section-flows
- L1 - L2 **G1/4"** Drain-ports, drain pressure max. 2 bar
- Important:** both ports have to be connected to the tank!
- T, NS **G3/8"** Tank- and low-pressure-feeding
- M1 - M2 **G3/8"** Measuringport for each sections

Radial piston flow divider MT-GM

MT-GM2... / ...-FEA

Weight: 150 kg

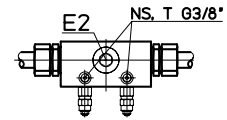
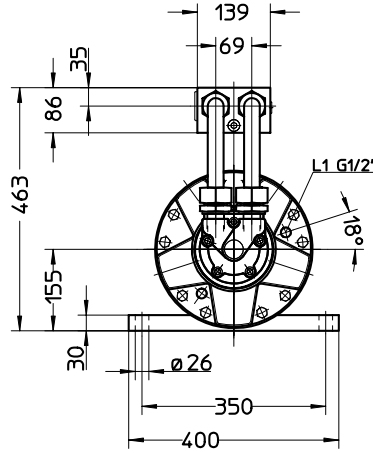
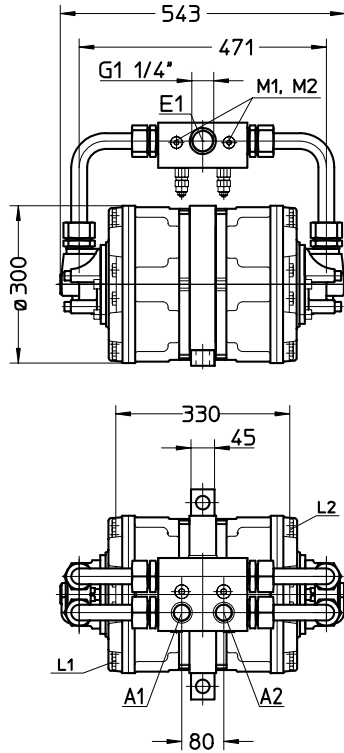

Circuit according DIN ISO 1219

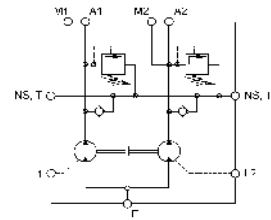

Connections

- E1, E2 **G1 1/4"** Input, alternatively
- A1, A2 **G1"** Output, section-flows
- L1, L2 **G1/2"** Drain-ports, drain pressure max. 2 bar
- Important:** both ports have to be connected to the tank!
- T, NS **G3/8"** Tank- and low-pressure-feeding
- M1, M2 **G3/8"** Measuringport for each sections

MT-GM3... / ...-FEA

Weight: 240 kg

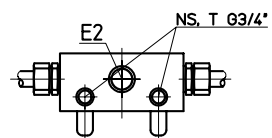
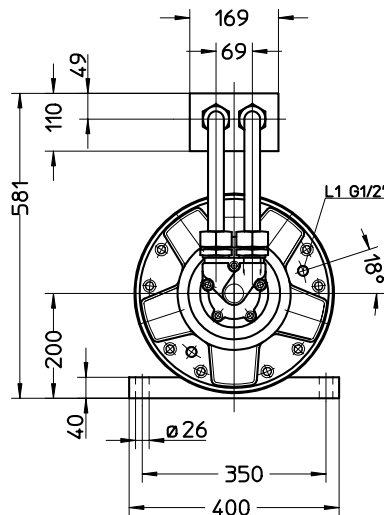
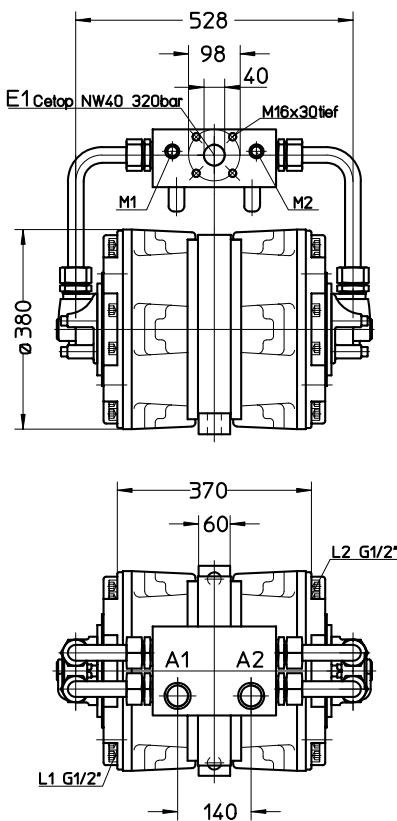

Circuit according DIN ISO 1219

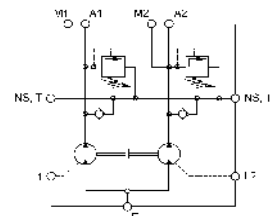

Connections

- E1, E2 **NW 40 / G1 1/4"** Input, alternatively
- A1, A2 **G1 1/4"** Output, section-flows
- L1, L2 **G1/2"** Drain-ports, drain pressure max. 2 bar
- Important:** both ports have to be connected to the tank!
- T, NS **G3/4"** Tank- and low-pressure-feeding
- M1, M2 **G1/2"** Measuringport for each sections

Radial piston flow divider MT-GM

MT-GM5... / ...FEA

Weight: 480 kg

Connections

| | | |
|---|-------------------|--|
| E1 - E2 | SAE 1 1/2" | Input, to be connected together |
| A1 - A2 | SAE 1 1/2" | Output, section-flows |
| L1 - L2 | G1/2" | Drain-ports, drain pressure max. 2 bar |
| Important: both ports have to be connected to the tank ! | | |
| T, NS | G1 1/2" | Tank- and low-pressure-feeding, to be connected together |
| M1, M2 | G1/4" | Measuringport |

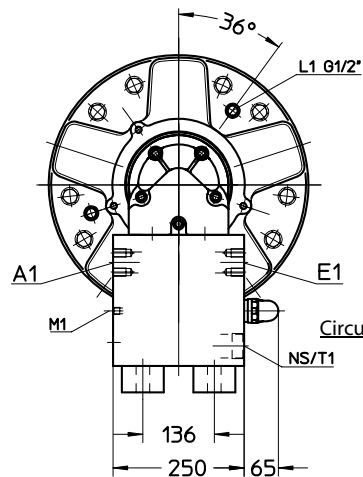
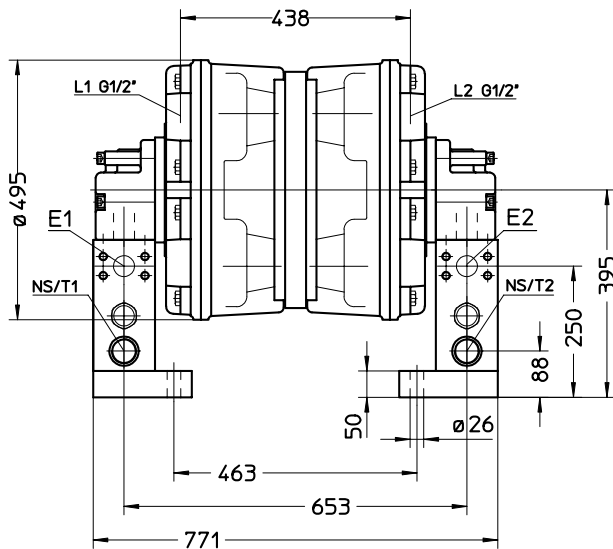

Circuit according DIN ISO 1219

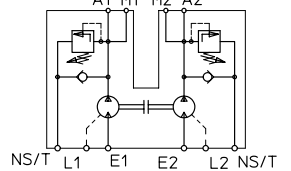

Connections

| | | |
|---|-------------------|--|
| E1 - E2 | SAE 1 1/2" | Input, to be connected together |
| A1 - A2 | SAE 1 1/2" | Output, section-flows |
| L1 - L2 | G1/2" | Drain-ports, drain pressure max. 2 bar |
| Important: both ports have to be connected to the tank ! | | |
| T, NS | G1 1/2" | Tank- and low-pressure-feeding, to be connected together |
| M1, M2 | G1/4" | Measuringport |

MT-GM6... / ...FEA

Weight: 725 kg

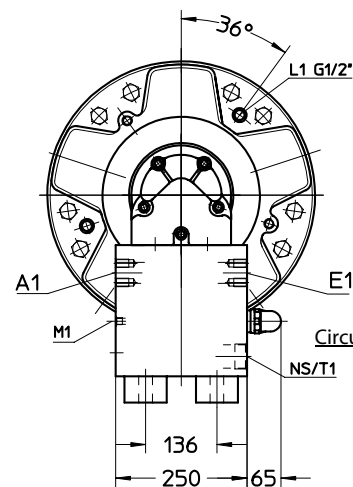
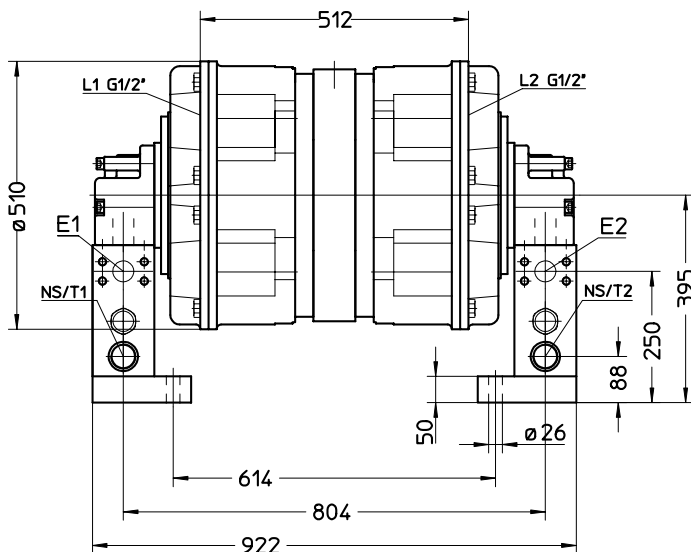

Circuit according DIN ISO 1219

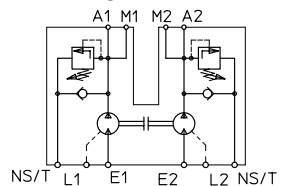

Radial piston flow divider MTL

Connections

A1 to A4 or B1 to B4 **G1/4"** Input, to be connected together
 B1 to B4 or A1 to A4 **G1/4"** Output, section-flows
 L **G3/4"** Drain-ports, drain pressure max. 10 bar

MTL../ 70-G

MTL../ 108-G

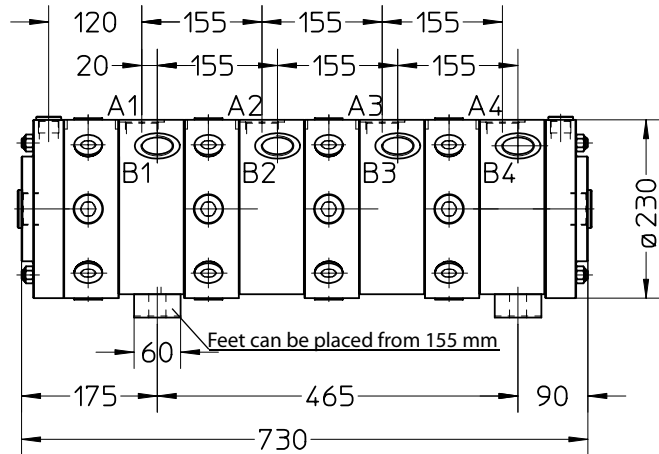
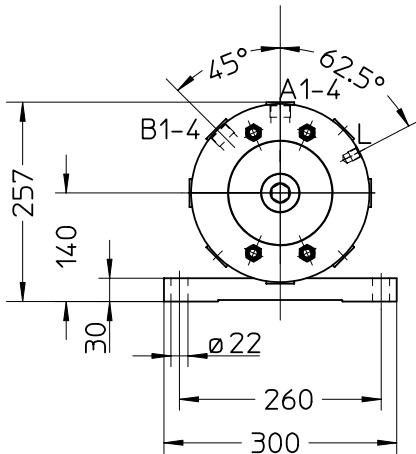

The drawing shows a 4-section flow-divider. Using more or less sections, you have to calculate the total length with a difference of 155 mm each section.

Connections

A1 to A4 or B1 to B4 **G1/4"** Input, to be connected together
 B1 to B4 or A1 to A4 **G1/4"** Output, section-flows
 L **G3/4"** Drain-ports, drain pressure max. 10 bar

MTL../ 170-G

MTL../ 270-G

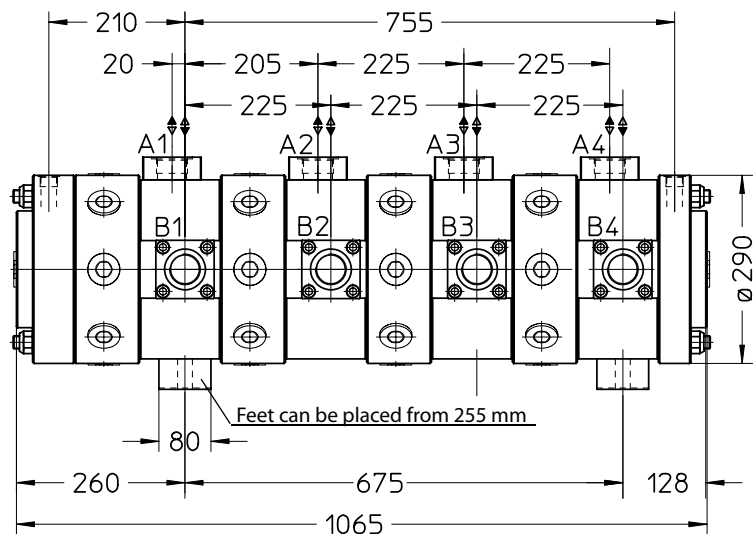
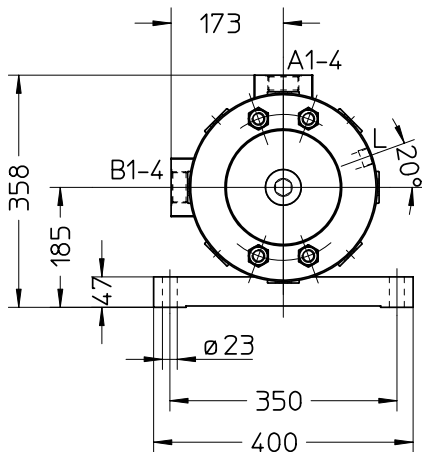

The drawing shows a 4-section flow-divider. Using more or less sections, you have to calculate the total length with a difference of 255 mm each section.

Radial piston flow divider MTL

Connections

| | | |
|----------|----------------|---|
| E | G1 1/2" | Input |
| A1 to A4 | G1 1/4" | Output, divided flows |
| L | G3/4" | Drain port, drain-pressure max. 10 bar |
| T, NS | G1 1/4" | Tank and low-pressure-feeding |
| M1 to M4 | G1/4" | Measuring port for each section |

MTL../ 70-EA2

MTL../ 108-EA2

circuit according DIN ISO 1219

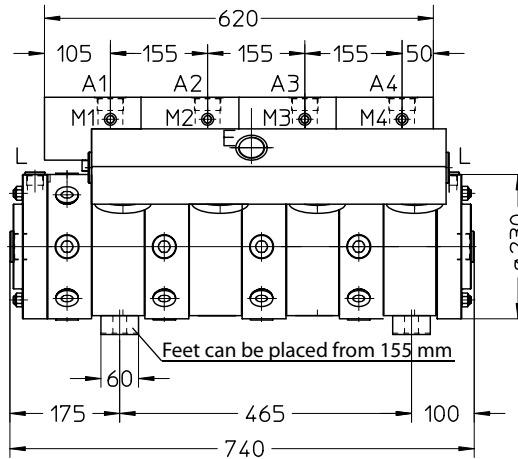
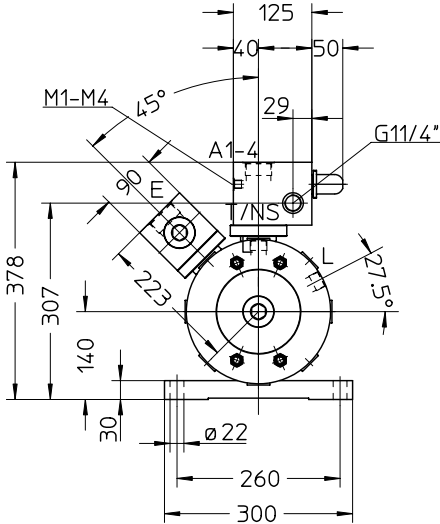
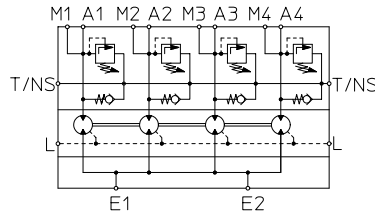

The drawing shows a 4-section flow-divider. Using more or less sections, you have to calculate the total length with a difference of 155 mm each section.

Weight: MTL../70-EA and MTL../108-EA 74 kg/section

Connections

| | | |
|----------|----------------|---|
| E | G2" | Input |
| A1 to A4 | G1 1/2" | Output, divided flows |
| L | G3/4" | Drain port, drain-pressure max. 10 bar |
| T, NS | G3/4" | Tank and low-pressure-feeding |
| M1 to M4 | G1/4" | Measuring port for each section |

MTL../ 170-EA

MTL../ 270-EA

circuit according DIN ISO 1219

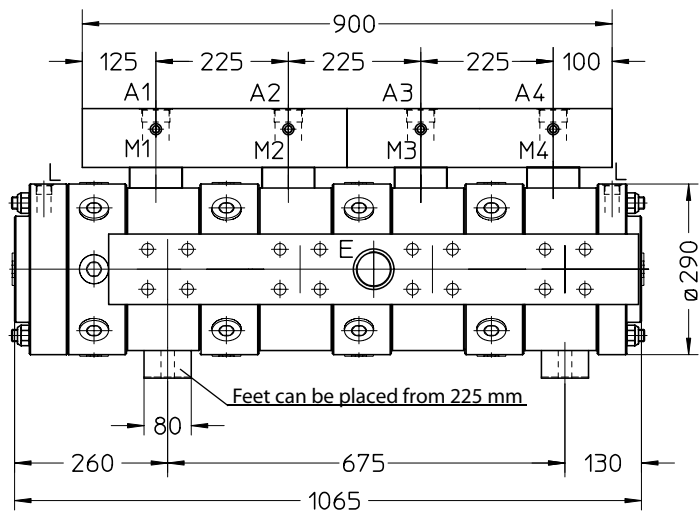
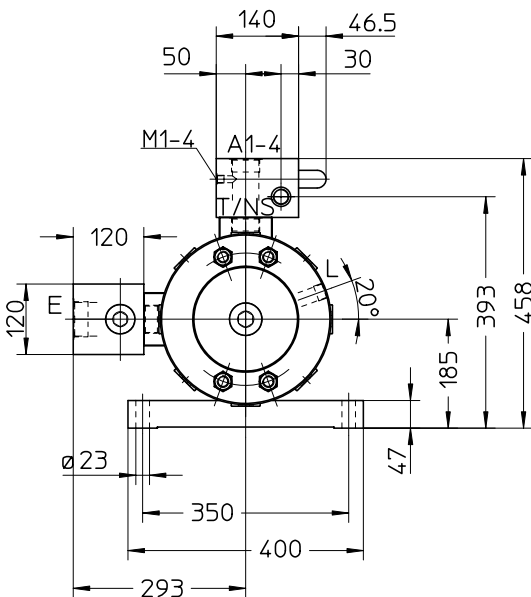
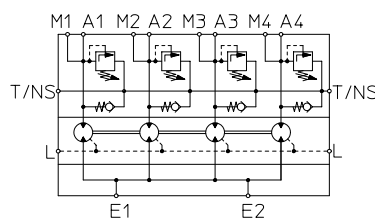

The drawing shows a 4-section flow-divider. Using more or less sections, you have to calculate the total length with a difference of 255 mm each section.

Weight: MTL../170-EA and MTL../270-EA 167 kg/section

Radial piston flow divider STL

| Type | Displacement per section (cm ³ /rev) | Flow per section | | Pressure | | Max. power per section (kW) |
|--------------------|---|-----------------------|-------------------------|---------------------|-----------------------|-----------------------------------|
| | | continuous (l/min) | intermittend (l/min) | continuous (bar) | intermittend (bar) | |
| STL...- 220 | 494,1 | 220 | 280 | 240 | 300 | 100 |
| STL...- 320 | 722,2 | 320 | 400 | 240 | 300 | 125 |

Complete drawings of the series STL-2-220 to STL-12-320 of different sizes are available upon request.

Order codes

Example: **STL-4-320-EA**

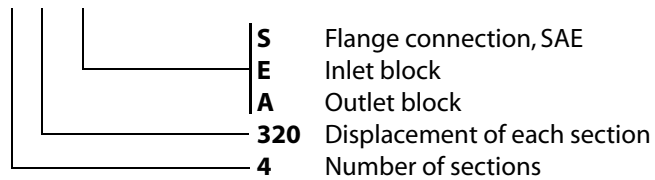

Radial piston flow divider STL

Connections

| | | |
|----------|---------------------------|---|
| E1 to E4 | SAE NW50, 6000 psi | Input |
| A1 to A4 | SAE NW50, 6000 psi | Output, divided flows |
| L | G1" | Drain port, drain-pressure max. 10 bar |

STL..- 220-S

STL..- 320-S

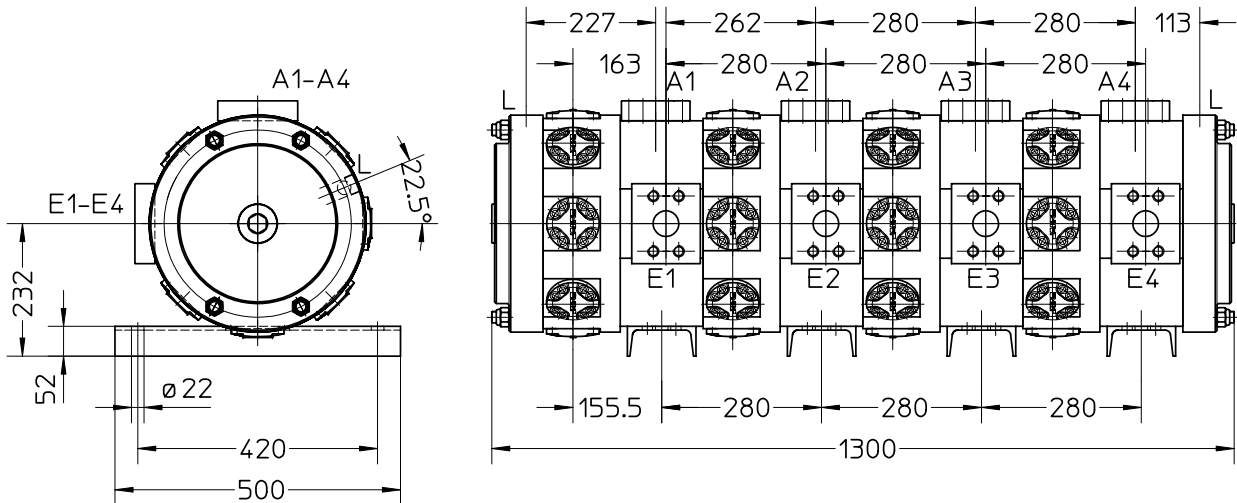

The drawing shows a 4-section flow-divider. Using more or less sections, you have to calculate the total length with a difference of 280 mm each section.

Weight: STL..-220-S and STL..-320-S 240 kg/section

Connections

| | | |
|----------|-----------------------------|---|
| E1 to E2 | SAE 2 1/2", 6000 psi | Input |
| A1 to A4 | SAE NW50, 6000 psi | Output, divided flows |
| L | G1" | Drain port, drain-pressure max. 10 bar |
| T, NS | SAE NW50, 3000 psi | Tank and low-pressure-feeding |
| M1 to M4 | G1/4" | Measuring port for each section |

circuit according DIN ISO 1219

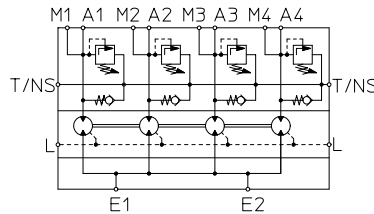

STL..- 220-EA

STL..- 320-EA

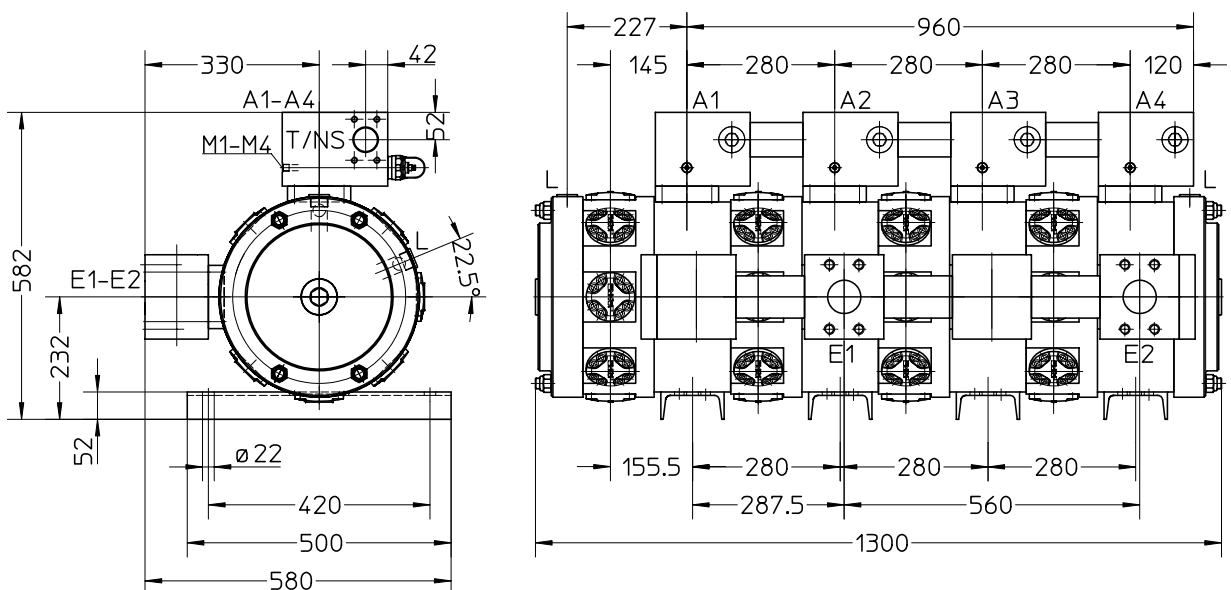

The drawing shows a 4-section flow-divider. Using more or less sections, you have to calculate the total length with a difference of 280 mm each section.

Weight: STL..-220-EA and STL..-320-EA 296 kg/section

Components for hydraulics and process technology

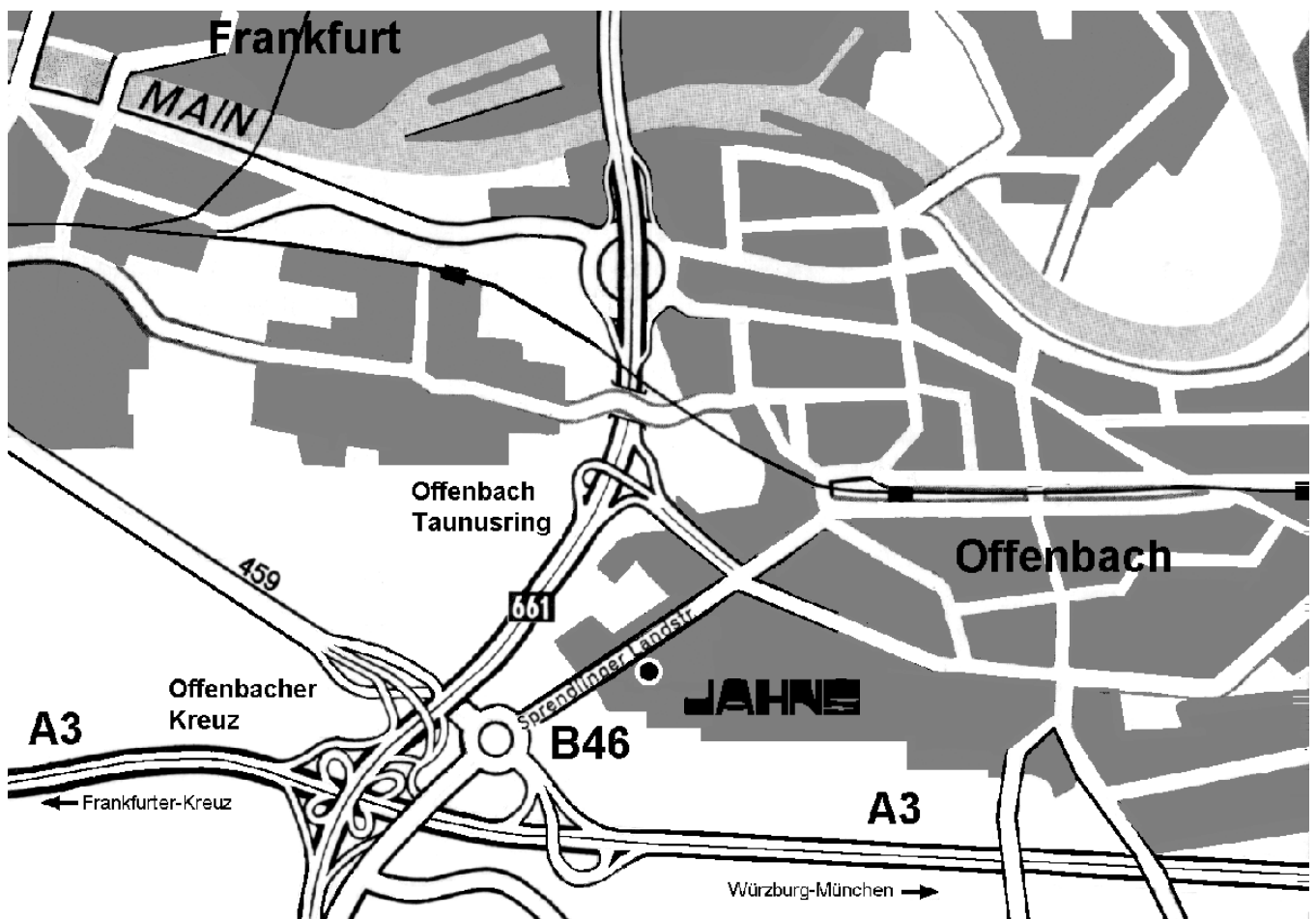

Jahns-Regulatoren GmbH

Postbox 10 09 52
D 63009 Offenbach
telephon +49/(0)69/84 84 77-0

home address
Sprendlinger Landstraße 150
D 63069 Offenbach
telefax +49/(0)69/84 84 77 25

<http://www.jahns-hydraulik.de>
info@jahns-hydraulik.de